

CITY OF LINCOLN PARK

Police Station Additions

**Advertisement, Instructions to Bidders, General Conditions of
Construction Contract, Contract, Specifications**

**BOARD OF TRUSTEES
HURON CHARTER TOWNSHIP**

Thomas E. Karnes - Mayor

City Clerk Kerry Kehrer

Carlos Salcido - Council President

Council Members

Michael Higgins

Lylian Ross

Maureen Tobin

Tracy Duprey

Larry Kelsey

TABLE OF CONTENTS

<u>PART I - BIDDING REQUIREMENTS</u>	<u>PAGE NO.</u>
Invitation to Bid.....	AB-1
Instructions to Bidders.....	IB-1-5
Special Instructions to Bidders.....	SIB-1-3
Bid Bond.....	BB-1-2
 <u>PART II - CONTRACT FORMS</u>	
Proposal EXHIBIT A	A-1
Itemized Pay Item Sheet.....	A-2-3
Agreement	AG-1-4
 <u>PART III - CONDITIONS OF THE CONTRACT</u>	
Article 1 — Definitions.....	GC-1-2
Article 2 — Preliminary Matters	GC-3
Article 3 — Contract Documents: Intent and Reuse	GC-4
Article 4 — Availability of Lands; Physical Conditions; Reference Points	GC-5
Article 5 — Bonds and Insurance	GC-6-9
Article 6 — Contractor's Responsibility.....	GC-10-15
Article 7 — Work by Others	GC-16
Article 8 — Owner's Responsibility.....	GC-17
Article 9 — Engineer's Status During Construction.....	GC-18-19
Article 10 — Changes in Work.....	GC-20
Article 11 — Change of Contract Price	GC-21-23
Article 12 — Change of Contract Time	GC-24
Article 13 — Warranty and Guarantee: Tests and Inspections; Correction,	GC-25-26
Removal or Acceptance of Work	
Article 14 — Payments to Contractor and Completion.....	GC-27-29
Article 15 — Suspension of Work and Termination	GC-30-31
Article 16 — Miscellaneous	GC-32
Article 17 — Construction Follow Up	GC-33
 <u>PART IV - SUPPLEMENTAL SPECIFICATIONS</u>	
Architectural Specifications – Specifications	

**INVITATION TO BID
CITY OF LINCOLN PARK
WAYNE COUNTY, MICHIGAN
Police Station Additions**

**City of Lincoln Park is accepting Bids for the
POLICE STATION ADDITIONS
In Lincoln Park, Wayne County, Michigan**

The proposed Bid is for the construction of two additions to the existing Lincoln Park Police Station at 1427 Cleophus Pkwy in the City of Lincoln Park. The project consists of two building additions of masonry construction as part of phase 1 for storage of required materials.

Bids will be received by:
City Clerk Kerry Kehrer

At the offices of:
City of Lincoln Park
1355 Southfiled Road
Lincoln Park, MI 48146

Until Wednesday January 11th, 2023 at 10:00 a.m. (local time)

Bids shall be publicly opened and read on:
Wednesday January 11th, 2023, at 10:00 a.m. (local time)
City of Lincoln Park
1355 Southfiled Road
Lincoln Park, MI 48146

Contract Documents will be available starting **Wednesday, December 14, 2022 after 1:00pm** and Contract Documents are available for review at the following link:

https://drive.google.com/drive/folders/1LBWMI2f6Uh_h9_Q1Wfnb0_THiw82t5oI?usp=sharing

Bidders must deposit, with their bid, surety in the form of a certified check, bank draft, or bid bond, in the sum of five percent (5%) of the amount of the proposal. The OWNER reserves the right to waive any information or to reject any and/or all bids. Bidders may not withdraw their bid within 60 days after the date of bid opened.

City of Lincoln Park
Kerry Kehrer, City Clerk

INSTRUCTIONS TO BIDDERS

Defined Terms

Disputes with respect to the definitions of any terms shall be resolved by Hennessey Engineers, Inc., (“ENGINEER”). The term “Successful Bidder” shall mean the qualified Bidder but not necessarily the lowest Bidder to whom Huron Township (“OWNER”) (on the basis of OWNER’s evaluation) makes an award.

Copies of Bidding Documents

1. Sets of the Bidding Documents in the number and for the deposit sum, if any, stated in the advertisement or invitation may be obtained from ENGINEER (unless another issuing officer is designated in the advertisement or Invitation to Bid).
2. Complete sets of Bidding Documents shall be used in preparing bids. Every Bidder shall ascertain that every set the Bidder obtains from the OWNER or ENGINEER is complete. Neither OWNER nor ENGINEER assumes any responsibility for errors or misinterpretations resulting from the use of incomplete sets of the Bidding Documents.
3. OWNER and ENGINEER, in making copies of Bidding Documents available on the above terms, do so only for the purpose of obtaining bids for the work and do not confer a license or grant for any other use of the Bidding Documents by the Bidder.

Qualifications of Bidders

To demonstrate qualifications to perform the work, each Bidder must be prepared to submit within five (5) days of OWNER’s or ENGINEER’s request, written evidence of any information deemed necessary by the ENGINEER for bid evaluation, including, but not limited to, financial data, previous experience, evidence of authority to conduct business in the jurisdiction where the project is located or covenant to obtain such qualification prior to award of the contract. Failure to submit any such data within the five (5) day period shall give the OWNER and the ENGINEER the right to finally reject the CONTRACTOR’s bid.

Examination of Contract Documents and Site

1. Before submitting a bid, each Bidder must (a) examine the Contract Documents thoroughly; (b) visit the site to familiarize itself with local conditions that may, in any way, affect cost, progress or performance of the work; (c) familiarize itself with federal, state and local laws, ordinances, rules and regulations that may, in any way, affect cost, progress or performance of the work; and (d) study and carefully correlate Bidder’s observations with the Contract Documents.
2. Request may be made for the identification of those reports of investigations and tests of subsurface and latent physical conditions on the site or otherwise affecting cost, progress or performance of the work, which have been relied upon by ENGINEER in preparing the Contract Documents. OWNER may make copies of such reports available to any Bidder requesting them. Before submitting its bid, each Bidder shall, at its own expense, prepare additional investigations and tests as the Bidder may deem necessary to prepare its bid for performance of the work. The OWNER and ENGINEER make no guarantee as to the accuracy or the completeness of the reports. Nor are they included in the Contract Documents.
3. On request, OWNER will provide each Bidder access to the site to conduct investigations and tests as each Bidder deems necessary for submission of his bid.
4. It is the responsibility of the CONTRACTOR to make whatever arrangements it deems necessary to obtain access to the property that is not included within the project, including,

- but not limited to, land necessary to obtain access to the project, land for storage of material and equipment, etc.
5. The submission of a bid will constitute an incontrovertible representation by the Bidder that it has complied with every requirement of this Article 4 and all other provisions of the Contract Documents and that the Contract Documents are sufficient in scope and detail to indicate and convey understanding of all terms and conditions for performance of the work.

Interpretations

All questions relating to the meaning or intent of the Contract Documents shall be submitted to the ENGINEER in writing. Replies, if any, may be issued if ENGINEER decides it to be in the interest of the project, by addenda mailed or delivered to all parties recorded by ENGINEER as having received the Bidding Documents. ENGINEER reserves the right not to answer questions received less than 10 days prior to the date for opening of bids. Only questions answered by formal written addenda will be binding. Oral and other interpretations or clarifications will be without legal effect.

Bid Security

1. Bid Security shall be made payable to OWNER in an amount of five percent (5%) of the Bidder's maximum bid price and in the form of a certified or bank check or a Bid Bond (on the attached form if a form is prescribed) issued by a Surety meeting the requirements of Article 5 of the General Conditions.
2. The bid security of the Successful Bidder will be retained until the Successful Bidder has executed the Agreement and furnished the required contract security, whereupon the bid security will be returned to the Successful Bidder. If the Successful Bidder fails to execute and deliver the Agreement and furnish the required contract security within 10 days of the Notice of Award. OWNER may withdraw and/or void the Notice of Award and the bid security of the Successful Bidder will be forfeited. The bid security of all other Bidders whom the OWNER believes to have a reasonable chance of receiving the award may be retained by OWNER until the earlier of the fourteenth day after the "effective date of the Agreement" (which term is defined in the General Conditions) or the ninety-first day after the date of the bid opening. The bid security of all other Bidders will be returned within 14 days of the date of the bid opening.

Contract Time

The number of days within which, or the date by which, the work is to be completed (the Contract Time) is set forth in the Bid Form and shall be included in the Agreement.

Liquidated Damages

Provisions for liquidated damages, if any, are set forth in the Agreement.

Substitute Material and Equipment

The Notice of Award shall be based on the materials and equipment described in the Contract Documents without consideration of possible substitute of "or equal" items. Whenever it is indicated in the Contract Documents that a substitute of "or equal" items of material or equipment may be furnished or used by CONTRACTOR if acceptable to ENGINEER, application for such acceptance will not be considered by ENGINEER until after the "effective date of the Agreement." The procedure for submittal of any such application by CONTRACTOR and consideration by ENGINEER is set forth in Article 6 of the General Conditions.

Subcontractors

If the ENGINEER requires the identity of certain SUBCONTRACTORS and other persons and organizations to be submitted to OWNER in advance of the Notice of Award, the Successful Bidder,

and any other Bidder so requested shall, within five (5) days after the day of the bid opening, submit to OWNER a list of all SUBCONTRACTORS and other persons and organizations (including those who are to furnish the principal items of material and equipment) proposed for those portions of the work as to which such identification is so required.

Such a list shall be accompanied by an Experience Statement with pertinent information as to similar projects and other evidence of qualifications for each such SUBCONTRACTOR, persons and organization. If OWNER or ENGINEER has any objection to any proposed SUBCONTRACTOR, other person or organization, either may, before giving the Notice of Award, request the Successful Bidder to submit an acceptable substitute without an increase in bid price. If the apparent Successful Bidder declines to make any such substitution, the Contract shall not be awarded to the Successful Bidder. The Successful Bidder's unwillingness to make such substitution will not constitute grounds for sacrificing its bid security. After giving the Notice of Award, if the OWNER or ENGINEER, after due investigation, has reasonable objection to any SUBCONTRACTOR, other person or organization, either may request the Successful Bidder to provide an acceptable substitute without an increase in the contract price. In such a case, neither the OWNER nor the ENGINEER shall be liable for any damages or remedies of either the CONTRACTOR or the SUBCONTRACTOR and other person or organization, of this provision of the Contract prior to the parties being contractually bound.

Bid Form

1. The Bid Form attached hereto; additional copies may be obtained from ENGINEER after payment of the required charge.
2. Bid Forms must be completed in ink or by typewriter but not pencil. The bid price of each item on the form must be stated in words and numerals. In the event of an inconsistency, the words will take precedence. However, if, in the opinion of the ENGINEER, the inconsistency is substantial, then the ENGINEER shall have the authority to consider the CONTRACTOR's bid non-uniform, and void and award the contract to another Bidder without the ENGINEER or OWNER incurring any liability to the rejected Bidder.
3. Bids by corporation must be executed in the corporate name by the president or a vice president (or other corporate officer accompanied by evidence of authority to sign) and the corporate office must be affixed and attested by the secretary or an assistant secretary. The corporate address and state of incorporation shall be shown below the signature.
4. Bids by partnerships must be executed in the partnership name and signed by a partner whose title must appear under the signature. The address of the partnership must be included below the signature of the partner.
5. All names must be type or printed below the signature.
6. The bid shall contain an acknowledgment of receipt of all addenda prepared by the ENGINEER (the numbers of which shall be filled in on the Bid Form).
7. The address to which communications regarding the bid are to be directed must be included.

Submission of Bids

Bids shall be submitted at the time and place indicated in the Invitation to Bid and shall be included in an opaque sealed envelope shall be enclosed in a separate envelope with the notation "BID ENCLOSED" and "**Lincoln Park Animal Shelter**" on the face thereof.

Modification and Withdrawal of Bids

1. Bids may be modified or withdrawn by an appropriate document duly executed (in the manner that a bid must be executed) and delivered to the place where bids are to be submitted at any time prior to the opening of bids.
2. If, within 24 hours after bids are opened, any Bidder files a duly-signed written notice with OWNER, and promptly thereafter demonstrates to the reasonable satisfaction of OWNER

that there was a material and substantial mistake in the preparation of his bid, that Bidder may withdraw his bid and the bid security will be returned. Thereafter, that Bidder will be disqualified from further bidding on the work.

Opening of Bids

Bids will be opened publicly; they will be read aloud and an abstract of the amounts of the base bids and major alternates, if any, will be made available after the opening of bids.

Bids to Remain Open

All bids shall remain open for 90 days after the date of the bid opening. However, the OWNER may, in its sole discretion, release any bid and return the bid security prior to that date.

Award of Contract

1. OWNER shall have the right to reject any bid, to waive any and all informalities, to negotiate contract terms with the Successful Bidder, and to disregard all non-conforming, non-responsive or conditional bids. Discrepancies between the indicated sum of any column of figures and the correct sum thereof shall be resolved in favor of the correct sum. However, if, in the opinion of the ENGINEER, the conflict is substantial, then the OWNER shall have the right to consider the CONTRACTOR's bid non-uniform, void the bid and award the Contract to another Bidder. The ENGINEER or OWNER shall incur no liability to the rejected Bidder.
2. In evaluating bids, the OWNER and ENGINEER shall consider the qualifications of the Bidders, whether or not the bids comply with the prescribed requirements, alternates and unit prices, if requested in the Bid Forms, and any other consideration the OWNER or ENGINEER deems pertinent. OWNER may accept alternates in any order or combination.
3. The OWNER and ENGINEER may consider the qualifications and experience of SUBCONTRACTORS and other persons and organizations (including those who are to furnish the principal items or material or equipment) proposed for those portions of the work as to which the identity of SUBCONTRACTORS and other persons or organizations must be submitted as provided in Section 10 of Instructions to Bidders. Operating costs, maintenance considerations, performance data and guarantee of materials and equipment also may be considered by OWNER and ENGINEER.
4. The OWNER and ENGINEER may conduct such investigations as they deem necessary to assist in the evaluations of any bid and to establish the responsibility, qualifications and financial ability of the Bidders, proposed SUBCONTRACTORS and other persons and organizations to do the work in accordance with the Contract Documents.
5. The OWNER shall have the right to reject the bid of any Bidder who does not pass any such evaluation to OWNER's and ENGINEER's satisfaction.
6. If the contract is to be awarded, it will be awarded to the Bidder whose evaluation by OWNER confirms to OWNER that the award will be in the best interests of the project.
7. If the contract is to be awarded, OWNER will give the Successful Bidder a Notice of Award within 90 days after the date of the bid opening.

Performance and Other Bonds

Article 5 of the General Conditions sets forth OWNER's requirements as to performance and other bonds. When the Successful Bidder delivers the executed Agreement to OWNER, it shall be accompanied by the required contract security.

Signing of the Agreement

When OWNER gives a Notice of Award to the Successful Bidder, it will be accompanied by at least three (3) unsigned counterparts of the Agreement and all other Contract Documents. Within 10 days

thereafter, CONTRACTOR shall sign and deliver all signed counterparts of the Agreement to the OWNER with all other Contract Documents attached. Within 15 days thereafter, OWNER will deliver all fully signed counterparts to CONTRACTOR. ENGINEER will identify those portions of the Contract Documents not fully signed by OWNER and CONTRACTOR and such identification shall be binding on all parties.

Special Legal Requirements

1. Statement required by federal, state or local law or regulation or funding agency or appropriate reference thereto;
2. Bid pricing requirements on base bid alternatives, cash allowances (see Article 11 of General Conditions), unit prices and acceptable combinations;
3. Prep-purchasing by OWNER and subsequent assignment of purchase order to CONTRACTOR;
4. OWNER's special tax exemption;
5. Detailed description of work cross-reference to General Requirements; and
6. Division of work into separate parts with cross-reference to General Requirements.

These instructions to bidders and incorporated in the contract and made a part thereof.

SPECIAL INSTRUCTIONS TO BIDDERS

It is the intent of the OWNER that the CONTRACTOR shall complete all work as shown on the contract drawings. However, the OWNER reserves the right to delete locations shown on the contract drawings and to add additional locations within Huron Township.

Bid Prices

Bid prices shall remain firm for 90 days and shall include all costs associated with materials, equipment, tools, labor, signing, incidentals and transportation necessary to fully complete the project in compliance with the Specifications.

ENGINEER

1. The ENGINEER, Hennessey Engineers, Inc., shall have general supervisory authority to stop the work whenever such stoppage may be necessary to ensure the proper execution of the contract. The ENGINEER also shall have authority to reject any work or materials, which do not conform to the contract, to resolve any questions regarding the Contract Documents, and to provide any interpretation of the Contract Documents.
2. The CONTRACTOR shall immediately report to the Engineer any questionable or obvious error or omission in the Contract Documents and shall not proceed with the work until the ENGINEER has addressed the error or omission.
3. Questions regarding the Specifications may be directed to **Ray Parker** at (734) 759-1600.
4. The ENGINEER shall have the right to inspect any materials to be used by the CONTRACTOR in performing its work with respect to this contract.
5. The OWNER and ENGINEER do not assume any liability for the availability of materials, equipment or components required under this contract.
6. Materials, equipment, components or completed work not in compliance with the Contract Documents may be rejected by the ENGINEER or designated representative, and shall be replaced by the CONTRACTOR at no cost to the OWNER or ENGINEER.

Responsibility of CONTRACTOR

1. The CONTRACTOR shall be responsible for its work. The CONTRACTOR assumes all risk of damage to its work under the contract and agrees to defend and indemnify the OWNER and ENGINEER against any and all claims arising out of, or related to, its work under the contract.
2. The CONTRACTOR shall be held responsible for the satisfactory and complete execution of its work under the contract. The CONTRACTOR shall provide, without extra charge, all incidental items required as a part of its work under the contract, even if not particularly specified or indicated.
3. All work performed by the CONTRACTOR shall comply with any and all industry standards and federal, state and local codes, statutes and ordinances which shall be considered as included as part of the Contract Documents.
4. Any reference in these documents to Standard Specifications shall mean the latest revision of those Specifications and shall become a part of the Contract Documents. Any part of the work not completely detailed in these documents, or referenced in a Standard Specification, shall be governed by the latest edition of the proper industry document.
5. The CONTRACTOR shall supervise its work under the contract and shall have a competent person on site at all times when work is performed.
6. The CONTRACTOR shall daily remove all rubbish and accumulated materials resulting from its work under this contract.

7. The CONTRACTOR shall comply with all applicable OSHA and MIOSHA regulations.

Site Inspection

The CONTRACTOR is required to investigate and become familiar with all conditions relating to the work to be performed by it under this contract; shall verify all measurements and materials required under this contract; and shall be responsible for correctness of same. The CONTRACTOR shall not be entitled to any extra charges or compensation for any errors, omissions or miscalculations on the part of the CONTRACTOR, or because of the failure on the part of the CONTRACTOR to investigate or inspect the site.

Site Security

The CONTRACTOR shall be solely responsible for job site security of his materials and tools. The OWNER and ENGINEER shall not be liable to the CONTRACTOR for any loss or damage to the CONTRACTOR's materials and tools.

Site Access

The OWNER will provide fair and reasonable access to the job site within the working schedule of both parties.

Protection of Work, Property and Public

1. The CONTRACTOR shall maintain adequate protection of its work from damage and shall protect all public and private abutting property from injury or loss arising in connection with this contract. The CONTRACTOR shall provide and maintain all barricades, lights, fences, watch persons or other facilities necessary to protect all persons from danger or hazardous conditions resulting from its work under this contract.
2. The CONTRACTOR shall confine its equipment and operations to those areas of the work site necessary for the completion of its work, or as authorized by the ENGINEER. The CONTRACTOR shall protect and preserve from damage any facilities, utilities or features including trees, shrubs and turf, which are not required to be disturbed by the requirements of the work.
3. The CONTRACTOR shall supply and maintain all necessary lights, signs and barricades for the protection of the work and of the public. Traffic control devices used by the CONTRACTOR shall conform to the Michigan Manual of Uniform Traffic Control Devices (abstracted in a MDOT publication, "Construction Signing").
4. All protection and control devices within the "area of construction" shall be considered as incidental to the performance of the work by the CONTRACTOR and, therefore, the CONTRACTOR shall not be entitled to any extra payment of compensation for providing same. For purposes of this contract, the "area of construction" is defined as any city block in which the work of the CONTRACTOR may affect the safe travel of the public.

Construction Schedule and Coordination

1. Time is of the essence with respect to the work to be performed by the Contractor. Failure on the part of the CONTRACTOR to complete the work within the stated time it has set forth in the contract and agreed to herein, the CONTRACTOR shall be liable to the OWNER for any damages incurred by the OWNER as a result of such delay.
2. The CONTRACTOR shall coordinate with all other CONTRACTORS who may be working on the site in order to allow for the orderly progress of work being done on the site.
3. The CONTRACTOR shall supply the ENGINEER with an agreed upon Construction Schedule before commencing any work under this contract. The Construction Schedule shall detail beginning and completion dates for each major component of the project.

4. Construction delays resulting from tardiness on the part of the CONTRACTOR will be reviewed by the ENGINEER in the event of any request for extension by the CONTRACTOR.
5. The CONTRACTOR shall schedule all work to accommodate the City's schedule. In the event CONTRACTOR's schedule falls on weekends, nights or overtime work is required, no additional compensation will be allowed. All work shall be part of this Contract without regard to when it is done.
6. Note that this is a project requiring planning, scheduling and cooperation on the part of all parties concerned.

Contract Period

Bidders are advised that the contract will be for 90 days.

Minimum Contract Quantity

The minimum amount of work which will be performed under this contract will be as listed in the Itemized Bid Tabulation Sheets.

BID BOND

KNOW ALL MEN BY THESE PRESENTS, that we, the undersigned, _____

_____ as Principal, and

_____ as Surety, are

hereby held and firmly bound unto _____

as owner in the penal sum of _____

for payment of which, well and truly to be made, we hereby jointly and severally bind ourselves, our heirs, executors, administrators, successors and assigns.

Signed this _____ day of _____ 20__.

The Condition of the above obligation is such that whereas the Principal has submitted to

_____ a certain Bid, attached hereto and hereby made a part thereof to enter into a contract in writing for the:

Lincoln Park Police Station Additions

NOW, THEREFORE,

1. If said Bid shall be rejected, or in the alternate,
2. If said Bid shall be accepted and the Principal shall execute and deliver a contract in the Form of Contract attached hereto (properly completed in accordance with said Bid) and shall furnish bonds for his faithful performance of said contract, and for the payment of all persons performing labor or furnishing materials in connecting therewith, and shall, in all other respects, perform the agreement created by the acceptance of said Bid,

then this obligation shall be void, otherwise the same shall remain in force and effect; it being expressly understood and agreed that the liability of the Surety for any and all claims hereunder shall, in no event, exceed the penal amount of this obligation as herein stated.

The surety, for value received, hereby stipulates and agrees that the obligations of said Surety and its bond shall be in no way impaired or directed by any extension of the time within which the OWNER may accept such Bid; and said Surety does hereby waive notice of any such extension.

IT WITNESS WHEREOF, the Principal and the Surety have hereunto set their hands and seals, and such of them as are corporations have caused their corporate seals to be hereto affixed and these presents to be signed by their property officers, the day and year first set forth above.

(L.S.)

Principal

Surety

By: _____

IMPORTANT: Surety companies executing bonds must appear of the Treasury Department's most current list (Circular 570, as amended) and be authorized to transact business in the state where the project is located.

EXHIBIT A: PROPOSAL
For
Lincoln Park Police Station Additions

City of Lincoln Park, Michigan
Bids will be Due on:
Wednesday, 11-January-2023 until 10:00 a.m.

Bids will be opened on:
Wednesday, 11-January-2023 at 10:00 a.m.

TO: City of Lincoln Park
1355 Southfield Road
Lincoln Park, MI 48146

Gentlemen: The undersigned has examined the plans, specifications and locations of the above-described work and is fully informed as to the nature of the work and conditions relating to its performance and understands the quantities shown on the attached Itemized Bid Sheet(s) are approximate only and are subject to either increases or decreases unless specifically mentioned otherwise in this Contract; the undersigned fully understands all the Contract Documents including, but not limited to, Article 5 (Bonds and Insurance) and Article 17 (Construction Follow Up) of the General Conditions.

The undersigned hereby proposes to furnish all necessary machinery, tools, equipment, and other means of construction to do all the work, furnish all materials, except as herein specified, and to complete the work in strict conformity with the requirements of the Proposal and Specifications, all at unit prices set forth in the Itemized Bid Sheet(s).

The undersigned further agrees, if awarded the contract, to deliver executed contract and bonds and furnish evidence of insurance within 10 days after the date of award.

The undersigned encloses a certified or cashier's check or bid bond in the amount of five percent (5%) of the bid payable to the order of Huron Township within 10 days after being notified of contract awarded.

Signed: _____ Address : _____

Firm Name: _____

Telephone: _____ Fax: _____

All erasures or alterations must be initialed by the bidder.

Lincoln Park Police Station Additions Bid Tab

AGREEMENT

THIS AGREEMENT is dated as of the _____ day of _____
in the year 20____, by and between Huron Township hereinafter called OWNER, and

_____,
hereinafter called CONTRACTOR, whereas OWNER and CONTRACTOR, in consideration of the mutual covenants hereinafter set forth, agree as follows:

Article 1. **WORK**

CONTRACTOR shall complete all work as specified or indicated in the Contract Documents. The work is generally described as follows:

Lincoln Park Police Station Additions

Article 2. **ENGINEER**

The proposal has been completed by Hennessey Engineers, Inc., 13500 Reek Road, Southgate, Michigan 48195, which is hereinafter called ENGINEER, which will have the right and authority assigned to ENGINEER in the Contract Documents in connection with completion of the Work in accordance with the Contract Documents.

Article 3. **CONTRACT TIME**

3.1 The Work shall be substantially completed as provided in Article 2 of the General Conditions, and completed and ready for final payment in accordance with Article 12 of the General Conditions.

The work shall be completed and ready for final payment BY June 1, 2023, after the written notification to proceed.

3.2 **Liquidated Damages.** OWNER and CONTRACTOR recognize that time is of the essence of this Agreement and that OWNER will suffer financial loss if the work is not substantially completed within the time specified in paragraph 3.1 above, plus any extensions thereof allowed in accordance Article 12 of the General Conditions. They also recognize the delays, expense and difficulties involved in presiding in a legal or arbitration proceeding and the actual loss suffered by OWNER if the work is not substantially completed on time. Accordingly, instead of requiring any such proof, OWNER and CONTRACTOR agree that as liquidated damages for delay (but not as a penalty) CONTRACTOR shall pay OWNER, City of Lincoln Park, \$500 for each day that expires after the time specified in paragraph 3.1 for completion until the work is completed.

Article 4. **CONTRACT PRICE**

OWNER shall pay CONTRACTOR for performance of the work in accordance with the Contract Documents in current funds as shown in Exhibit A: Proposal.

Article 5. **PAYMENT PROCEDURES**

CONTRACTOR shall submit Applications for Payment in accordance with Article 14 of the General Conditions. Applications for Payment will be processed by ENGINEER as provided in the General Conditions. CONTRACTOR is to use AIA Document G-702 for all Applications of Payment.

5.1 **Progress Payments.** OWNER shall make progress payments on account of the Contract Price on the basis of CONTRACTOR'S Applications for Payment as recommended by ENGINEER about 35 days after submittal of pay request by CONTRACTOR. Progress

payments will be on the basis of the progress of the work, the amount of which will be decided by the ENGINEER. Progress payments will be made in accordance with State Act 524.

- 5.2 Final Payment. Upon final completion and acceptance of the Work in accordance with Article 14 of the General Conditions, OWNER shall pay the remainder of the Contract Price as recommended by ENGINEER as provided in said Article.

Article 6. CONTRACTOR'S REPRESENTATIONS

In order to induce OWNER to enter into this Agreement, CONTRACTOR makes the following representations:

- 6.1 Whenever anywhere in these Contract Documents insurance is required, the name of the OWNER.
- 6.2 CONTRACTOR has fully and completely familiarized himself with the nature and extent of the Contract Documents, work, locality and with all local conditions and federal, state and local laws, ordinances, rules and regulations that, in any manner, may affect cost, progress or performance of the work.
- 6.3 CONTRACTOR has studied carefully all reports of investigation and tests of subsurface and latent physical conditions at the site or otherwise affecting cost, progress or performance of the work which were relied upon by ENGINEER in the preparation of the drawings and specifications and which have been identified in the Supplementary Conditions.
- 6.4 CONTRACTOR has fully and completely made or caused to be made at CONTRACTOR'S expense, examinations, investigations, tests and studies of data, in addition to those referred to in paragraph 6.3 of the Agreement, including, but not limited to, subsurface conditions, soil and underground strength conditions, whether latent or not, and any underground utility structures or obstacles and any other data that may possibly be deemed pertinent to the performance of the work at the Contract Price, within the Contract Time and in accordance with the other terms and conditions of the Contract Documents, and any additional examinations, investigations, tests, reports or similar data as will be required by CONTRACTOR's agent at CONTRACTOR's expense. Such work should be considered incidental to the Contract Price.
- 6.5 CONTRACTOR has correlated the results of all such observations, examinations, investigations, tests, reports and data with the terms and conditions of the Contract Documents.
- 6.6 CONTRACTOR has given the ENGINEER written notice of all conflicts, errors, discrepancies that he has discovered in the Contract Documents and the written resolution thereof by the ENGINEER is acceptable to the CONTRACTOR.
- 6.7 The CONTRACTOR accepts all risk directly or indirectly connected with the performance of the Contract.
- 6.8 The CONTRACTOR warrants that he has not been influenced by an oral statement or promise of the OWNER or the ENGINEER, but only by the Contract Documents.

Article 7. CONTRACT DOCUMENTS

- 7.1 This Agreement (pages 1 through 5 inclusive)
- 7.2 Exhibit A: Proposal and Itemized Bid Sheet(s)
- 7.3 All bonds identified as Exhibit B: Performance Bond, Exhibit C: Payment Bond, and Exhibit D: Maintenance and Guarantee Bond
- 7.4 Notice of Award
- 7.5 General Conditions
- 7.6 Instructions to Bidders
- 7.7 Special Provisions bearing the title:

LINCOLN PARK POLICE STATION ADDITIONS

and consisting of pages, as listed in the Table of Contents thereof.

- 7.8 Drawings numbered CVR, A-1 THRU A-3 inclusive each bearing the following general title.

LINCOLN PARK POLICE STATION ADDITIONS

- 7.9 Addenda Numbers ____ to ____ inclusive
- 7.10 CONTRACTOR's Bid (pages ____ to ____ inclusive) marked Exhibit ____ (attach bid form only in special circumstances)
- 7.11 Documentation submitted by CONTRACTOR prior to Notice of Award (pages ____ to ____ inclusive)
- 7.12 Any modification, including Change Orders, duly delivered after execution of Agreement:

There are no Contract Documents other than those listed above in Article 7 of this Agreement. The Contract Documents may only be altered, amended or repealed by a Modification (as defined in Section 1 of the General Conditions)

Article 8. MISCELLANEOUS

- 8.1 Terms used in this Agreement, which are defined in Article 1 of the General Conditions, shall have the meanings indicated in the General Conditions.
- 8.2 No assignment by the CONTRACTOR hereto of any rights under or interest in the Contract Documents will be binding on the OWNER hereto without the written consent of the party sought to be bound; and, specifically, any not be assigned without such consent (except to the extent that the effect of this restriction may be limited by law); and, unless specifically stated to the contrary in any written consent to an agreement, no assignment will release or discharge the CONTRACTOR from any duty or responsibility under the Contract Documents.
- 8.3 OWNER and CONTRACTOR each binds himself, his partners, successors, assigns and legal representatives to the other party hereto, his partners, successors, assigns and legal representatives in respect to all covenants, agreements and obligations contained in the Contract Documents.

Article 9. RESOLVING CONFLICTS

In resolving conflicts, errors and discrepancies, the documents shall be given precedence in the following order: Agreement, Modification, Addenda, Supplementary Conditions, Instructions to Bidders, General Conditions, Special Provisions, Supplemental Specifications, Project Technical Specifications and Standard Notes. Figure dimensions on Drawings shall govern over scale dimensions, and detailed Drawings shall govern over general Drawings.

IN WITNESS WHEREOF, the parties hereto have signed this Agreement in triplicate. One counterpart each has been delivered to OWNER, CONTRACTOR and ENGINEER. All parties of the Contract Documents have been signed or identified by OWNER and CONTRACTOR or by ENGINEER on their behalf.

This Agreement will be effective on _____ 20__.

OWNER _____

By: _____
(CORPORATE SEAL)

Attest _____

Attest: _____

Address for giving notices: _____

Telephone: _____ Fax: _____

CONTRACTOR _____

By: _____
(CORPORATE SEAL)

Attest _____

Attest: _____

Address for giving notices: _____

Telephone: _____ Fax: _____

CONTRACTOR'S AFFIDAVIT
Current Estimate

STATE OF _____ COUNTY OF _____,

The undersigned, _____,

Hereinafter called the CONTRACTOR, hereby represents that on _____,

_____ he/it was awarded a Contract by

_____ hereinafter called the OWNER, to _____

in accordance with the terms of Contract No. 73137; and the undersigned further represent that all progress payments heretofore received from the OWNER on account of the work have been applied by the CONTRACTOR to discharge in full all of the CONTRACTOR's obligations incurred in connection with the work by all prior estimates.

This affidavit is freely and voluntarily given with full knowledge of the facts, on this ____ day of _____, A.D., 20__.

CONTRACTOR

By: _____

Title

Subscribed and sworn to before me this ____ day of _____, in the year of our Lord, 20__.

Notary Public
My Commission expires on: _____

CONTRACTOR'S AFFIDAVIT
Final Estimate

STATE OF _____ COUNTY OF _____,

The undersigned, _____,

Hereinafter called the CONTRACTOR, hereby represents that on _____,

_____ he/it was awarded a Contract by

hereinafter called the OWNER, to _____

in accordance with the terms of Contract No. 73137; and the undersigned further represent that subject work has now been accomplished, and the said Contract has now been completed.

The undersigned hereby warrants and certifies that all of his (its) indebtedness arising by reason of the said Contract has been fully paid or satisfactorily secured; and that all claims from SUBCONTRACTORS and others for labor and material used in accomplishing said project, as well as all other claims arising from the performance of said Contract, have been fully paid or satisfactorily settled. The undersigned further agrees that, if any such claim should hereinafter arise, he (it) shall assume responsibility for the same immediately upon request to do so by the OWNER.

The undersigned, for a valuable consideration, the receipt of which is hereby acknowledged, does further hereby waive, release and relinquish any and all claims or right of lien which the undersigned has or may hereafter acquire upon the subject premises for labor and material used in accomplishing said project owned by the OWNER.

This affidavit is freely and voluntarily given with full knowledge of the facts, on this ____ day of _____, A.D., 20__.

CONTRACTOR

By: _____

Title

Subscribed and sworn to before me this ____ day of _____, in the year of our Lord, 20__.

Notary Public
My Commission expires on: _____

CONTRACTOR'S AFFIDAVIT
Construction Materials

STATE OF _____ COUNTY OF _____,

The undersigned, _____,

Hereinafter called the CONTRACTOR, hereby represents that on _____,

_____ he/it was awarded a Contract by

_____ hereinafter called the OWNER, to _____

in accordance with the terms and conditions of the Contract No. 73137; and the undersigned further represent that all materials used and installed on the project were received by a certified manufacturer's supplier and was installed per all applicable manufacturer's recommendations.

This affidavit is freely and voluntarily given with full knowledge of the facts, on this ____ day of _____, A.D., 20__.

CONTRACTOR

By: _____

Title

Subscribed and sworn to before me this ____ day of _____, in the year of our Lord, 20____.

Notary Public

My Commission expires on: _____

CONTRACTOR'S AFFIDAVIT
Site Visit and Understanding

STATE OF _____ COUNTY OF _____,

The undersigned, _____,

Hereinafter called the CONTRACTOR, hereby represents that on _____,

in accordance with the terms and conditions of Contract; and the undersigned further acknowledges that he has visited the site and has an understanding of the proposed project and proposed site.

This affidavit is freely and voluntarily given with full knowledge of the facts, on this

_____ day of _____ A.D., 20_____.

CONTRACTOR

By: _____

Title

Subscribed and sworn to before me this ____ day of _____, in the year of our Lord, 20_____.

Notary Public

My Commission expires on: _____

GENERAL CONDITIONS

ARTICLE 1: DEFINITIONS

Whenever used in these General Conditions or in the other Contract Documents, the following terms have the meanings indicated, which are applicable to both the singular and plural thereof.

Addenda: Written or graphic instruments issued prior to the opening of Bids that clarify, correct or change the bidding documents or the Contract Documents.

Agreement: The written agreement between OWNER and CONTRACTOR covering the work to be performed; other Contract Documents are attached to the Agreement and made a part thereof as provided therein.

Application for Payment: The form that is to be used by CONTRACTOR in requesting progress or final payment and which is to include such supporting documentation as is required by the Contract Documents.

Bid: The offer or proposal of the Bidder submitted on the prescribed form setting forth the prices for the work to be performed.

Bonds: Bid, performance and payment bonds and other instruments of security submitted on forms as required by Contract Documents.

Change Order: A written order to CONTRACTOR, signed by OWNER, authorizing an addition, deletion or revision in the work, or an adjustment in the Contract Price or the Contract Time issued after the effective date of the Agreement.

Contract Documents: The Agreement, Addenda (which pertain to the Contract Documents), CONTRACTOR's Bid (including documentation accompanying the Bid and any post-Bid documentation submitted prior to the Notice of Award) when attached as an exhibit to the Agreement, the Bonds, these General Conditions, the Supplementary Conditions, the Specifications, the Drawings as the same are more specifically identified in the Agreement, together with all modifications issued after the execution of the Agreement and the Instructions to Bidders.

Contract Price: The monies payable by OWNER to CONTRACTOR under the Contract Documents as stated in the Agreement.

Day: A calendar day of 24 hours measured to the next midnight.

Defective: An adjective which, when modifying the word "work," refers to work that is unsatisfactory, faulty or deficient, or does not conform to the Contract Documents or does not meet the requirements of any inspection, test or approval referred to in the Contract Documents, or has been damaged prior to ENGINEERS's recommendation of final payment.

Drawings: The drawings which show the character and scope of the work to be performed and are referred to in the Contract Documents.

Effective Date of Agreement: The date indicated in the Agreement on which it becomes effective; but, if no date is indicated, it means the date on which the Agreement is signed and delivered by the last of the two parties to sign and deliver.

ENGINEER: The person, firm or corporation named as such in the Agreement.

Modification: (a) A written amendment of the Contract documents signed by both parties, (b) a Change Order. A modification may only be issued after the effective date on the Agreement.

Notice of Award: The written notice by OWNER to the apparent Successful Bidder stating that, upon compliance by the apparent Successful Bidder with the conditions precedent enumerated therein, within the time specified, OWNER will sign and deliver the Agreement.

OWNER: The public body of authority, corporation, association, partnership or individual with whom CONTRACTOR has entered into the Agreement and from whom the work is to be provided.

Project: The total construction of which the work is to be provided under the Contract Documents may be the whole or a part, as indicated elsewhere in the Contract Documents.

Shop Drawings: All drawings, diagrams, illustrations, schedules and other data which are specifically prepared by CONTRACTOR, a SUBCONTRACTOR, manufacturer, fabricator, supplier or distributor to illustrate some portion of the work and all illustrations, brochures, standard schedules, performance charts, instructions, diagrams and other information prepared by a manufacturer, fabricator, supplier or distributor and submitted by CONTRACTOR to illustrate material or equipment for some portion of the work.

Specifications: Those portions of the Contract Documents consisting of written technical descriptions of materials, equipment, construction systems, standards and workmanship as applied to the work and certain administrative details applicable thereto.

SUBCONTRACTOR: An individual, firm or corporation having a direct contract with CONTRACTOR or with any other SUBCONTRACTOR for the performance of a part of the work at the site.

Substantial Completion: The work (or a specified part thereof) has progressed to the point where it is sufficiently complete, in accordance with the Contract Documents, so that the work (or specified part) can be utilized for the purpose for which it was intended; or, if there is no such point established, when final payment is due in accordance with Article 14. The terms “substantially complete” and “substantially completed,” as applied to any work, refer to substantial completion thereof.

Work: The entire completed construction, or the various separately identifiable parts thereof, are required to be furnished under the Contract Documents. Work is the result of performing services, furnishing labor and furnishing and incorporating materials and equipment into the construction — all as required by the Contract Documents.

GENERAL CONDITIONS

ARTICLE 2: PRELIMINARY MATTERS

Delivery of Bonds

When CONTRACTOR delivers the executed Agreements to OWNER, CONTRACTOR may be required to furnish in accordance with Article 5.

Copies of Documents

OWNER shall furnish to CONTRACTOR up to five (5) copies (unless otherwise specified in the General Requirements) of the Contract Documents as are reasonably necessary for the execution of the work. Additional copies will be furnished, upon request, at the cost of reproduction.

Commencement of Contract Time: Notice to Proceed

The contract time will be presumed to commence to run on the first day after the effective date of the Agreement, without a need for notice to proceed. Only if that is not possible, for reasons within the contract of the OWNER, then a notice to proceed shall be given by the OWNER stating the date when the contract time will commence.

Starting the Project

CONTRACTOR shall start to perform the work on the date when the contract time commences to run, but no work shall be done at the site prior to the date on which the contract time commences to run.

Before Starting Construction

1. CONTRACTOR shall start to perform the work. CONTRACTOR shall carefully study and compare the Contract Documents and check and verify pertinent figures shown thereon and all applicable field measurements. CONTRACTOR shall promptly report, in writing to ENGINEER, any conflict, error or discrepancy which CONTRACTOR may discover; however, CONTRACTOR shall not be liable to OWNER or ENGINEER for failure to report any conflict, error or discrepancy in the drawings and specifications, unless CONTRACTOR had actual knowledge thereof or should reasonably have know thereof.
2. Before work at the site is started, CONTRACTOR shall deliver to OWNER certificates (and other evidence of insurance requested by OWNER), which CONTRACTOR is required to purchase and maintain in accordance with Article 5.
3. Within 20 days after the effective date of the Agreement, but before CONTRACTOR starts the work at the site, a conference will be held for review and acceptance of the schedules to establish procedures for handling shop drawings and other submittals and for processing applications and payment and to establish a working understanding among the parties as to the work.

GENERAL CONDITIONS
ARTICLE 3: CONTRACT DOCUMENTS:
INTENT AND REUSE

Intent

1. The Contract Documents comprise the entire Agreement between OWNER and CONTRACTOR concerning the work. They may be altered only by a modification.
2. The Contract Documents are complementary; what is called for by one is as binding as if called for by all. If during the performance of the work, CONTRACTOR finds a conflict, error or discrepancy in the Contract Documents, he shall report it to ENGINEER in writing at once and before proceeding with the work affected thereby; however, CONTRACTOR shall not be liable to OWNER or ENGINEER for failure to report any conflict, error or discrepancy in the specifications or drawings unless CONTRACTOR has actual knowledge thereof or should reasonably have known thereof.
3. It is the intent of the specifications and drawings to describe a complete project (or part thereof) to be constructed in accordance with the Contract Documents. Any work that may reasonably be inferred from the specifications or drawings as being required to produce the intended result shall be applied whether or not it is specifically called for. When words that have a well-known technical or trade meaning are used to describe work, materials or equipment, such words shall be interpreted in accordance with such meaning. Reference to standard specifications, manuals or codes of any technical society, organization or association, or to the code of any governmental authority, whether such reference be specific or by implication, shall mean the latest standard specification, manual or code in effect at the time of opening of bids (or on the effective date of the Agreement if there were no bids), except as may be otherwise specifically stated. However, no provision of any referenced standard specification, manual or code (whether or not specifically incorporated by reference in the Contract Documents) shall change the duties and responsibilities of OWNER, CONTRACTOR or ENGINEER, or any of their agents or employees from those set forth in the Contract Documents.
4. The Contract Documents will be governed by the law of the place of the project.

Reuse of Documents

5. Neither CONTRACTOR nor any SUBCONTRACTOR, manufacturer, fabricator, supplier or distributor shall have or acquire any title to or ownership rights in any of the drawings, specifications or other documents (or copies of any thereof) prepared by or bearing the seal or logo of ENGINEER; and they shall not reuse any of them or part thereof on extensions of the project or any other project without the written consent of OWNER and ENGINEER and specific written verification or adaptation by ENGINEER.

GENERAL CONDITIONS
ARTICLE 4: AVAILABILITY OF LANDS,
PHYSICAL CONDITIONS, REFERENCE POINTS

Availability of Lands

CONTRACTOR shall arrange for all lands and access thereto that may be required for temporary construction facilities or storage of materials and equipment.

Physical Conditions — Investigations and Reports

Reports of investigations and tests of subsurface and latent physical conditions at the site or otherwise affecting cost, progress or performance of the work which have been relied upon by ENGINEER in preparation of the drawings and specifications — are not guaranteed as to accuracy or completeness and are not part of the Contract Documents.

Unforeseen Physical Conditions

By signing the contract, the CONTRACTOR has represented that he has fully and completely made or caused to be made at CONTRACTOR's expense, examinations, investigations, tests and studies of data in addition to those referred to in Article 6 of the Agreement, including but not limited to, subsurface conditions, soil and underground strength conditions, whether latent or not, and any underground utility structure or obstacle and any other data that may possibly be deemed pertinent to the performance of the work at the contract price, within the Contract Time, and in accordance with the other terms and conditions of the Contract Documents; and any additional examinations, investigations, tests, reports or similar data as will be required by CONTRACTOR for such purposes will be performed by CONTRACTOR or CONTRACTOR's agent at CONTRACTOR's expense. Such work should be considered incidental to contract price.

Reference Points

OWNER shall provide engineering surveys for construction to establish reference points that, in his judgment, are necessary to enable CONTRACTOR to proceed with the work. CONTRACTOR shall be responsible for laying out the work (unless otherwise specified in the General Requirements), shall protect and preserve the established reference points and shall make no changes or relocations without the prior written approval of OWNER. CONTRACTOR shall report to ENGINEER such changes being deducted from CONTRACTOR's payment estimate.

GENERAL CONDITIONS

ARTICLE 5: BONDS AND INSURANCE

Performance and Other Bonds

1. CONTRACTOR shall furnish performance, payment and maintenance and guarantee bonds, each in an amount at least equal to the contract price, as security for the faithful performance and payment of all CONTRACTOR's obligations under the Contract Documents. These bonds shall remain in effect at least until one year after the date of final payment. CONTRACTOR also shall furnish such bonds as are required in this article. All bonds shall be in the forms prescribed by the bidding documents in the state where the project is located. All bonds, signed by an agent, must be accompanied by a certified copy of the authority to act.
 - A. The insurance and bonds required herein may be increased after award of project if said increase is found reasonably necessary or required for the proper performance of the project. Said increase shall be at the CONTRACTOR's expense.
 - B. The CONTRACTOR is under a continued obligation to submit insurance and bonds as required herein. If, at any time prior to final acceptance, the OWNER discovers that any insurance or bonds required herein were either not submitted by CONTRACTOR or not submitted in full compliance with the Contract Documents, then the OWNER has the option to require the CONTRACTOR to submit insurance and bonds as required in the contract. In case of failure of CONTRACTOR to submit such bonds or insurance, the OWNER may elect any remedy that may reasonably protect the OWNER's interest. However, the originally submitted bonds and insurance would continue to have full effect and force.
 - C. All bonds shall be in the forms prescribed by the bidding documents or supplementary general conditions and be executed by such sureties as (i) are licensed to conduct business in the state where the project is located, and (ii) are named in the current list of "Companies Holding Certificates of Authority as Acceptable Sureties on Federal Bonds and as Acceptable Reinsuring Companies" as published in Circular 570 (amended) by the Audit Staff Bureau of Accounts, U.S. Treasury Department. All bonds, signed by an agent, must be accompanied by a certified copy of the authority to act.
2. If the surety on any bond furnished by CONTRACTOR is declared bankrupt, becomes insolvent or its right to do business is terminated in any state where any part of the project is located or it ceases to meet the requirements of Article 5, CONTRACTOR shall, within five (5) days thereafter, substitute another bond and surety, both of which shall be acceptable to the OWNER.

Contractor's Liability Insurance

1. The insurance certificates required herein from a part of this contract and until such required certificates are delivered to OWNER and approved by the OWNER and ENGINEER, no valid Contract shall exist between the parties hereto.
2. CONTRACTOR shall purchase and maintain such comprehensive general liability and other insurance that will provide protection from claims set forth below which may arise out of, or

result from, CONTRACTOR's performance of the work and CONTRACTOR's other obligations under the Contract Documents, whether such performance is by CONTRACTOR, by any SUBCONTRACTORS, by anyone directly or indirectly employed by any of them, or by anyone for whom acting on their behalf may be liable.

3. THE CONTRACTOR SHALL FURNISH THREE (3) CERTIFIED COPIES OF ALL CERTIFICATES OF INSURANCE POLICIES REQUESTED HEREIN. The OWNER and ENGINEER shall be named insured on each and every insurance policy required herein. The CONTRACTOR must furnish certificates for the following insurance:

A. Claims under workers' or workmen's compensation, disability benefits and other similar employee benefit acts:

- | | | |
|-----|----------------------|-----------|
| (1) | State | Statutory |
| (2) | Employer's Liability | Statutory |

B. Claims for damages because of bodily injury, occupational sickness or disease or death of CONTRACTOR's employees:

- | | | |
|-----|----------------------|-----------|
| (1) | State | Statutory |
| (2) | Employer's Liability | Statutory |

- | | | |
|-----|----------------|---|
| (3) | Bodily Injury: | |
| | \$1,000,000 | Each Occurrence |
| | \$1,000,000 | Annual Aggregate, Products and Completed Operations |

- | | | |
|-----|------------------|------------------|
| (4) | Property Damage: | |
| | \$1,000,000 | Each Occurrence |
| | \$1,000,000 | Annual Aggregate |

(5) Property Damage Liability Insurance will provide Explosion, Collapse and Underground Coverage where Applicable.

- | | | |
|-----|---|------------------|
| (6) | Personal Injury, with employment exclusion deleted: | |
| | \$1,000,000 | Annual Aggregate |

This insurance required by this Article 5 shall include the specific coverage and be written for not less than the limits of liability and coverages provided herein or in the Supplementary Condition, or required by law, whichever is greater. The comprehensive general liability insurance shall include completed operations insurance. All such insurance shall contain a provision that the coverage afforded will not be canceled, materially changed or renewal refused until at least 30 days prior written notice has been given to OWNER and ENGINEER. All such insurance shall remain in effect until final payment and, at all times thereafter, when CONTRACTOR may be correcting, removing or replacing defective work in accordance with Article 13. In addition, CONTRACTOR shall maintain such completed operations insurance for at least two (2) years after final payment and furnish OWNER and ENGINEER with evidence of continuation of such insurance at final payment and one (1) year thereafter.

2. The comprehensive general liability insurance required to Article 5 will include contractual liability insurance applicable to CONTRACTOR's obligations under Article 6.

3. The CONTRACTOR shall maintain, during the life of this contract, OWNER'S and CONTRACTOR'S Protective Liability Coverage in the name of:
 1. The OWNER
 2. The ENGINEER
 3. Others, if specifically required by special permission in the Contract Documents.

This coverage shall include the entire work. The CONTRACTOR shall furnish a Certificate of Insurance certifying that this OWNER'S and CONTRACTOR'S Protective Liability Insurance includes all SUBCONTRACTORS'S engaged in the work. The OWNER's and CONTRACTOR'S Protective Liability Coverage shall contain the following endorsement:

"It is hereby understood and agreed that such insurance as is afforded shall include specific coverage for the so-called Explosion, Collapse and Underground Hazards, which covers damage or structural injury to buildings or adjacent structures arising from operations under this Contract including excavation or tunneling and damage sustained by wires, conduits, mains, sewers and the like, occasioned by the CONTRACTOR'S sub-surface operations."

The minimum limits of liability for all coverages in the above shall be as follows, unless specifically required by special provision in the Specifications:

1. Bodily Injury Liability:

\$1,000,000	Each Person
\$1,000,000	Each Occurrence
\$1,000,000	Aggregate

2. Property Damage Liability:

\$1,000,000	Each Occurrence
\$1,000,000	Aggregate (except Auto)

In the event that an Umbrella Liability Policy is used to meet the limit requirements of the Specifications, the total limits available under the underlying coverage shall not be less than \$1,000,000.

Property Insurance

1. Unless otherwise provided in these General Conditions, CONTRACTOR shall purchase and maintain property insurance upon the work at the site to the full insurable value thereof (subject to such deductible amounts as required by law). This insurance shall include the interests of OWNER, ENGINEER, CONTRACTOR and SUBCONTRACTOR in the work, shall insure against the perils of fire and extended coverage, shall include "all risk" insurance for physical loss and damage, including theft, vandalism and malicious mischief, collapse and water damage and such other perils as may be provided in these General Conditions, and shall include damages, losses and expenses arising out of, or replacement of, any property (including fees and charges of engineers, architects, attorneys and other professionals). If not covered under the "all risk" insurance or otherwise provided in the Supplementary Conditions, CONTRACTOR shall purchase and maintain similar property insurance in transit when such portions of the work are to be included in an Application for Payment. The policies of insurance required to be purchased and maintained by CONTRACTOR in accordance with Article 5 shall contain a provision that the coverage afforded will not be

- canceled or materially changed until at least 30 days prior written notice has been given to the OWNER and ENGINEER.
2. OWNER shall not be responsible for purchasing and maintaining any property insurance to protect the interests of CONTRACTOR or SUBCONTRACTORS in the work to the extent of any deductible amounts that are provided in this contract. If CONTRACTOR wishes property insurance coverage within the limits of such amounts, CONTRACTOR may purchase and maintain it at his own expense.
 3. OWNER and CONTRACTOR waive all rights against each other and the SUBCONTRACTOR and their agents and employees and against ENGINEER and separate CONTRACTORS (if any) and their SUBCONTRACTOR's agents and employees for damages caused by fire or other perils to the extent covered by insurance provided under Article 5 or any other property insurance applicable to the work, except such rights as they may have to the proceeds of such insurance held by OWNER as trustee. CONTRACTOR shall require similar written waivers from each SUBCONTRACTOR (in accordance with Article 6 as applicable); each such waiver will be in favor of all other parties enumerated in this Article.
 4. Any insured loss under the policies of insurance required by this Article shall be adjusted with OWNER and made payable to OWNER as trustee for the insured, as their interests may appear, subject to the requirements of any applicable mortgage clause and of this Article. OWNER shall deposit, in a separate account, any money so received, and he shall distribute it in accordance with such agreement as the parties in interest may reach. If no other special agreement is reached, the damaged work shall be repaired or replaced, the monies so received applied on account thereof and the work and the cost thereof covered by an appropriate Change Order.
 5. OWNER, as trustee, shall have power to adjust and settle any loss with the insurers unless one of the parties in interest shall object in writing, within 15 days after the occurrence of loss to OWNER's exercise of this power. If such objection is made, OWNER, as trustee, shall make settlement with the insurers in accordance with such agreements as the parties in interest may reach. If required in writing by any party in interest, OWNER, as trustee, shall, upon occurrence of an insured loss, give bond for the proper performance of his duties.

Acceptance of Insurance

1. If OWNER has any objection to the coverage afforded by or other provisions of the insurance required to be purchased and maintained by CONTRACTOR in accordance with Article 5 on the basis of its not complying with the Contract Documents, OWNER will notify the CONTRACTOR in writing thereof within 30 days of the date of delivery of such certificates to OWNER in accordance with Article 2.
2. If OWNER finds it necessary to occupy or use a portion or portions of the work prior to Substantial Completion of all work, such use or occupancy may be accomplished in accordance with Article 14; provided that no such use or occupancy shall commence before the insurers providing the property insurance have acknowledged notice thereof and, in writing, effected the changes in coverage necessary thereby. The insurers provided the property insurance shall consent by endorsement on the policy or policies, but the property insurance shall not be canceled or lapse on account of any such partial use or occupancy.
3. In order to determine financial strength and reputation of insurance carriers, all companies providing the coverage required shall be licensed or approved by the Insurance Bureau of the State of Michigan and shall have a financial rating not lower than XI and a policyholder's service rating no lower than B+ as listed in A.M. Best's Key Rating Guide, current edition. Companies with ratings lower than B and XI will be acceptable only upon written consent of the OWNER.

GENERAL CONDITIONS

ARTICLE 6: CONTRACTOR'S RESPONSIBILITIES

Supervision and Superintendence

1. CONTRACTOR shall supervise and direct the work competently and efficiently, devoting such attention thereto and apply such skills and expertise as may be necessary to perform the work in accordance with the Contract Documents. CONTRACTOR shall be solely responsible for the means, methods, techniques, sequences and procedures of construction. CONTRACTOR shall be responsible to see that the finished work complies accurately with the Contract Documents.
2. CONTRACTOR shall keep on the work site at all times, during its progress, a competent resident superintendent who shall not be replaced without written notice to OWNER and ENGINEER, except under extraordinary circumstances. The superintendent will be CONTRACTOR's representative at the site and shall have authority to act on behalf of CONTRACTOR. All communications given to the superintendent shall be as binding as if given to CONTRACTOR.
3. CONTRACTOR shall provide competent, suitably qualified personnel to survey and lay out the work and perform construction as required by the Contract Documents. CONTRACTOR shall, at all times, maintain good discipline and order at the site. Except in connection with the safety or protection of persons, or the work or property at the site, or adjacent thereto, and, except as otherwise indicated herein, all work at the site shall be performed during regular working hours, and CONTRACTOR will not permit overtime work or the performance of work on Saturday, Sunday or any legal holiday without OWNER's consent.
4. CONTRACTOR shall furnish all materials, equipment, labor, transportation, construction equipment and machinery, tools, appliances, fuel, power, light, heat, telephone, water and sanitary facilities, and all other facilities and incidentals necessary for the execution, testing, initial operation and completion of the work.
5. All materials and equipment shall be of good quality and new, except as otherwise provided in the Contract Documents. If required by OWNER, CONTRACTOR shall furnish satisfactory evidence (including reports of required tests) as to the kind and quality of materials and equipment.
6. All materials and equipment shall be applied, installed, connected, erected, used, cleaned and conditioned in accordance with the instructions of the applicable manufacturer, fabricator, supplier or distributor, except as otherwise provided in the Contract Documents.
7. Whenever materials or equipment are specified or described in the drawings or specifications by using the name of a proprietary item or the name of a particular manufacturer, fabricator, supplier or distributor, the naming of the item is intended to establish the type, function and quality required. Unless the name is followed by words indicating that no substitution is permitted, materials or equipment of other manufacturers, fabricators, suppliers or distributors may be accepted by OWNER if sufficient information is submitted by CONTRACTOR to allow OWNER to determine that the material or equipment proposed is equivalent to that named. The procedure for review will be as set forth in Article 6 below or as supplemented in the General Requirements.
 - A. Requests for review of substitute items of material and equipment will not be accepted by OWNER and ENGINEER from anyone other than CONTRACTOR. If CONTRACTOR wishes to furnish or use a substitute item of material or equipment, CONTRACTOR shall make written application to OWNER through the ENGINEER for acceptance thereof, certifying that the proposed substitute will perform adequately

the functions called for by the general design, be similar and of equal substance to that specified, and be suited to the same use and capable of performing the same functions that specified. The application will state whether, in the drawing or specifications, to adapt to, the design to the substitute and whether or not the incorporation or use the substitute in connection with the work is subject to payment of any license fee or royalty. All variations of the proposed substitute from that specified shall be identified in the application, and available maintenance, repair and replacement service will be indicated. The application also will contain an itemized estimate of all costs that will result directly or indirectly from acceptance of each substitute, including costs of redesign and claims of other CONTRACTORS' affected by the resulting change. OWNER may require CONTRACTOR to furnish at CONTRACTOR's expense additional data about the proposed substitute. OWNER may require CONTRACTOR to furnish at CONTRACTOR's expense a special performance guarantee or other surety with respect to any substitute.

- B. ENGINEER will record time required by ENGINEER and ENGINEER's consultants in evaluating substitutions proposed by CONTRACTOR and in making changes in the drawings or specifications occasioned thereby. Whether or not ENGINEER accepts a proposed substitute, CONTRACTOR shall reimburse OWNER for the changes of ENGINEER and ENGINEER's consultants for evaluating any proposed substitute.

Concerning SUBCONTRACTOR

1. CONTRACTOR shall not employ any SUBCONTRACTOR or other person or organization (including those who are to furnish the principal items of materials or equipment), whether initially, or as a substitute, against whom OWNER may have any objection. Acceptance of any SUBCONTRACTOR, other person or organization by OWNER shall not constitute a waiver of any rights of OWNER to reject defective work. After the giving of the Notice of Award, if the OWNER, after the investigation, has reasonable objection to any SUBCONTRACTOR, other persons or organizations, the OWNER may request the Successful Bidder to provide an acceptable substitute without an increase in the contract price. In such a case, neither the OWNER nor the ENGINEER would be liable for any damages or remedies of either the CONTRACTOR or SUBCONTRACTOR or any other said person or organization. It is the responsibility of the CONTRACTOR to inform the SUBCONTRACTOR or other person or organization to the provision of the contract prior to the parties being contractually bound.
2. CONTRACTOR shall be fully responsible for all acts and omissions of his SUBCONTRACTOR and of persons and organizations directly or indirectly employed by them and of persons and organizations for whose acts any of them may be liable to the same extent that CONTRACTOR is responsible for the acts and omissions of persons directly employed by CONTRACTOR. Nothing in the Contract Documents shall create any contractual relationship between OWNER and ENGINEER and any SUBCONTRACTOR or other person or organization having a direct contract with CONTRACTOR, nor shall it create any obligation on the part of the OWNER or ENGINEER to pay or to see to the payment of any monies due any SUBCONTRACTOR or other persons or organizations.
3. The divisions and sections of the specifications and the identifications of any drawings shall not control CONTRACTOR in dividing the work among SUBCONTRACTORS or delineating the work to be performed by any specific trade.
4. All work performed for CONTRACTOR by a SUBCONTRACTOR will be pursuant to an appropriate agreement between CONTRACTOR and the SUBCONTRACTOR, which specifically binds the SUBCONTRACTOR to the applicable terms and conditions of the Contract Documents for the benefit of OWNER and ENGINEER, and contains waiver

provisions as required by Article 5. CONTRACTOR shall pay each SUBCONTRACTOR a just share of any insurance monies received by CONTRACTOR on account of losses under policies issued pursuant to Article 5.

Patent Fees and Royalties

1. CONTRACTOR shall pay all license fees and royalties and assume costs incidental to the use in the performance of the work or the incorporation of the work of any invention, design, process, product or device, which is the subject of patent rights or copyrights held by others.
2. The CONTRACTOR shall familiarize himself with any such possible costs prior to bidding. CONTRACTOR hereby indemnifies and holds harmless OWNER and ENGINEER and anyone directly or indirectly employed by either of them from and against all claims, damages, losses and expenses (including attorney's fees) arising out of any infringement of patent rights or copyrights incidental to the use in the performance of the work, or resulting from the incorporation of the work or any invention, design, process, product or device, and shall defend all such claims in connection with any alleged infringement of such rights.

Permits

Unless otherwise provided herein, CONTRACTOR shall obtain and pay for all construction permits and licenses. CONTRACTOR shall pay all governmental charges and inspection fees necessary for the prosecution of the work that are applicable at the time of opening of bids. CONTRACTOR shall pay all charges of utility service companies for connections to the work and for capital costs related thereto.

Laws and Regulations

CONTRACTOR shall give all notices and comply with all laws, ordinances, rules and regulations applicable to the work. If CONTRACTOR observes that the specifications and drawings are at variance therewith, CONTRACTOR shall give ENGINEER prompt written notice thereof, any necessary changes shall be adjusted by an appropriate modification. If CONTRACTOR performs any work knowing or having reasons to know that it is contrary to such laws, ordinances, rules and regulations, the CONTRACTOR shall bear all costs arising therefrom. It shall be the CONTRACTOR's responsibility to make certain that the specifications and drawings are in accordance with such laws, ordinances, rules and regulations.

Taxes

CONTRACTOR shall pay all sales, consumer, use and other similar taxes required to be paid by him in accordance with the law of the place of the project.

Use of Premises

1. CONTRACTOR shall confine construction equipment, the storage of materials and equipment and the operations of workmen to areas permitted by law, ordinances, permits or the requirements of the Contract Documents and shall not reasonably encumber the premises with construction equipment or other materials or equipment.
2. During the progress of the work, CONTRACTOR shall keep the premises free from accumulation of waste materials, rubbish and other debris resulting from the work. At the completion of the work, CONTRACTOR shall remove all waste materials, rubbish and debris from and about the premises as well as all tools, appliances, construction equipment and machinery and surplus materials, and shall leave the site clean and ready for occupancy by OWNER. CONTRACTOR shall restore, to their original condition, those portions of the site not designated for alteration by the Contract Documents.

3. CONTRACTOR shall not load and permit any part of any structure to be loaded in any manner that will endanger the structure nor shall CONTRACTOR subject any part of the work or adjacent property to stresses or pressures that will endanger it.

Record Documents

CONTRACTOR shall keep one (1) record copy of all specifications, drawings, addenda, modifications, shop drawings and samples at the site in good order and annotated to show all changes made during the construction process. These shall be available to ENGINEER for examination and shall be delivered to ENGINEER for OWNER upon completion of the work.

Safety and Protection

1. CONTRACTOR shall be solely responsible for initiating, maintaining and supervising all safety precautions and programs in connection with the work. CONTRACTOR shall take all necessary precautions for the safety of and shall provide the necessary protection to prevent damage, injury or loss to (but not limited to) the following:
 - A. All employees on the work and other persons who may be affected thereby
 - B. All the work and all materials or equipment to be incorporated therein, whether in storage on or off the site, and
 - C. Other property at the site or adjacent thereto, including trees, shrubs, lawns, walks, pavements, roadways, structures and utilities not designated for removal, relocation or replacement in the course of construction.

CONTRACTOR shall comply with all applicable laws, ordinances, rules, regulations and orders of any public body having jurisdiction for the safety of persons or property or to protect them from damage, injury or loss and shall erect and maintain all necessary safeguards for such safety and protection. CONTRACTOR shall notify owners or adjacent property and utilities when prosecution of the work may affect them. All damage, injury or loss to any property referred to in Article 6 caused, directly or indirectly, in whole or in part, by CONTRACTOR, any SUBCONTRACTOR or anyone directly or indirectly employed by any of them or anyone for who acts on behalf of them may be liable, shall be remedied by CONTRACTOR. CONTRACTOR's duties and responsibilities for the safety and protection of the work shall continue until such time as the work is completed and ENGINEER has issued a notice to OWNER and CONTRACTOR in accordance with Article 14, that the work is acceptable.

2. CONTRACTOR shall designate a responsible member of his organization at the site whose duty shall be the prevention of accidents. This person shall be CONTRACTOR's superintendent unless otherwise designated in writing by CONTRACTOR to OWNER.

Emergencies

In emergencies affecting the safety or protection or persons of the work or property at the site or adjacent thereto, CONTRACTOR, without special instruction or authorization from ENGINEER or OWNER, is obligated to act to prevent threatened damage, injury or loss. CONTRACTOR shall give ENGINEER prompt written notice of any significant changes in the work or deviations from the Contract Documents caused thereby.

Shop Drawings and Samples

1. After checking and verifying all field measurements, CONTRACTOR shall submit to ENGINEER for review, in accordance with the accepted schedule of shop drawings submission (see Article 2), five (5) copies (unless otherwise specified in the General

- Requirements) of all shop drawings will be complete with respect to dimensions, design criteria, materials of construction and like information to enable ENGINEER to review the information as required. The review by the ENGINEER is for the purpose of familiarizing the ENGINEER with the work of the CONTRACTOR and does not constitute an approval by the ENGINEER of any of the submitted material. The CONTRACTOR is solely responsible for the correctness and accuracy of all submitted material.
2. CONTRACTOR also shall submit to ENGINEER for review, with such promptness as to cause no delay in work, all samples required by the Contract Documents. All samples will have been checked by and stamped with the approval of CONTRACTOR, identified clearly as to materials, manufacturer, any pertinent catalog numbers and the use for which intended. The review of the ENGINEER is for the purpose of familiarizing the ENGINEER with the work of the CONTRACTOR and does not constitute an approval by the ENGINEER of any of the submitted materials. The CONTRACTOR is solely responsible for the correctness and accuracy of all submitted material.
 3. At the time of each submission, CONTRACTOR shall, in writing, call ENGINEER's attention to any deviations that the shop drawings or samples may have from the requirements of the Contract Documents.
 4. ENGINEER will review the shop drawings and samples, but ENGINEER's review shall be only for general and approximate conformance with the design concept of the project and for general and approximate compliance with the information given in the Contract Documents and shall not extend to means, methods, sequences, techniques or procedures of construction or to safety precautions or programs incident thereto. The review of a separate item as such will not indicate a review of the assembly in which the item functions. CONTRACTOR shall make any corrections required by ENGINEER and shall return the required number of corrected copies of shop drawings and resubmit new samples for review (as stated above for general and approximate compliance). CONTRACTOR shall direct specific attention, in writing, to reviews other than the correction called for by ENGINEER on previous submittals. CONTRACTOR's stamp of approval on any shop drawing or samples shall constitute a representation to OWNER and ENGINEER that CONTRACTOR has determined and verified all quantities, dimensions, field construction criteria, materials, catalog numbers and similar data and assumes full and sole responsibility for doing so, and that CONTRACTOR has reviewed or coordinated each shop drawing or sample with the requirements of the work and the Contract Documents.
 5. Where a shop drawing or sample is required by the specifications, no related work shall be commenced until the submittal has been reviewed by ENGINEER.
 6. ENGINEER's review of shop drawings or samples shall not relieve CONTRACTOR from any responsibility for any deviations from the Contract Documents unless CONTRACTOR has, in writing, called ENGINEER's attention to such deviation at the time of submission and ENGINEER has given written concurrence and approval to the specific deviation at the time of submission and ENGINEER has given written concurrence and approval to the specific deviation, nor shall any concurrence or approval by ENGINEER relieve CONTRACTOR from his sole responsibility for error or omissions in the shop drawings.
 7. CONTRACTOR shall carry on the work and maintain the progress schedule during all disputes or disagreements with OWNER, including, but not limited to, disputes and disagreements concerning change of conditions, change of quantities or change of scope of work. No work shall be delayed or postponed pending resolution of any damages or disagreements, except as CONTRACTOR and OWNER may otherwise agree in writing.

Indemnification

1. To the fullest extent permitted by law, CONTRACTOR agrees to indemnify, defend and save harmless the OWNER their officials, employees and agents, from and against all claims,

- damages, loss or expense (including, but not limited to, costs and attorney fees) by reason of any liability asserted or imposed upon the OWNER, their officials, agents or employees, for damages because of bodily injury, including death, at any time resulting therefrom, sustained by any person or persons or on account of damage to property including loss of use thereof, arising out of, or in consequence of, the performance of the work described herein, whether such injuries to persons or damage to property is due, or claimed to be due, directly or indirectly, to the negligence or omission of the CONTRACTOR, any SUBCONTRACTOR, the OWNER or their officials, employees or agents.
2. In any and all claims against OWNER and ENGINEER or any of their agents or employees by any employee of CONTRACTOR, any SUBCONTRACTOR, anyone directly or indirectly employed by any of them or anyone for whose acts any of them may be liable, the indemnifications obligation under Article 6 shall not be limited, in any way, by any limitation, on the amount or type of damages, compensation or benefits payable by or for CONTRACTOR or any SUBCONTRACTOR, under workers' or workmen's compensation acts, disability benefit acts or other employee benefit acts.

GENERAL CONDITIONS

ARTICLE 7: WORK BY OTHERS

OWNER may perform additional work related to the Project by himself or have additional work performed by utility service companies or other direct contracts that shall contain General Conditions similar to these. CONTRACTOR shall afford the utility service companies and the other CONTRACTORS, who are parties to such direct contracts (or OWNER, if OWNER is performing the additional work with OWNER'S employees) all possible opportunity for the introduction and storage of materials and equipment and the execution of work and shall properly connect and coordinate his work with theirs.

If any part of CONTRACTOR'S work depends, for proper execution of results, upon the work of any such other CONTRACTOR or utility service company (or OWNER), CONTRACTOR shall inspect and promptly report to ENGINEER, in writing, defects or deficiencies in such work that render it unsuitable for such proper execution and results. CONTRACTOR'S failure to report shall constitute an acceptance of the other work as fit and proper for integration with CONTRACTOR'S work except for latent or non-apparent defects and deficiencies in the other work.

CONTRACTOR shall do all cutting, fitting and patching of his work that may be required to make its several parts come together properly and integrate with such other work. CONTRACTOR shall not endanger any work of others by cutting, excavating or otherwise altering their work.

If the performance of additional work by other CONTRACTORS or utility service companies or OWNER was not noted in the Contract Documents, written notice, thereof, shall be given to CONTRACTOR prior to starting any such additional work.

GENERAL CONDITIONS
ARTICLE 8: OWNER'S RESPONSIBILITY

OWNER shall issue all communications to CONTRACTOR through ENGINEER.

The ENGINEER is designated as the representative of the OWNER during the period of the contract. Since ENGINEER had relied on this employment by OWNER, ENGINEER is entitled to all damages and remedies in law and equity in case of termination by OWNER.

GENERAL CONDITIONS

ARTICLE 9: ENGINEER'S STATUS DURING CONSTRUCTION

Owner's Representative

ENGINEER will be OWNER's representative during the construction period, but authority to bind the OWNER is limited as set forth in Article 10 of these General Conditions.

Visits to Site

ENGINEER, through the ENGINEER's inspector and construction engineer, will make visits to the site at intervals appropriate to the various stages of construction, and possibly on a daily basis, to observe the progress and quality of the executed work. ENGINEER's inspector will not be required to make exhaustive or continuous on-site inspections to check the quality or quantity of the work. ENGINEER's efforts will be directed toward providing for OWNER a greater degree of confidence that the completed work will conform to the contract documents. On the basis of such visits and on-site observations, ENGINEER will keep OWNER informed of the progress of the work. Limitations on responsibility of ENGINEER, stated above, shall not be deemed altered even if ENGINEER has full-time inspector on the site.

Clarifications and Interpretations

ENGINEER may issue, within a reasonable time, such written clarifications or interpretations of the contract documents (in the form of drawings or otherwise) as ENGINEER may determine necessary. No increase in contract price or contract time is justified or allowed if the clarification or interpretation of the contract documents is inferable from the overall intent of the contract documents.

Project Presentation

If OWNER and ENGINEER agree, ENGINEER will furnish an inspector to assist OWNER in observing the performance of the work. The duties, responsibilities and limitations of authority of any such inspectors, construction engineers and assistants will be provided in Article 9 above.

Decisions on Disagreements

ENGINEER will be the initial interpreter of the requirements of the contract documents. Claims, disputes and other matters relating to the acceptability of the work or the interpretation of the requirements of the contract documents pertaining to the execution and progress of the work shall be referred initially to ENGINEER in writing with a request for a formal decision in accordance with this paragraph, which ENGINEER will render within the time the ENGINEER deems required to complete any related investigation of the claim. Written notice of each such claim, dispute and other matter shall be delivered by the claimant to ENGINEER and other party to the Agreement within 15 days of the occurrence of the event, giving rise thereto, together with any supporting data. In his capacity as interpreter, ENGINEER will not be liable in connection with any interpretation or decision rendered in good faith in such capacity.

The rendering of a decision by ENGINEER pursuant to Article 9 with respect to any such claim, dispute or other matter (except any which have been waived by the marking or acceptance of final payment as provided in Article 14) will be a condition precedent to any exercise by OWNER or CONTRACTOR of such rights or remedies as either may otherwise have under the contract documents or at law in respect of any such claim, dispute or other matter.

Limitations on ENGINEER'S Responsibility

1. Neither ENGINEER's authority to act under this Article 9 or elsewhere in the contract documents, nor any decision made by ENGINEER, either to exercise, or not exercise such authority, shall give rise to any duty or responsibility of ENGINEER to CONTRACTOR, or any SUBCONTRACTOR, any manufacturer, fabricator, supplier or distributor, or any of their agents or employees or any other person performing any of the work.
2. Whenever in the contract documents the terms "as ordered," "as directed," "as required," "as allowed," or terms of like effect or import are used, or the adjectives "reasonable," "suitable," "acceptable," "proper" or "satisfactory," or adjectives of like effect or import are used to describe requirement, direction, review or judgment of ENGINEER as to the work, it is intended that such requirement, direction, review or judgment will be solely to evaluate the work for compliance with the contract documents. The use of any such term or adjective never indicates that ENGINEER shall have authority to undertake responsibility contrary to the provisions of Article 9.
3. ENGINEER will not be responsible for any of CONTRACTOR's means, methods, techniques, sequences or procedures of construction, or the safety precautions and programs incident thereto, and ENGINEER will not be responsible for any of CONTRACTOR's failure to perform the work in accordance with the contract documents. The CONTRACTOR shall be solely responsible for any of CONTRACTOR's means, methods, techniques, sequences or procedures, or the safety precautions and programs incidents thereto.
4. ENGINEER will not be responsible for the acts or omissions of CONTRACTOR or of any SUBCONTRACTORS or of the agents or employees of any CONTRACTOR or SUBCONTRACTOR or of any persons at the site or otherwise performing any of the work. The CONTRACTOR will be solely responsible for the acts or omissions of CONTRACTOR or of any SUBCONTRACTOR or of any other persons at the site or otherwise performing any of the work.

GENERAL CONDITIONS

ARTICLE 10: CHANGES IN THE WORK

Without invalidating the Agreement, OWNER may, at any time, or from time to time, order additions, deletions or revisions in the work; these will be authorized by Change Orders. Upon receipt of a Change Order, CONTRACTOR shall proceed with the work involved. All such work shall be executed under the applicable conditions of the contract documents. If any Change Order causes a decrease in the contract price or a shortening of the contract time, an equitable adjustment will be made.

ENGINEER may authorize changes in the work, which, in his judgment, are reasonably required for the proper fulfillment of the contract.

Additional work performed without authorization will not entitle CONTRACTOR to an increase in the contract price or an extension of the contract time, except in the case of an emergency as provided in Article 6 and except as provided in this Article.

OWNER shall execute appropriate Change Orders prepared by ENGINEER covering changes in the work, which are required by OWNER or required because of emergencies or because of uncovering work found not to be defective or as provided in Article 11 or because of any other claim of CONTRACTOR for a change in the contract time or the contract price, which is recommended by ENGINEER.

If notice of any change affecting the general scope of the work or change in the contract price is required by the provisions of any bond to be given to the surety, it will be CONTRACTOR'S sole responsibility to so notify the surety, and the amount of each applicable bond shall be adjusted accordingly. CONTRACTOR shall furnish proof of such adjustment to OWNER and ENGINEER without the need for either OWNER or ENGINEER requesting such proof.

GENERAL CONDITIONS

ARTICLE 11: CHANGE OF CONTRACT PRICE

The contract price constitutes the total compensation (subject to authorized adjustment) payable to CONTRACTOR for performing the work. All duties, responsibilities and obligations assigned to or undertaken by CONTRACTOR shall be at his expense without change in the contract price.

The contract price may only be changed by a Change Order. Any claim for an increase in the Contract Price shall be based on written notice delivered to OWNER and ENGINEER within 15 days of the occurrence of the event, giving rise to the claim. Notice of the amount of the claim with supporting data shall be delivered within 30 days of such occurrence unless ENGINEER allows an additional period of time to ascertain accurate cost data. All claims for adjustment in the contract price shall be determined by ENGINEER if OWNER and CONTRACTOR cannot otherwise agree on the amount involved.

The value of any work covered by a Change Order, or of any claim for an increase or decrease in the contract price, shall be determined in one of the following ways:

1. Where the work involved is covered by unit prices contained in the Contract Documents, by application of unit prices to the quantities of the items involved (subject to the provisions of Article 11).
2. By mutual acceptance of a lump sum.
3. On the basis of the cost of the work (determined as provided in Article 11) plus a CONTRACTOR's fee for overhead and profit (determined as provided in Article 11).

Cost of the Work

The term "cost of the work" means the sum of all costs necessarily incurred and paid by CONTRACTOR in the proper performance of the work. Except as otherwise may be agreed to in writing by OWNER, such costs shall be in amounts no higher than those prevailing in the locality of the project, shall include only the following items, and shall not include any of the costs itemized in Article 11.

1. The payroll costs for employees necessary for efficient and acceptable production in the direct employ of CONTRACTOR in the performance of the work under schedules of job classifications agreed upon by OWNER and CONTRACTOR. Payroll costs for employees not employed full time on the work shall be apportioned on the basis of their time spent on the work. Payroll costs shall include, but not be limited to, salaries and wages, plus the cost of fringe benefits which shall include social security contributions, unemployment, excise and payroll taxes, workers' or workmens' compensation, health and retirement benefits, bonuses, sick leave, vacation and holiday pay applicable thereto. Such employees shall include superintendents and foremen at the site. The expenses of performing work after regular working hours, on Sunday or legal holidays, shall be included in the above to the extent authorized by OWNER.
2. Cost of materials and equipment furnished and incorporated in the work provided those materials and equipment are necessary for efficient and acceptable production as determined by ENGINEER.
3. Payments made by CONTRACTOR to the SUBCONTRACTORS for Work performed by SUBCONTRACTORS. If required by OWNER, CONTRACTOR shall obtain competitive bids from SUBCONTRACTORS acceptable to CONTRACTOR and shall deliver such bids

to OWNER who will then determine, with the advice of ENGINEER, which bids will be acceptable. If a SUBCONTRACTOR provides that the SUBCONTRACTOR is to be paid on the basis of cost of the work plus a fee, the SUBCONTRACTOR's cost of the work shall be determined in the same manner as CONTRACTOR's cost of the work. All subcontracts shall be subject to the other provisions of the Contract Documents insofar as applicable.

The term "cost of the work" shall not include any of the following:

1. Payroll costs and other compensation of CONTRACTOR's officers, executives, principals (of partnership and sole proprietorships), general managers, engineers, architects, estimators, lawyers, auditors, accountants, purchasing and contracting agents expeditors, timekeepers, clerks and other personnel employed by CONTRACTOR, whether at the site or in his principal, or a branch office for general administration of the work and not specifically included in the agreed upon schedule of job classifications referred to in Article 11 — all of which are to be considered administrative costs covered by the CONTRACTOR's fee.
2. Expenses of CONTRACTOR's principal and branch offices, other than CONTRACTOR's office at the site.
3. Any part of CONTRACTOR's capital expenses, including interest on CONTRACTOR's capital employed for the work and charges against CONTRACTOR for delinquent payment.
4. Cost of premiums for all bonds and for all insurance, whether or not CONTRACTOR is required by the Contract Documents to purchase and maintain the same, including additional bonds and insurance required because of changes in the work.
5. Costs due to the negligence of CONTRACTOR, any SUBCONTRACTOR, or anyone directly or indirectly employed by any of them or for whose acts any of them, may be liable, including, but not limited to, the correction of defective work, disposal of materials or equipment wrongly applied and making good any damage to property.
6. Other overhead or general expense costs of any kind and the costs of any item not specifically and expressly included in this Article.

The CONTRACTOR's fee allowed to CONTRACTOR for overhead and profit shall not exceed 15 percent of cost of labor and materials.

For costs incurred under this Article, the CONTRACTOR's fee shall be five percent (5%); and if a subcontract is on the basis of cost of the work plus a fee, the maximum allowable to the SUBCONTRACTOR as a fee for overhead and profit shall be 10 percent.

The amount of credit to be allowed by CONTRACTOR to OWNER for any such charge that which results in a net decrease in cost will be the amount of the actual net decrease. When both additions and credits are involved in any one change, the combined overhead and profit shall be figured on the basis of the net increase, if any.

Whenever the cost of any work is to be determined pursuant to this Article, CONTRACTOR will submit, in form acceptable to ENGINEER, an itemized cost breakdown together with supporting data.

Where the quantity of the work with respect to any item that is covered by a unit price differs materially and significantly from the quantity of such work indicated in the Contract Documents, an appropriate Change Order may be issued on recommendation of ENGINEER to adjust the unit price.

In general, if the actual quantity of work is within 25 percent of the quantity indicated in the Contract Documents (whether more or less), the difference shall not be considered material or significant. For larger differences, the ENGINEER's decision as to whether the amount of actual quantity of work is materially and significantly different from the quantity indicated on the Contract Documents is final.

Cash Allowances

It is understood that CONTRACTOR has included in the contract price all allowances so named in the Contract Documents and shall cause the work so covered to be done by such SUBCONTRACTORS, manufacturers, fabricators, suppliers or distributors and for such sums within the limit of the allowances as may be acceptable to ENGINEER. CONTRACTOR agrees that the original contract price includes such sums as CONTRACTOR deems proper for costs and profit on account of cash allowances. No demand for additional cost or profit in connection will be valid.

GENERAL CONDITIONS

ARTICLE 12: CHANGE OF CONTRACT TIME

The contract time may only be changed by a Change Order. Any claim for an extension in the contract time shall be based on written notice delivered to OWNER and ENGINEER within 15 days of the occurrence of the event, giving rise to the claim. Notice of the extent of the claim with supporting data shall be delivered within 30 days of such occurrence unless ENGINEER allows an additional period of time to ascertain more accurate data. All claims for adjustment in the contract time shall be determined by ENGINEER if OWNER and CONTRACTOR cannot otherwise agree. Any change in the contract time resulting from any such claim shall be incorporated in a Change Order.

The contract time will be extended in an amount equal to time lost due to delays beyond the control of CONTRACTOR, if a claim is made, therefore, as provided in this Article. Such delays shall include, but not be limited to, acts or neglect by OWNER or others performing additional work as contemplated by Article 7 or to fires, floods, epidemics or acts of God, but not labor disputes or severe weather conditions.

All time limits for CONTRACTOR stated in the Contract Documents are of the essence to the OWNER and are incorporated, as such, in the contract.

GENERAL CONDITIONS
ARTICLE 13: WARRANTY AND GUARANTEE
TESTS AND INSPECTIONS CORRECTION, REMOVAL OR
ACCEPTANCE OF DEFECTIVE WORK

Warranty and Guarantee

CONTRACTOR warrants and guarantees to OWNER and ENGINEER that all work will be in accordance with the Contract Documents and will not be defective. All defective work, whether or not in place, may be rejected, corrected or accepted as provided in this Article 13.

Tests and Inspections

CONTRACTOR shall give OWNER's representative timely notice of readiness of the work for all required inspections, tests or approvals.

If any law, ordinance, rule, regulation, code or order of any public body having jurisdiction requires any work (or part thereof) to specifically be inspected, tested or approved, CONTRACTOR shall assume full responsibility therefore, pay all costs in connection therewith, and furnish OWNER the required certificates of inspection, testing or approval. CONTRACTOR also shall be responsible for, and shall pay all costs in connection with, any inspection or testing required in connection with OWNER's acceptance of a manufacturer, fabricator, supplier or distributor of materials or equipment submitted for approval prior to CONTRACTOR's purchase thereof for incorporation in the work.

If any work that is to be inspected, tested or approved is covered without concurrence of OWNER'S representative, it must, if required by OWNER, be uncovered for observation. Such uncovering shall be at CONTRACTOR's expense.

Neither observations by ENGINEER nor inspectors, tests or approvals by ENGINEER, OWNER or others shall relieve CONTRACTOR from any of his obligations to perform the work in accordance with the Contract Documents.

Owner May Stop the Work

If the work is defective or CONTRACTOR fails to supply sufficient skilled workmen or suitable materials or equipment, OWNER may order CONTRACTOR to stop the work, or any portion thereof, until the cause of such order has been eliminated. CONTRACTOR shall incur all the expenses related directly or indirectly to such work stoppage.

Correction or Removal of Defective Work

If required by OWNER, CONTRACTOR shall promptly, without cost to OWNER, either correct any defective work, whether or not fabricated, installed or completed, or, if the work has been rejected by ENGINEER, remove it from the site and replace it with non-defective work without any change in Contract Price.

Two-Year Correction Period

If within two (2) year after the date of substantial completion, or such longer period of time as may be prescribed by law or by the terms of any applicable special guarantee required by the Contract Documents or by any specific provision of the Contract Documents, any work is found to be defective, CONTRACTOR shall promptly, without cost to OWNER, and in accordance with OWNER's written instructions, either correct such defective work or, if it has been rejected by

OWNER, remove it from the site and replace it with non-defective work. If CONTRACTOR does not promptly comply with the terms of such instructions, or, in an emergency, where delay would cause serious loss or damage, OWNER may have the defective work corrected or the rejected work removed and replaced, and all direct and indirect costs of such removal and replacement, including compensation for additional professional services, shall be paid by CONTRACTOR.

Acceptance of Defective Work

If, instead of requiring correction or removal and replacement of defective work, OWNER prefers to accept it, OWNER may do so. In such case, if acceptance occurs prior to ENGINEER's recommendation of final payment, a Change Order shall be issued incorporating the necessary revisions in the Contract Documents, including appropriate reduction in the contract price or, if the acceptance occurs after such recommendation, an appropriate amount shall be paid by CONTRACTOR to OWNER.

If CONTRACTOR fails, within a reasonable time after written notice to proceed, to correct defective work or to remove and replace rejected work in accordance with Article 13, or if CONTRACTOR fails to perform the work in accordance with the Contract Documents (including any requirements of the progress schedule. OWNER may exclude CONTRACTOR from all or part of the site, take possession of all or part of the work, and suspend CONTRACTOR's services related thereto, take possession of CONTRACTOR's tools, appliances, construction equipment and machinery at the site and incorporated in the work all materials and equipment stored at the site or for which OWNER has paid CONTRACTOR but which are stored elsewhere. CONTRACTOR shall allow OWNER, OWNER's representatives, agents and employees such access to the site as may be necessary to enable OWNER to exercise his rights under this paragraph. All direct and indirect costs of OWNER in exercising such rights shall be charged against CONTRACTOR, and a Change Order shall be issued incorporating the necessary revisions in the Contract Documents and a reduction in the contract price. Such direct and indirect costs shall include, in particular, but without limitation, compensation for additional professional services required and all costs of repair and replacement of work of others destroyed or damaged by correction, removal or replacement of CONTRACTOR's defective work. CONTRACTOR shall not be allowed an extension of the contract time because of any delay in performance of the work attributed to the exercise by OWNER of OWNER's rights hereunder.

GENERAL CONDITIONS

ARTICLE 14: PAYMENTS TO CONTRACTOR AND COMPLETION

Schedules

At least 10 days prior to submitting the first Application for a progress payment, CONTRACTOR shall (except as otherwise specified in the General Requirements) submit to OWNER a progress schedule, a final schedule of shop drawing submission and, where applicable, a schedule of values shall include quantities and unit prices aggregating the contract price and shall subdivide the work into component parts. These schedules are submitted strictly as information that may help the OWNER in scheduling and shall not be construed as binding the OWNER to pay the CONTRACTOR in accordance with such values if used in the progress payment.

Application for Progress Payment

At least 10 days before progress payment falls due (but not more often than once a month), CONTRACTOR shall submit to ENGINEER for review an Application for Payment filled out and signed by CONTRACTOR covering the work completed as of the date of the Application and accompanied by supporting documentation. Each subsequent Application for Payment shall include an affidavit of CONTRACTOR stating that all previous progress payments received on account of the work have been applied to discharge in full all of CONTRACTOR's obligations reflected in prior Applications for Payment. Retainage with respect to progress payments will be at least 10 percent, unless state law required otherwise.

CONTRACTOR's Warranty of Title

CONTRACTOR warrants and guarantees that title to all work, materials and equipment covered by any Application for Payment, whether incorporated in the project or not, will pass to OWNER at the time of payment free and clear of all liens, claims, security interests and encumbrances (hereafter in these General Conditions referred to as "Liens").

Review of Applications for Progress Payment

ENGINEER will, within 15 days after receipt of each Application for Payment, either indicate in writing a recommendation of payment and present the Application to OWNER or return the Application to CONTRACTOR indicating, in writing, ENGINEER's reasons for refusing to recommend payment. In the latter case, CONTRACTOR may make the necessary corrections and resubmit the Application. OWNER shall, within 25 days of presentation to him of the Application for Payment with ENGINEER's recommendation, pay CONTRACTOR the amount recommended.

By recommending any payments to the CONTRACTOR, ENGINEER will not thereby be deemed to have represented that exhaustive or continuous on-site inspections have been made to check the quality or the quantity of the work or that the means, methods, techniques, sequences and procedures of construction have been reviewed or that any examination has been made to ascertain how or for what purpose, CONTRACTOR has used the monies paid or to be paid to CONTRACTOR on account of the contract price or that title or any work, materials or equipment has passed to OWNER free and clear of any liens.

ENGINEER may refuse to recommend the whole or any part of any payment if, in his opinion, it would be incorrect to make such recommendation to OWNER. He also may refuse to recommend any such payment or, because of subsequently discovered evidence or the results of subsequent

inspections or tests, nullify such payment previously recommended to such extent as may be reasonable in ENGINEER's opinion to protect OWNER from loss because:

1. The work is defective or completed work has been damaged requiring correction or replacement.
2. Written claims have been made against OWNER or liens have been filed in connection with the work.
3. The contract price has been reduced because of modifications.
4. OWNER has been required to correct defective work or complete the work in accordance with Article 13.
5. Of CONTRACTOR's unsatisfactory prosecution of the work in accordance with the Contract Documents.
6. CONTRACTOR's failure to make payment to SUBCONTRACTORS or for labor, materials or equipment.
7. Previous overpayments to CONTRACTOR.

Substantial Completion

When CONTRACTOR considers the entire work ready for its intended use, CONTRACTOR shall, in writing to OWNER and ENGINEER, certify that the entire work is substantially complete and request that ENGINEER issue a certificate of Substantial Completion. Within a reasonable time thereafter, CONTRACTOR, ENGINEER, and/or OWNER shall make an inspection of the work to determine the status of completion. If ENGINEER does not consider the work substantially complete, ENGINEER will notify CONTRACTOR, giving his reasons therefore. If ENGINEER considers the work substantially complete, ENGINEER may prepare and deliver to OWNER a Statement of Substantial Completion, which may fix the date of Substantial Completion. There also may be attached to the statement a tentative list of items to be completed or corrected before final payment. OWNER shall have 21 days after receipt of the certificate or attached list. If, after considering such objections, ENGINEER concludes that the work is not substantially complete, ENGINEER will, within 21 days, notify CONTRACTOR, in writing, stating his reasons therefore.

OWNER shall have the right to exclude CONTRACTOR from the work after the date of substantial completion, but OWNER shall allow CONTRACTOR reasonable access to complete or correct items on the tentative list.

Partial Utilization

Use of OWNER of completed portions of the work may be accomplished prior to substantial completion of all the work subject to the following:

1. OWNER, at any time, may request CONTRACTOR, in writing, to permit OWNER to use any part of the work that OWNER believes to be substantially complete and which may be used without significant interference with construction of the other parts of the work.
2. In lieu of the issuance of a Certificate of Substantial Completion as to part of the work, OWNER may take over operation of a facility constituting part of the work whether or not it is substantially complete if such facility is functionally and separately useable; provided that prior to any such takeover, OWNER and CONTRACTOR have agreed as to the division of responsibilities between OWNER and CONTRACTOR for security, operation, safety, maintenance, correction period, heat, utilities and insurance with respect to such facility.

Final Application for Payment

After CONTRACTOR has completed all the work and delivered all maintenance and operating instructions, schedules, guarantees, Bonds, certificates of inspection, marked-up record documents

and other documents — all as required by the Contract Documents — and after ENGINEER has indicated that the work appears to be acceptable (subject to the provisions of this Article), CONTRACTOR may make application for final payment following the procedure for progress payments. The final Application for Payment shall be accompanied by all documentation called for in the Contract Documents and such other data and schedules as OWNER may reasonably require, together with complete and legally effective releases or waivers (satisfactory to OWNER) of all liens arising out of, or filed in connection with, the work. In lieu thereof, and as approved by OWNER, CONTRACTOR may furnish receipts or releases in full; an affidavit of CONTRACTOR that the releases and receipts include all labor, services, material and equipment for which a lien could be filed; and that all payrolls, material and equipment bills, and other indebtedness or otherwise satisfied; and consent of the surety, if any, to final payment. If any SUBCONTRACTOR, manufacturer, fabricator, supplier or distributor fails to furnish a release or receipt in full, CONTRACTOR may furnish a bond or other collateral satisfactory to OWNER to indemnify OWNER against any lien.

Final Payment and Acceptance

If, on the basis of ENGINEER's review of the final Application for Payment and accompanying documentation — all as required by the Contract Documents — ENGINEER is satisfied that the work has been completed and CONTRACTOR has fulfilled his obligations under the Contract Documents, ENGINEER may, within 20 days after receipt of the final Application for Payment, indicate in writing his recommendation of payment and present the Application to OWNER for payment. Thereupon, ENGINEER will give written notice to OWNER and CONTRACTOR that the work is acceptable subject to the provisions of this Article. Otherwise, ENGINEER will return the Application to CONTRACTOR indicating, in writing, the reasons for refusing to recommend final payment, in which case CONTRACTOR shall make the necessary corrections and resubmit the Application. If the Application and accompanying documentation are appropriate as to form and substance, OWNER shall, within 30 days after receipt thereof, pay CONTRACTOR the amount recommended by ENGINEER.

CONTRACTOR's Continuing Obligation

CONTRACTOR's obligation to perform and complete the work in accordance with the Contract Documents shall be absolute. Neither recommendation of any progress or final payment by ENGINEER nor the recommendation of any progress or final payment by ENGINEER nor the issuance of a notice of acceptability by ENGINEER pursuant to Article 14 nor any correction of defective work by OWNER shall constitute an acceptance of work not in accordance with the Contract Documents or a release of CONTRACTOR's obligation to perform the work in accordance with the Contract Documents.

Waiver of Claims

The making and acceptance of final payment shall:

1. Not constitute any waiver of any claims by OWNER against CONTRACTOR, including claims arising from unsettled liens, from defective work appearing after final inspection or from failure to comply with the Contract Documents or the terms of any special inspection or from failure to comply with the Contract Documents or the terms of any special guarantees specified therein; also, it shall not constitute a waiver by OWNER of any rights in respect of CONTRACTOR's continuing obligations under the Contract Documents; and
2. Constitute a waiver of all claims by CONTRACTOR against OWNER other than those previously made in writing and still unsettled.

GENERAL CONDITIONS

ARTICLE 15: SUSPENSION OF WORK AND TERMINATION

OWNER May Suspend Work

OWNER may, at any time, and without cause, suspend the work or any portion thereof for a period of not more than 120 days by notice, in writing, to CONTRACTOR. CONTRACTOR shall resume the work with 2 weeks notice by OWNER. CONTRACTOR will be allowed an increase in the Contract Price only as attributable to demobilization and remobilization cost and not to any other expense, including rental fee during suspension. The CONTRACTOR shall have the sole duty of informing, in advance, all SUBCONTRACTORS and any interested parties about the provision. OWNER and ENGINEER are not liable for any loss of any party arising out of invoking this section.

OWNER May Terminate

Upon the occurrence of any one or more of the following events:

1. If CONTRACTOR is adjudged bankrupt or insolvent.
2. If CONTRACTOR makes a general assignment for the benefit of creditors.
3. If a trustee or receiver is appointed for CONTRACTOR or for any of CONTRACTOR's property.
4. If CONTRACTOR files a petition to take advantage of any debtor's act or to reorganize under the bankruptcy or similar laws.
5. If CONTRACTOR repeatedly fails to supply sufficient skilled workmen or suitable materials or equipment.
6. If CONTRACTOR fails to make payments to SUBCONTRACTORS or for labor, materials or equipment within 60 days of receiving said payment from OWNER.
7. If CONTRACTOR disregards laws, ordinances, rules, regulations or orders of any public body having jurisdiction.
8. If CONTRACTOR disregards the authority of ENGINEER.
9. If CONTRACTOR otherwise violates, in any substantial way, any provisions of the Contract Documents. Restoration work always shall be deemed as a substantial provision of the Contract Documents.

OWNER may, after giving CONTRACTOR and his surety seven (7) days' written notice, terminate the services of CONTRACTOR, exclude CONTRACTOR from the site and take possession of the work and of all CONTRACTOR's tools, appliances, construction equipment and machinery at the site and use the same to the full extent they could be used by CONTRACTOR (without liability to CONTRACTOR for trespass or conversion), incorporating in the work all materials and equipment stored at the site for which OWNER has paid CONTRACTOR but which are stored elsewhere, and finish the work as OWNER may deem expedient. In such case, CONTRACTOR shall pay the difference to OWNER. Such costs incurred by OWNER shall be verified by ENGINEER and incorporated in a Change Order; but, in finishing the work, OWNER shall not be required to obtain the lowest figure for the work performed.

Where CONTRACTOR's services have been so terminated by OWNER, the termination shall not affect any rights of OWNER against CONTRACTOR then existing or which may thereafter accrue. Any retention or payment of monies due CONTRACTOR by OWNER will not release CONTRACTOR from liability.

Upon seven (7) days' written notice to CONTRACTOR, OWNER may, without cause and without prejudice to any of the OWNER's other rights or remedies, elect to abandon the work and terminate the Agreement with the CONTRACTOR. In such a case, CONTRACTOR shall be paid for work executed and demobilization expenses only.

GENERAL CONDITIONS

ARTICLE 16: MISCELLANEOUS

Giving Notice

Whenever any provision of the Contract Documents requires the giving of written notice to the CONTRACTOR, it shall be deemed to have been validly given if delivered in person to the individual or to a member of the firm or to an officer of the corporation for whom it is intended, or if delivered at or sent by mail to the last business address known to the giver of the notice. Notice to the ENGINEER is validly given if mailed by certified mail to his business office.

Computation of Time

When any period of time is referred to in the Contract Documents by days, it shall be computed to exclude the first and include the last day of such period. If the last day of any such period falls on a Saturday or Sunday or on a day made a legal holiday by the law of the applicable jurisdiction such day shall be omitted from the computation.

General

The duties and obligations imposed by these General Conditions upon the CONTRACTOR and, in particular but without limitation, the warranties, guarantees and obligations imposed upon CONTRACTOR by Articles 6, 13, 14 and 15 and all of the rights and remedies available to either ENGINEER or OWNER which are otherwise imposed or available by law or contract, by special warranty or guarantee or by other provisions of the Contract Documents, and the provisions of the Contract Documents in connection with each particular duty, obligation, right and remedy to which they apply. All representations, warranties and guarantees made in Contract Documents by CONTRACTOR shall survive final payment and termination or completion of the Agreement.

BID FORM

GENERAL AGREEMENTS

A. The Bidder acknowledges that he has had the opportunity to examine the site and locality where the Work is to be performed and has become familiar with the legal requirements, laws, rules, regulations and conditions affecting the cost, progress and performance of the Work; and has made such independent investigations as Bidder deemed necessary to prepare the Bid. Further, Bidder hereby states that the Base Bid set forth in this Bid Response is true and correct.

B. The Bidder agrees that this Bid shall not be withdrawn for a period of 90 calendar days After the scheduled closing time for receiving Bids.

C. The Bidder acknowledges that the price stated below includes all taxes of whatever character or description.

D. The Bidder agrees to execute a Contract for work covered by this Bid, provided that he/she be notified of its acceptance within ninety (90) days after the opening of Bids.

TIME OF COMPLETION

The undersigned agrees to commence work operations immediately upon award of the contract, with completion of the work _____ days thereafter, and that the proposed Bid is in full consideration of this.

BID FORM SUPPLEMENTS

Attached to this Bid Form and incorporated herein are the following documents, completed in full by the undersigned:

Base Bid Form Supplement – Unit Prices/Supplemental Fees

BASE BID

The undersigned Bidder, having carefully examined the Bidding and Contract Requirements, Conditions of the Contract, Drawings, Specifications, and all subsequent Addenda, all as issued by the Owner, and being familiar with all conditions and requirements of the Work, hereby proposes and agrees to furnish all material, labor, equipment, tools and supervision; and to furnish all services necessary to complete the Work required in accordance with the Bidding Documents for the following projects, in the following amount:

_____ Dollars \$ _____

(Sum to be written out)

VOLUNTARY ALTERNATIVES

The following voluntary alternatives are offered by the Bidder. The undersigned agrees that the amounts indicated below shall be added to or deducted from the Base Bid, as the case may be for each alternate which is accepted.

Description of
Voluntary Alternatives

	Add	Deduct
1.	\$	\$
2.	\$	\$
3.	\$	\$
4.	\$	\$

By: _____
(Name of bidding firm or corporation)

Witness: _____

By: _____
(Signature)

Attest: _____
(Signature)

(Type or print name)

By: _____
(Type or print name)

Title: _____
(Owner/Partner/President/Vice Pres.)

Title: _____
(Corporate Secretary or Assistant Secretary Only)

Address: _____

Phone: _____

License: _____

Federal ID No.: _____

PART VII
SUPPLEMENTAL SPECIFICATIONS

DIVISION 3 CONCRETE

SECTION 03 30 00 CAST-IN-PLACE CONCRETE

PART 1 GENERAL

1.01 REFERENCES

- A. General Conditions and Special Conditions of the Contract and Division 1 of the Specifications are a part of this Section as if stated in full herein.

1.02 WORK INCLUDED

- A. Furnish all material, equipment, transportation and facilities, and perform all labor necessary for the following:
 - 1. Cast-in-place concrete.
 - 2. Finish and curing of concrete.
 - 3. Concrete mix designs.
- B. Related Sections:
 - 1. Section 32 16 00 - Curb & Gutter, Sidewalks, and Exterior Concrete Slabs.
 - 2. Section 07 21 00 - Thermal Insulation: Perimeter Insulation.
 - 3. Section 09 67 00 - Seamless Troweled Flooring

1.03 TESTING

- A. The Contractor shall employ the services of a qualified testing agency and laboratory to perform testing of concrete as required in these Specifications.
- B. The Contractor shall give timely notice to the testing agency prior to ordering the delivery of any concrete so that the testing agency can schedule the presence of testing personnel for sampling and testing.

1.04 SUBMITTALS

- A. Submit two (2) copies of laboratory trial mix designs proposed in accordance with Method 1 ACI 301, or one (1) copy each of five (5) consecutive test results and the mix design used from a record of past performance in accordance with ACI 301 Method 2.
 - 1. Selection of Proportions: Proportions of ingredients for concrete mixes shall be determined and/or certified by an independent testing laboratory in accordance with the requirements of the ACI Standard "BUILDING CODE REQUIREMENTS FOR REINFORCED CONCRETE" (ACI 318).
 - 2. All concrete mix designs shall include the following information:
 - a. Proportions of cement, fine and coarse aggregates and water.
 - b. Water-cement ratio, design compressive strength, slump and air content.
 - c. Type of cement and aggregates.

- d. Type and dosage of all admixtures.
 - e. Special requirements for pumping.
 - f. Range of ambient temperature and humidity for which the design is valid.
 - g. Any special characteristics of the mix which require precautions in the mixing, placing, or finishing techniques to achieve the finished product specified.
3. The testing laboratory providing concrete mix designs shall be selected by the Contractor, and paid for by the Contractor.
- B. Submit manufacturer's data showing compliance with specifications for the following products:
- 1. Curing compounds
 - 2. Admixtures
- C. Submit a sample ready-mixed concrete delivery ticket in accordance with requirements of ASTM C 94.

PART 2 PRODUCTS

2.01 CONCRETE MATERIALS

- A. All materials shall be so delivered, stored and handled, as to prevent the inclusion of foreign materials and damage of materials by water or breakage. All materials shall be clean and processed from reliable sources. Contractor (or supplier in the case of using ready-mixed concrete) shall submit to the Architect a mix proportion certification for approval before placing of any concrete. Contractor shall acknowledge the requirement of the use of curing compound as specified and its availability before placing of any floor slabs.
- B. Portland Cement: Portland cement shall conform to the Standard Specifications of the ASTM C 150, Type 1, latest edition. Cement produced by the same mill shall be used throughout the project. One sack of cement shall be considered as one cubic foot of volume or 94 pounds by weight.
- C. Fine Aggregate (Sand): Fine aggregate shall consist of sand having clean, hard, durable, uncoated grains, free from deleterious substances and conforming to ASTM C 33.
- D. Coarse Aggregate: Coarse aggregate shall consist of crushed limestone, or other approved inert materials with similar characteristics having clean, hard, durable, uncoated particles, free from deleterious matter and conforming to ASTM C 33, Size 67.
- E. Mixing Water: Mixing water shall be clean and free from oil, acid, and injurious amounts of vegetable matter, alkalies, and other impurities. Preferably, City water shall be used for concrete mix.
- F. Air-Entraining Admixture: Master Builders MB-AE10 or approved equal, conforming to ASTM C 260. All exterior concrete subject to exposure shall be air-entrained. Total air content required shall be between five (5) percent and seven (7) percent.

- G. Water Reducing Admixture: Master Builders Pozzolith 322-N or approved equal containing no calcium chloride. (ASTM C 494 Type A) (See Cold Weather Requirements. For temperatures between 30 degrees and 40 degrees use Accelerating Pozzolith NC534. The use of calcium chloride in the concrete is prohibited.)

2.02 MIX PROPORTIONS

- A. Portland Cement: 5½ sacks per cubic yard (minimum) for all concrete.
- B. Pozzolith: 3 to 6 fluid ounces per 100 lbs. of cement.
- C. Water: as required not to exceed slump requirement.
- D. Strength:
 - 1. Floor Slabs: As indicated on the Drawings.
 - 2. All other concrete: 3,000 psi at 28 days.
 - 3. For curb & gutter, sidewalks and for other exterior flatwork refer to Section 32 16 00.
- E. Moisture found in aggregates shall be taken into consideration. Moisture in the aggregate shall be measured in accordance with ASTM C 566. The methods of measuring concrete aggregates shall be such that the proportions can be accurately controlled and easily checked at any time during the work. Measurements and materials for ready mixed concrete shall conform with the Standard Specifications of the ASTM C 94, latest edition.

2.03 WORKABILITY

- A. The mixture shall produce a concrete that can be worked readily into corners and angles of forms and around reinforcement without excessive spading or separation of materials. In no case shall more than one part of fine aggregate be used to one part of coarse aggregate nor shall amount of coarse aggregate be such as to produce harshness in placing, or honeycombing in the structure. The standard slump test (ASTM C 143) shall be used to check the workability of each batch of concrete. The maximum slump allowable shall be as indicated on the Drawings. The maximum slump allowable for pavement shall be 4 inches. The Architect may allow or order variations from this amount as required by specific conditions of the job.

2.04 MIXING

- A. Concrete shall be mixed in a truck mixer until there is a uniform distribution of materials. The entire contents of the drum shall be discharged before recharging. The volume of the mixed material per batch shall not exceed the manufacturer's rated capacity of the mixer. The mixer shall be operated at not greater than twenty r.p.m. Mixing shall continue for at least one and one-half minutes after all the ingredients are in the mixer. The delivery ticket for each load of concrete shall state the proportions of each material in the mix for that load.
- B. Concrete transported in a truck mixer, agitator, or other transportation device, shall be discharged at the job and placed in its final position in the forms within one and one-half hours after the

introduction of the mixing water to the cement and aggregate, or the cement to the aggregate, except that in hot weather or under other conditions contributing to quick stiffening of the concrete, the maximum allowable time may be reduced by the Architect.

- C. Retempering of concrete which has partially hardened, that is, remixing with or without additional aggregate, cement or water, will not be permitted.

2.05 REINFORCEMENT

- A. Reinforcing steel shall be manufactured from new billet steel of 60,000 psi yield strength and shall conform to ASTM A 615. Wire mesh fabric shall conform to ASTM A 185.

2.06 FORMS

- A. Forms shall be true and rigid and built to line, shape and grade shown on the plans. They shall be made of sound and reasonably smooth lumber, plywood, or steel. Joints shall be mortar tight and forms shall be tied and braced to prevent any bulging or deflection during concreting. Cut cleanouts at bottom as required for removal of sawdust and debris.
 1. Plywood: PS 1, sound, undamaged sheets with straight edges.
 2. Lumber: Construction grade.
 3. Steel: Minimum 16 gage sheet, well matched, tight fitting, stiffened to support weight of concrete without deflection detrimental to tolerances and appearance of finished surfaces.
 4. Carton Forms: Moisture resistant treated paper faces, biodegradable, structurally sufficient to support weight of wet concrete until initial set.
 5. Form Release Agent: Colorless mineral oil which will not stain concrete.
- B. All form ties shall have $\frac{3}{4}$ " cones with 1" break-back.
- C. Before reusing forms, or when using second-hand lumber for forms, they shall be cleaned and all nails removed therefrom. Immediately before erecting formwork, all forms shall be thoroughly cleaned of all dirt, debris and foreign matter, and a light coating of form release agent applied.
- D. Box out for all slots, chases, recesses or openings as shown on the Drawings and as required by the work of all other trades. Box out for all temporary openings such as pipe spaces, and build forms to seal up when and as required.
- E. Design, engineer, and construct forms, shores, bracing, and other temporary supports to support loads imposed during construction, in accordance with ACI 347. Design under the direct supervision of a licensed Professional Engineer experienced in design of this work.

2.07 INSULATION

- A. Refer to Section 07 21 00.

2.08 VAPOR BARRIER UNDER SLAB-ON-GRADE

- A. 10 mil thick polyethylene film, clear or black, with 12 inch minimum lap at adjoining edges.

2.09 WATERSTOP

- A. Ribbed PVC with center bulb as manufactured by Vinylex Corporation; Knoxville, TN (423) 690-2211, Greenstreak, St. Louis, MO (314) 225-9400, or BoMetals, Inc., Powder Springs, GA (770) 439-8577.
- B. Profile: 4 inch width, ribbed, with center bulb.

2.10 EPOXY BONDING AGENT (ASTM C 881)

- A. Concessive Liquid (LPL) by Master Builders Technologies; San Carlos, California (800) 227-8464.
- B. EVA-POX Epoxy Paste No. 22 by E-poxy Industries, Inc.; Ravena, New York (800) 833-3400.
- C. Uniweld by Permagine Industries, Inc.; Plainview, New York (800) 645-7546.
- D. Substitutions: Similar product by other manufacturers. Submit name, compressive strength and tensile strength for acceptance.

2.11 PREMOLDED JOINT FILLER

- A. Non-extruding resilient type conforming to ASTM D 1752, Type I or Type III. For sealant and backer material over premolded joint filler refer to Section 07 92 00.

2.12 CHEMICAL CURE FOR SLABS

- A. Non-residual dissipating curing compound designed and certified to meet ASTM 309:?

2.13 MOISTURE CURE

- A. Water: Potable.
- B. Moisture-retaining Coverings: Burlap, cotton mats, or other moisture-retaining fabrics; AASHTO M 182, ASTM C 171, or AASHTO M 73. Provide burlap free of sizing. Rinse thoroughly in caustic soda to remove soluble substances and make burlap more absorbent.

PART 3 EXECUTION

3.01 EXAMINATION

- A. Verify anchors, seats, plates, reinforcement, precast catch basins, floor drains and other items to be cast into concrete are accurately placed, held securely, and will not cause hardship in placing concrete.
- B. Refer to Drawings showing plumbing for location of precast catch basins and floor drains.

3.02 PREPARATION

- A. Prepare previously placed concrete by cleaning with steel brush and applying bonding agent. Apply bonding agent in accordance with manufacturer's instructions. Do not apply bonding agent at slab-on-grade construction joints.

3.03 PLACING REINFORCEMENT

- A. Reinforcing bars shall be accurately placed and securely tied with No. 18 iron wire at all intersections. Bars and mesh shall be supported above subgrade on precast concrete blocks and above forms on steel chairs and spacers. Metal hangers shall be used for support of vertical reinforcing. Metal chairs, which are in contact with the exterior surface of the concrete, shall be galvanized. Layers of bars shall be separated by supporting bars with wire from formwork. The use of pebbles, pieces of broken stone or brick, metal pipe and wood blocks for support of bars shall not be permitted.
- B. Splicing and laps shall be as shown on Drawings.
- C. In slabs on grade and elevated slabs, position welded wire fabric or reinforcement bar 2" above bottom of slab. During concrete placement operations, assign one man to keep fabric properly positioned and during this time "he shall do nothing else". Reinforce such slabs with wire mesh fabric of the sizes indicated on the Drawings. For all exterior stoops, walks, curbs, and exterior slabs, refer to Drawings.
- D. All reinforcement shall be unpainted, uncoated, clean and free of rust or scale before being placed.
- E. Placement of reinforcing shall be approved by the Architect and/or Engineer before concrete is placed.

3.04 PREPARATION FOR PLACING CONCRETE

- A. Preparation: Equipment for chuting, pumping, and pneumatically conveying concrete shall be of such size and design as to assure a practically continuous flow of concrete at the delivery end without separation of the materials, and all of the details thereof shall be submitted to Architect for approval in advance of the use of such equipment. The use of gravity-flow or aluminum chutes or conveyors for transporting concrete horizontally will not be permitted. Where placing of structural

concrete by pumping methods are required comply with ACI 304.2R "Placing Concrete By Pumping Methods".

- B. Inserts: Give the various trades and subcontractors ample notification and opportunity to install anchors, nailers, pipes, conduits, boxes, stair nosings, pipe bollards, inserts, thimbles, sleeves, frames, vents, wires, supports, or other items required to be built into the concrete by the provisions of the Drawings or of the Specifications governing the work of such trades and subcontractors, or as may be necessary for the proper execution of their work. Obtain suitable templates or instruction for the installation of such items as are not required to be actually placed in the forms by the affected trades or subcontractors themselves.
- C. Contractor shall provide access for delivery and provide sufficient equipment and manpower to rapidly place all concrete.
 - 1. All work shall be in accordance with ACI 304-83 "Recommended Practice for Measuring, Mixing, Transporting, and Placing Concrete".
 - 2. Formwork shall have been completed; snow, ice, water, and debris shall have been removed from within forms.
 - 3. Expansion joint material, anchors, and all embedded items shall have been positioned.
 - 4. Subgrades shall be sprinkled sufficiently to eliminate water loss from the concrete.

3.05 DEPOSITING CONCRETE

- A. General: Place concrete in reasonably uniform layers, approximately horizontal, 12 to 18 inches thick exercising care to avoid vertical joints or inclined planes. The piling up of concrete in the forms, in such manner as to cause the separation or loss of any of its ingredients, will not be permitted. Concrete which has partially set or hardened shall not, under any circumstances, be deposited in the work. Place concrete in the forms as nearly in its final position as is practical to avoid rehandling. Exercise special care to prevent splashing the forms or reinforcement with concrete. Remove any hardened or partially hardened concrete which has accumulated on the forms or reinforcement before the work proceeds. Do not place concrete on previously deposited concrete which has hardened sufficiently to cause the formation of seams or planes of weakness within the respective member or section, except as hereinafter specified. Do not permit concrete to drop freely any distance greater than four feet (4'-0"). Where longer drops are necessary use a chute, tremie, or other approved conveyance to assist the concrete into place without separation. Do not place directly into any excavations where water is standing. If the place of deposit cannot be successfully pumped dry, place through a tremie with its outlet end near the bottom of the place of deposit.
- B. Slump: Concrete shall not be placed when its plasticity, as measured by slump test, is outside the limits shown on the Drawings.
- C. Vibration: As soon as concrete is deposited, thoroughly agitate the same by means of mechanical vibrators and suitable hand tools, so manipulated as to work the mixture well into all parts and corners of the forms, and entirely around the reinforcement and inserts. Mechanical vibrators shall have a minimum frequency of 7000 revolutions per minute and shall be operated by competent workmen. Over-vibrating and use of vibrators to transport concrete within forms shall not be

allowed. Vibrators shall be inserted and withdrawn at many points, from 18 to 30 inches apart. At each insertion, the duration shall be sufficient to consolidate the concrete but not sufficient to cause segregation, generally from 5 to 15 seconds duration. A spare vibrator shall be kept on the job site during all concrete placing operations. Do not insert vibrator into lower courses that have begun to set. Avoid placing vibrator in contact with reinforcing steel.

- D. Concrete shall not be placed on frozen ground.
- E. Thoroughly wet all forms and contact surfaces before placing concrete. For pavement the base shall be thoroughly wetted prior to placing concrete and kept moist at all times during the placing operation. If a situation arises such that the base is allowed to dry out, it shall be rewetted before placement is allowed to continue.
- F. Conveying Concrete: Convey concrete from the mixer to the place of final deposit by methods which will prevent the separation or loss of the ingredients. Concrete to be conveyed by pumping will require approval of Architect for each class of concrete specified before being used.
- G. Ensure reinforcement, inserts, embedded parts and formed joints are not disturbed during the depositing of concrete.

3.06 FINISHING

- A. For all surfaces covered in final construction or below grade, the ties shall be broken off and all voids shall be grouted.
- B. For vertical surfaces exposed to view all ties shall be broken off, all voids grouted, all fins, joints, ridges, and form defects carefully removed. Surfaces shall be rubbed with cement or abrasive bricks and water within 24 hours after removal of forms, and a general uniform appearance attained.
- C. Interior slabs shall be floated to a uniform level surface with a uniform slope to drains, as shown on the Drawings. Final finish for building floors shall be hard steel trowel finish giving a hard, dense, smooth surface. If sufficient fines cannot be worked up from base slab, the Contractor may apply a dry mix of cement and sand passing a No. 16 sieve and mixed in the ratio of 1:2½ by volume. Compact and work surface mix into base course. The surface mix shall never be added as a "drier" to absorb excess surface water.
- D. Monolithic Slab Finishes:
 - 1. Trowel Finish: Apply trowel finish to monolithic slab surfaces to be exposed to view and surfaces to be covered with resilient flooring, carpet, thin set ceramic tile, paint, or other thin film finish coating system.
 - a. After floating, begin first trowel finish operation using power-driven trowel. Begin final troweling when surface produces a ringing sound as trowel is moved over surface. Consolidate concrete surface by final hand-troweling operation, free of trowel marks,

uniform in texture and appearance, and with surface leveled to tolerances of Ff 20 - Ff 17.

2. Nonslip Broom Finish: Apply nonslip broom finish to exterior concrete sidewalks, stairs, landings, ramps, and elsewhere as indicated.
 - a. Immediately after light steel trowel finishing, slightly roughen concrete surface by brooming with fiber-bristle broom perpendicular to main traffic route. Coordinate required final finish with Architect before application.
- E. As soon as floor will bear weight after final troweling, sweep clean of any dirt and soil.
 1. Apply two (2) coats of chemical curing compound in strict accordance with manufacturer's instructions.
 2. Preferred cure for floors in lieu of chemical cure is moisture cure. Cover floor with burlap or cotton mats and maintain continuously moist by misting spray for a minimum of seven days after concrete is placed.

3.07 CURING AND REMOVAL OF FORMS

- A. After placement, exposed concrete not covered by forms shall be moist cured. After forms are removed, exposed concrete surfaces shall be moist cured for an additional time to total seven (7) days since the placement of the concrete.
- B. Concrete shall be cured at a temperature within the range of 50°F., to 100°F. For cold weather and hot weather requirements, see articles so titled below.
- C. Forms shall remain undisturbed until the concrete has gained sufficient strength to sustain its own weight and any temporary or permanent load that may be placed on it during the building of the structure. For pavement, forms may be removed as soon as the concrete has hardened sufficiently to resist damage from removal operations, but not sooner than 24 hours from cessation of concrete placement. In no case shall forms for other concrete items be removed in less than three (3) days after placing concrete.

3.08 REQUIREMENTS FOR COLD WEATHER

- A. No concrete shall be placed on iced or frozen subgrade. No concreting will be permitted in temperatures below 32°F. Do not use frozen materials containing ice or snow. Ascertain that forms, reinforcing steel, and adjacent concrete surfaces are entirely free of frost, snow, and ice and temperature of these materials is above 32°F before placing concrete.
- B. Comply with the following for minimum temperature of concrete delivered to jobsite:
 1. Air temperature 32-45°F: Concrete temperature 60°F minimum.
 2. Maximum concrete temperature: Not to exceed the minimum required temperature by more than 10°F.
- C. Combine water heated to above 100°F with aggregates before cement is added. Do not add cement to water or aggregates having temperature greater than 100°F.

- D. When temperatures of 40°F or lower occur during the placing and curing of concrete, maintain temperature of concrete at not less than 55°F for at least three (3) days.
 - 1. Make arrangements before placement to maintain required temperature without damage from excessive heat.
 - 2. Do not use combustion heaters during first 48 hours without precautions to prevent exposure of concrete to exhaust gases containing carbon dioxide and carbon monoxide.
 - 3. Provide temporary housings or coverings including tarpaulins or plastic film. Keep protection in place and intact at least 24 hours after artificial heat is discontinued.
 - 4. Avoid rapid dry-out of concrete due to overheating, and avoid thermal shock due to sudden cooling or heating.
- E. Protect concrete work from physical damage or reduced strength which could be caused by frost, freezing actions, or low temperatures, in compliance with the requirements of ACI 306R and as herein specified.
- F. No admixtures shall be used except with approval of the Architect. For temperatures between 32°F and 40°F, use Master Builders Accelerating Pozzolite NC 534.
 - 1. Mix proportions shall be as follows:
 - a. 32-40°F 24-32 oz. per 100 lbs. of cement
- G. The use of salts, chemicals, or other foreign materials in the concrete mix to lower the freezing point is prohibited.

3.09 REQUIREMENTS FOR HOT WEATHER

- A. When hot weather conditions exist that would seriously impair the quality and strength of concrete, place concrete in compliance with ACI 305R and as herein specified.
- B. Temperature of concrete at time of placing: Not to exceed 90°F. Maintain an accurate reading thermometer at the job site to check temperature of concrete. Reject concrete before placing if temperature of concrete exceeds 90°F.
- C. Execute special precautions to protect fresh concrete before and during finishing when the rate of evaporation of surface moisture from concrete exceeds 0.2 pounds per square foot per hour. Determine rate of evaporation in accordance with ACI 305R. Provide special precautions as required:
 - 1. Cool ingredients before mixing to reduce concrete temperature at time of placement. Mixing water may be chilled, or chopped ice may be used to control the temperature provided the water equivalent of the ice is calculated to the total amount of mixing water.
 - 2. Dampen subgrade and forms.
 - 3. Cover reinforcing steel with water-soaked burlap so the steel temperature will not exceed the ambient air temperature immediately before embedment in concrete.

3.10 EXTERIOR AND INTERIOR CONTROL JOINTS

- A. Saw concrete slab immediately after trowel finish. Saw joints shall be 1/5 of the total slab thickness in depth for building floor slabs.
- B. Joints for slabs shall be where shown on Drawings.

3.11 TESTING

- A. Testing shall include unconfined compression test of molded concrete cylinders, slump tests, air content tests (where air-entrainment is required) and fresh concrete temperature tests.
 - 1. Testing for Building: Concrete shall be sampled, cured and tested for compressive strength in accordance with ASTM C 31, ASTM C 39 AND ASTM C 172. Compressive tests shall be prepared in sets of three (3) cylinders for each test. Specimens for each set shall be obtained at regularly spaced intervals during discharge of the middle half of a load from a stationary mixer or truck. A minimum of one (1) set shall be taken for each 1000 square feet of surface for slabs or walls. Not less than one (1) set shall be taken per 40 cubic yards of concrete nor less than one (1) set shall be taken for each foundation or structure except when placing a number of items each smaller than 10 cubic yards, in this case one (1) set per 10 cubic yards shall suffice.
 - 2. All cylinders must be immediately stored adjacent to pour under similar atmospheric conditions, under wet sand, burlap, or polyethylene for approximately 24 hours after preparation. Avoid any impact during this time period.
 - a. After initial storage the cylinders (still in their molds) shall be packed in sealed polyethylene bags, wet sand or other resilient materials and delivered to the testing laboratory.
 - b. The testing laboratory shall moist-cure the cylinders until they are tested.
 - 3. Test for Slump, Air Content and Temperature:
 - a. Slump test shall be taken for each set of test cylinders as well as from each load from a stationary mixer or truck to test consistency of concrete. Tests shall be in accordance with ASTM C 143 and ASTM C 172.
 - b. The acceptance test for air content of air-entrained concrete shall be made regularly in accordance with ASTM C 173.
 - c. The temperature of the fresh concrete from each set of cylinders shall be recorded.
 - 4. Test Cylinder Identification: Test cylinder sets shall be dated and numbered consecutively. Each cylinder of each set shall be given an identifying letter (A, B, C). In areas such as floor slabs and foundations, a sketch shall be prepared to identify pour locations. The following data shall be recorded to the cylinder mold at the time the cylinders are prepared and shall be included in the test report:
 - a. Test cylinder number and letter.
 - b. All foundations or structures covered by this test.
 - c. Proportions of concrete mix or mix identification.
 - d. Maximum size coarse aggregate.
 - e. Specified compressive strength.

- f. Slump, air content (where applicable) and fresh concrete temperature.
 - g. Date placed and time placed.
 - h. Ambient temperature at time of placement
 - i. Name of inspector making cylinders.
5. Test Cylinder Results: Specimens shall be tested in accordance with Standard Method of Test for Compressive Strength of Molded Concrete Cylinders (ASTM C 39).
- a. Cylinder A at seven (7) days. The result should be at least 60% of the specified 28 day compressive strength.
 - b. Cylinder B at 28 days.
 - c. Cylinder C shall not be tested but shall be kept in reserve for possible testing at a later date, not to exceed 60 days.
 - d. A report of test results shall be furnished directly to the Architect/Engineer.

END OF SECTION

DIVISION 4 MASONRY

SECTION 04 05 00 MORTAR AND GROUT FOR MASONRY

PART 1 GENERAL

1.01 REFERENCES

- A. General Conditions and Special Conditions of the Contract and Division 1 of the Specifications are a part of this Section as if stated in full herein.
- B. American Society for Testing and Materials (ASTM):
 - 1. ASTM C 91 - Specification for Masonry Cement.
 - 2. ASTM C 94 - Specification for Ready-Mixed Concrete.
 - 3. ASTM C 109 - Test Method for Compressive Strength of Hydraulic Cement Mortars.
 - 4. ASTM C 143 - Test Method for Slump of Hydraulic Cement Concrete.
 - 5. ASTM C 144 - Specification for Aggregate for Masonry Mortar.
 - 6. ASTM C 150 - Specification for Portland Cement.
 - 7. ASTM C 207 - Specification for Hydrated Lime for Masonry Purposes.
 - 8. ASTM C 270 - Specification for Mortar for Unit Masonry.
 - 9. ASTM C 387 - Specification for Packaged, Dry, Combined Materials for Mortar and Concrete.
 - 10. ASTM C 404 - Specification for Aggregates for Masonry Grout.
 - 11. ASTM C 476 - Specification for Grout for Masonry.
 - 12. ASTM C 1019 - Method of Sampling and Testing Grout.
 - 13. ASTM C 1142 - Specification for Ready Mixed Mortar for Unit Masonry (Prohibited).
- C. IMIAC - International Masonry Industry All-Weather Council: Recommended Practices and Guide Specifications for Cold Weather Masonry Construction.

1.02 SUMMARY

- A. Section Includes: Mortar and grout for unit masonry.
- B. Related Sections:
 - 1. Section 04 22 00 - Concrete Masonry Units: Installation of mortar and grout, reinforcement and anchorages.
 - 2. Section 04 22 23 - Architectural Concrete Masonry Units: Installation of mortar and grout, reinforcement and anchorages.
 - 3. Section 04 72 00 - Manufactured Stone Veneer: Installation of mortar and grout.

1.03 TESTING

- A. The Contractor shall employ the services of a qualified testing agency and laboratory to perform testing of mortar and grout.
- B. The Contractor shall give timely notice to the testing agency prior to the start of masonry work and during the progress of masonry work so that test specimens can be made and tested to adequately control the quality of the work.

1.04 QUALITY ASSURANCE

- A. Testing CMU Grout:
 - 1. Determine and certify that proportions of ingredients for mix design will provide the specified compressive strength for each type of grout.
 - 2. Test mix design prior to beginning construction of CMU walls. Test grout during construction of CMU walls 16 feet high, or higher, at the rate of one test for each 5000 square feet of wall. Test in accordance with ASTM C 1019.
- B. Mortar:
 - 1. Determine and certify that proportions of ingredients for mix design in accordance with ASTM C 270 will provide the specified strength.
 - 2. Test mortar during construction of CMU walls 16 feet high, or higher, at the rate of one test for each 5000 square feet of wall. Test mortar in accordance with ASTM C 109.

1.05 SUBMITTALS

- A. Submit mix proportions for grout and test data indicating mix meets the minimum strength required at 28 days.

1.06 DELIVERY, STORAGE AND HANDLING

- A. Store sand for mortar on plastic sheeting to prevent contamination by extraneous chemical in earth beneath.

1.07 PROJECT CONDITIONS

- A. Environmental Requirements:
 - 1. Cold Weather Requirements: IMIAC - Recommended Practices and Guide Specifications for Cold Weather Masonry Construction.
 - 2. Specific Cold Weather Requirements: When the ambient air temperature is below 40 degrees F, heat mixing water to maintain mortar temperature between 40 degrees F and 120 degrees F until placed. When the ambient air temperature is below 32 degrees F, heat the sand and water to maintain this mortar temperature.
- B. For other measures and hot weather requirements refer to Section 04 21 00 and Section 04 22 00.

PART 2 PRODUCTS

2.01 MATERIALS

- A. Portland Cement: ASTM C 150, normal-Type I or Type II; gray color. Fly ash, slag and pozzolans are not permitted as substitutes for Portland Cement.
- B. Mortar Aggregate: ASTM C 144, standard masonry type; clean, dry, protected against dampness, freezing, and foreign matter.
- C. Grout Aggregate: ASTM C 404; use of blast furnace slag is not permitted. Maximum coarse aggregate size, 3/8 inch.
- D. Calcium chloride is not permitted in mortar or grout. Admixtures or other chemicals containing Thiocyanates, Calcium Chloride or more than 0.1 percent chloride ions are not permitted.
- E. Hydrated Lime: ASTM C 207, Type S.
- F. Quicklime: ASTM C 5, pulverized to pass a #20 mesh sieve.
- G. Water: Potable.
- H. Water repellent admixture at single wythe Architectural concrete masonry unit construction (Compatible with block manufacturer admixture).
- I. Other Admixtures: Not permitted unless approved by the Architect prior to construction.

2.02 MIXES - MORTAR

- A. Mortar: Type S for general use in accordance with the Proportion specification of ASTM C 270.

1. Mortar Proportions:

Proportions by Volume			
Mortar Type	Portland Cement	Hydrated Lime or Lime Putty	Damp Loose Aggregate
S	1	½	2¼ to 3 times sum of volumes of cements and lime used

- 2. Mixing of components on-site is acceptable.
- 3. Mixing on-site water and packaged dry blended mix for mortar (ASTM C 387) is acceptable.
- 4. Use of ready mix mortar (ASTM C 1142) is prohibited.

- B. Pointing Mortar: Duplicate original mortar proportions. Add aluminum tristearate, calcium stearate, or ammonium stearate equal to 2% of Portland cement weight.
- C. Mortar Color: Control mortar mix to determine desired gray tone color. No additives.

2.03 MIXING - MORTAR

- A. Thoroughly mix mortar ingredients in accordance with ASTM C 270, in quantities needed for immediate use.
 - 1. Maintain sand uniformly damp immediately before the mixing process.
 - 2. Slake lime according to manufacturer's directions and allow to become cold before using.
 - 3. Provide uniformity of mix and coloration.
 - 4. Do not use anti-freeze compounds.
 - 5. If water is lost by evaporation, retemper only within 2 hours of mixing. Do not retemper mortar more than 2 hours after mixing.

2.04 MIXES - GROUT FILL

- A. Grout fill is for concrete masonry unit bond beams, lintels, and reinforced cells with reinforcing bars and embedded plates.
 - 1. Compressive Strength: 2500 psi minimum at 28 days, as determined in accordance with the provisions of ASTM C 1019.
 - 2. Slump: 8 inches, minimum; 10 inches, maximum, taken in accordance with ASTM C 143.
 - 3. Use coarse grout when grout space is equal to or greater than 4 inches in both directions.
 - 4. Use fine grout when grout space is smaller than 4 inches in either direction.
 - 5. Do not use air-entrainment admixtures.

2.05 MIXING - GROUT

- A. Grout: Batch and mix grout in accordance with ASTM C 94 or ASTM C 476 for site batched and mixed grout. Do not use anti-freeze compounds to lower the freezing point of grout.

PART 3 EXECUTION

3.01 INSTALLATION

- A. After reinforcing of masonry is securely tied in place, plug cleanout holes with masonry units. Brace against wet grout pressure.
- B. Install mortar and grout under provisions of Section 04 22 00.

END OF SECTION

DIVISION 4 MASONRY

SECTION 04 09 60 CONCRETE MASONRY UNIT DRAINAGE SYTEM

PART 1 GENERAL

1.01 REFERENCES

- A. Drawings and general provisions of the Contract, including General and Supplementary Conditions and Division 1 Specification Sections, apply to this Section.
- B. National Concrete Masonry Association (NCMA) TEK Notes.

1.02 SUMMARY

- A. Furnish and install Concrete Masonry Unit Drainage System at all exterior single-wythe Masonry Walls.

1.03 SUBMITTALS

- A. Product Data: Catalog cuts, installation details and specifications for all materials.
- B. Samples: Of drainage strip, standard sample length and one vertical mesh sleeve.

1.04 QUALITY ASSURANCE

- A. MockUP:
 - 1. Build drainage strip and vertical mesh sleeve into sample panel of masonry wall as specified in Section. Unit Masonry and as specified herein.
 - 2. Obtain approval prior to proceeding with any masonry work.
- B. Pre-Installation Conference: Convene prior to commencing work of this Section.

PART 2 PRODUCTS

2.01 MATERIALS

- A. #BN120 CMU Drainage System as manufactured by Mortar Net, Inc., Gary IN. (Ph: 1-800-664-6638)
- B. Components:
 - 1. Drainage Strip: #BN 121, 28 gauge stainless steel, 4 inch wide by 60 inches long with formed drip on the face edge and drainage mesh factory attached.
 - 2. Vertical Mesh Sleeve: #BN 122, 7 x 7 x 3/8 inch thick polyester mesh.
 - 3. Sealant: One part silicone as approved by system manufacturer.

PART 3 EXECUTION

3.01 EXAMINATION

- A. Verify items provided by other Sections of work are properly located.

3.02 INSTALLATION

- A. Place first drainage strip in place so that strip edge break is positioned in alignment with outside edge of CMU face (or foundation wall). Position back edge of drainage strip slightly in front of reinforcing bar as applicable. Use sealant to temporarily anchor drainage strip during positioning.
- B. Place three beads of sealant approximately 1 inch apart running from front to back on unmeshed 4 inch portion of the positioned drainage strip.
- C. Install another drainage strip overlapping caulked area of previously placed one. Position with drip edges in alignment and such, that caulked, un meshed area of previously installed drainage strip is completely covered without overlapping onto the meshed area. A thin strip of exposed, unmeshed drainage strip is acceptable to avoid overlapping the meshed area.
- D. Place three beads of sealant on the un meshed portion of the just placed drainage strip and install the next one.
- E. Continue as specified above to form continuous drainage strip system along entire perimeter of wall.
- F. Second CMU Course: Install one vertical mesh sleeve in each core. Install against inside face of outside shell to form U-shape sleeve.
- G. Drainage system over doors, windows and along bond beams; Properly dam ends of drainage strips.

3.03 PROTECTION

- A. Provide protection without damaging completed work.

END OF SECTION

DIVISION 4 MASONRY

SECTION 04 22 00 CONCRETE MASONRY UNITS

PART 1 GENERAL

1.01 REFERENCES

- A. General Conditions and Special Conditions of the Contract and Division 1 of the Specifications are a part of this Section as if stated in full herein.

1.02 SUMMARY

- A. Provide concrete masonry units (CMU), in place, with reinforcing, flashing, control joints, and other accessories for structurally sound walls and partitions.

1.03 TESTING

- A. The Contractor shall employ the services of a qualified testing agency and laboratory to perform testing of masonry as required in these Specifications.
- B. The Contractor shall give timely notice to the testing agency prior to the start of masonry work and during the progress of masonry work so that prisms can be made and tested to adequately control the quality of the work.

1.04 SAMPLE WALL

- A. At starting of masonry work, build a sample section of CMU wall, including veneer where applicable, approximately 4 x 8 feet, representative of the proposed method of laying and workmanship and secure Architect's approval before proceeding with the remaining work. Sample wall section may become part of finished walls, if approved. Build additional samples if required.

1.05 DELIVERY, STORAGE, AND HANDLING

- A. Deliver and store on the site, CMU, sufficient in quantity for the entire job, and secure approval by Architect before placing any of same in the work.
- B. Store CMU on pallets above grade.
- C. Handle and transport CMU using methods that will protect them from damage. Replace any damaged units at no cost to the Owner.

PART 2 PRODUCTS

2.01 LIGHTWEIGHT CONCRETE MASONRY UNITS

- A. Units shall be made with Haydite aggregate and conform to the following:
 - 1. ASTM C 90 Hollow Load-Bearing Concrete Masonry Units, Type 1, Grade N-1.

2. Maximum linear shrinkage 0.025% as measured by ASTM C 426.
 3. Maximum moisture content at delivery reduced to 30% of total absorption as measured by ASTM C 140. Plant-cure units a minimum of 28 days before delivery.
 4. Sizes: Nominal 8" x 16" face, two-cell units of 4", 6", 8" or 12" thickness as indicated, with half units, square-end corner units, solid units, jamb units, brick units, header units, bond beam lintel units, bullnose units, pilaster units, and other units necessary to maintain the bond and as otherwise indicated.
- B. Lightweight concrete masonry units shall be as manufactured by Joplin Building Materials, Joplin, Missouri, or approved equal, approved seven (7) days before bidding.
 - C. Concrete masonry units, required to be in fire rated walls, as indicated on the Drawings, shall be certified by a recognized testing agency to have the required time-design fire resistance rating.
 - D. Perform prism testing in accordance with Article 3.05. Average compressive strength of 3 prisms shall not be less than 2000 psi.

2.02 DECORATIVE CAST STONE

- A. Cast stone shall be Accent Cast Stone as manufactured by Joplin Building Materials.
- B. Units shall be of the dimensions and design indicated on the Drawings. Color shall be as selected by Architect.

2.03 REINFORCEMENT (BLOCK MESH)

- A. Single Wythe Exterior Walls: Dur-O-Wal extra heavy truss design, 3/16" side rods and No. 9 cross rods, wall reinforcing, of proper size and shape as required for wall thickness as shown on the Drawings. All walls shall have reinforcing at 16" o.c. vertically. Stacked bond load bearing walls shall have in addition, reinforcing at 8" o.c. in the top three courses.
- B. Single Wythe Interior Walls: Dur-O-Wal Standard truss design, or approved equal, No. 9 side and cross rods, masonry wall reinforcing, of proper size and shape as required for wall thickness as shown on the Drawings. All walls shall have reinforcing 16" o.c. vertically. Stacked bond load bearing walls shall have in addition, reinforcing at 8" o.c. in the top three courses.
- C. Double Wythe Walls: Dur-O-Wal extra heavy truss design, 3/16" side rods and No. 9 cross rods, of sufficient width for both wythes plus cavity between wythes. Cross rods shall have a vee-drip located in the cavity. For exterior double wythe walls, reinforcement shall be hot-dipped galvanized in accordance with ASTM A 153, Class B-2.
- D. Provide corresponding prefabricated corner and tee reinforcement at all corners and intersections.

2.04 REINFORCEMENT (BARS)

- A. ASTM A 615, Grade 60.

2.05 CONCEALED FLASHING

- A. Concealed flashing, where indicated on Drawings, shall be TAMKO TW THRU-WALL flashing, 40 mil (0.040") as manufactured by Tamko Roofing Products, or approved equal.

2.06 CAVITY WALL INSULATION

- A. Insulation boards shall be extruded polystyrene board, 2 inch thickness, 16 inches wide.
 - 1. Aged R-value: 5.0 per inch in accordance with ASTM C 518.
 - 2. Water Vapor Permeance: 0.4 - 1.1 perms in accordance with ASTM E 96.

PART 3 EXECUTION

3.01 EXAMINATION

- A. Examine areas, preparatory work, and conditions under which work of this Section will be performed. Correct any unsatisfactory conditions. Do not proceed with masonry work until unsatisfactory conditions have been corrected.
- B. Beginning masonry work indicates acceptance of existing conditions.

3.02 INSTALLATION

- A. Lay no units having a film of water or frost on their surfaces.
- B. Lay no masonry when temperature is below 45 degrees F, unless it is rising, and at no time when below 40 degrees F, without Architect's permission. Such permission shall not relieve the Contractor from responsibility for the work, however. If permitted to work below 40 degrees F, make provisions to heat and dry materials and protect work from freezing.
- C. Build in bolts, ties, other metal anchors, sleeves, miscellaneous metals, and wood nailing strips as necessary to secure masonry together or to other materials. Use no continuous wood nailing strips.
- D. Build in steel lintels, bearing plates and flashings in contact with masonry. Bed flashings in mortar.
- E. Close up any recesses after pipes, ducts, conduits and other items are in and have been inspected by Architect and/or other proper authorities and do all patching after other trades have completed their work. Special attention shall be taken in closing all voids at cuts for outlet boxes, plumbing rough-ins, cleanouts, or other temporary openings.
- F. Cut exposed masonry with masonry saw to produce clean-cut edges. Other than water used in cutting operations, allow no wetting of blocks prior to laying.

- G. Provide insulation boards between concrete block wall and brick at exterior wall as indicated on the Drawings. Install insulation in as great a length as possible, minimizing end joints. Fill all joints tight and tape covered. Tape as recommended by the manufacturer.
- H. At end of each work day or shut down period, cover walls with strong waterproof membrane overlapping walls 12 inches minimum on each side and securely anchor in place.
- I. Use a full height story pole at all corners. Level first and frequent courses with instrument.
- J. Build in door and window frames and their anchors. Slush steel door frame jambs and heads full of grout. Slush cells full of mortar where excessive cutting for conduit or other devices has weakened masonry.
- K. Where fresh masonry adjoins previously set masonry, clean, roughen and lightly wet the set masonry before joining with new. Where stop-offs are necessary in horizontal runs, rake back the masonry; toothing not permitted unless approved by Architect.
- L. Build walls and partitions to dimensions indicated, in courses 8" high in running bond with units stacked one over the other with vertical joints offset, at the locations indicated on the Drawings.
- M. Reinforce walls and partitions with block mesh using appropriate types indicated above and in nominal width of wall or partition. Unless indicated otherwise, place a layer immediately above and below openings and elsewhere in every second course, with ends lapped 6" and alternately staggered. Bond corners and intersections with prefabricated corner and partition units.
- N. Set reinforcing bars in bond beam lintel units and shear walls. Position bars as indicated, fill cavity with grout and puddle to effect good contact with steel and block. Finished lintel must bear 8" minimum at each jamb.
- O. Install all special shapes as indicated on Drawings or as required.
- P. Where partitions abut exterior walls, rake out continuous vertical joint 3/8" x 1" to receive caulking by other trades, as specified in Section 07 92 00.
- Q. Where room finish schedule indicates that rooms have no base (none) bedding mortar joint shall be pressed tight and flush to the face of the block.

3.03 JOINTS

- A. Set in mortar joints 3/8" thick with full coverage on vertical and horizontal face shells.
- B. Except as noted, after mortar has begun to set, compact with tool to form concave joints where such joints will be exposed. Where concealed behind gypsum board or other finishes, compact joints smooth and flush. Brush excessive mortar from edges. After mortar has set, buff any remaining protruding mortar from joints.

3.04 POINTING AND CLEANING

- A. At building completion, when roofing work and heating system is operational or at such other time as Architect may direct, point up all exposed masonry, fill all holes and joints; remove loose mortar, cut out defective joints, repair cracks and defects, and repoint where necessary. Thoroughly clean masonry surfaces to be exposed, painted or unpainted.
- B. After walls have been "topped-out" and allowed to dry a minimum of seven (7) days, clean split-face veneer units along with face brick surfaces with cleaner; the specific formulation of cleaning agent to be determined by consultation between cleaner manufacturer and masonry manufacturer, based on the final masonry selection and the installation conditions. Apply cleaning agent and rinse per manufacturer's directions and as hereinafter specified. If required by manufacturers, mask each type of masonry veneer when cleaning other types.
- C. Carefully clean masonry, removing large particles of mortar with a putty knife or chisel. Before the cleaning agent solution is applied, thoroughly soak surface with clean water. Apply solution with long-handled, stiff fiber brush, taking precaution to cover clothing, hands, and arms to prevent burns. Place over area no greater than 15 to 20 sq. ft. before the wall is again hosed down with clear water immediately after cleaning. Remove all trace of cleaner before it attacks the mortar joints.
- D. At least two weeks prior to time cleaning is to be done, clean a 20 sq. ft. sample area of wall, designated by Architect. After two week interval, Architect will inspect and if he finds no adverse affects, Contractor shall clean remaining wall. Should adverse affects be discovered, Architect will direct revised cleaning measures.

3.05 TESTING

- A. Prior to start of any concrete masonry construction perform prism tests in accordance with ASTM E 447, Method A, and ACI 530.
- B. During concrete masonry construction of walls 16 feet high, or higher, perform prism tests for each 5000 square feet of wall area, in accordance with ASTM E 447, Method B, and ACI 530.
- C. Walls or portions of a wall for which the prism test results do not meet the required average compressive strength shall be removed, replaced, and new prism tests performed for the replacement.

END OF SECTION

DIVISION 4 MASONRY

SECTION 04 22 23 ARCHITECTURAL CONCRETE MASONRY UNITS

PART 1 GENERAL

1.01 REFERENCES

- A. General Conditions and Special Conditions of the Contract and Division 1 of the Specifications are a part of this Section as if stated in full herein.

1.02 SUMMARY

- A. Provide Architectural concrete masonry units (Split-face block), in place, with reinforcing, flashing, control joints, and other accessories for structurally sound walls and partitions.
- B. Provide decorative cast stone panels, solids, and special shapes required by Drawings for sills, caps and other unique conditions.

1.03 TESTING

- A. The Contractor shall employ the services of a qualified testing agency and laboratory to perform testing of masonry as required in these Specifications.
- B. The Contractor shall give timely notice to the testing agency prior to the start of masonry work and during the progress of masonry work so that prisms can be made and tested to adequately control the quality of the work.

1.04 SAMPLE WALL

- A. At starting of masonry work, build a sample section of Architectural (CMU) wall, approximately 4 x 8 feet, representative of the proposed method of laying and workmanship and secure Architect's approval before proceeding with the remaining work. Sample wall section may become part of finished walls, if approved. Build additional samples if required.

1.05 DELIVERY, STORAGE, AND HANDLING

- A. Deliver and store on the site, Architectural CMU, sufficient in quantity for the entire job, and secure approval by Architect before placing any of same in the work.
- B. Store Architectural CMU on pallets above grade.
- C. Handle and transport Architectural CMU using methods that will protect them from damage. Replace any damaged units at no cost to the Owner.

PART 2 PRODUCTS

2.01 LIGHTWEIGHT ARCHITECTURAL CONCRETE MASONRY UNITS

- A. Units shall be made with Haydite aggregate and conform to the following:
 - 1. ASTM C 90 Hollow Load-Bearing Concrete Masonry Units, Type II.
 - 2. Minimum Compressive Strength (PSI)
 - a. Individual Units – 2,500 psi.
 - b. Average of 3 units – 2,800 psi.
 - 3. All units shall be manufactured with an integral water repellent admixture applied at the dosage recommended by the admixture manufacturer. The mortar shall have the recommended dosage to complete the system.
 - 4. Physical Requirements:
 - a. All units shall have a minimum age of 7 days prior to delivery to the jobsite.
 - b. Face Shell (FST) and web (WT) thickness for hollow units shall conform to the requirements listed.

Nominal Width (W) of Units – Inches	Face Shell Thickness (FST) min. inches	WebA minimum Thickness Inches	Equivalent WebB minimum Thickness Inches
4	¾	¾	1 5/8
6	1	1	2 ¼
8	1 ¼	1	2 ¼
10	1 3/8	1 1/8	2 ½
12	1 ½	1 1/8	2 ½

- c. Average of measurements on 3 units taken at the thinnest point, when measured as described in C140. When this Standard is used for split face units, a maximum of 10 percent of a split face shell area may have thickness less than those shown, but not less than ¾ inch.
- 5. All units shall be sound and free of cracks or other defects that would interfere with the proper placing of the unit or would significantly impair the strength or permanence of the construction.
- 6. Units used in exposed wall construction, the face or faces that are exposed shall not show objectionable imperfections when viewed from a distance of no less than 20 ft. under diffused lighting.
- 7. The finished surfaces that will be exposed shall conform to an approved sample consisting of no less than two units of each color.
- 8. Sizes: Nominal 8" x 16" face, two-cell units of 4", 6", 8" or 12" thickness as indicated, with half units, square-end corner units, solid units, jamb units, brick units, header units, bond beam lintel units, bullnose units, pilaster units, and other units necessary to maintain the bond and as otherwise indicated.

9. A test panel shall be constructed at contractor's expense. The panel is to be no less than 4' high by 6' long and shall be viewed for acceptance at a distance of no less than 20 feet under diffused light. The tooling of mortar, general quality, texture, and color of block shall be as required for the project and by the project documents.

B. Lightweight Architectural concrete masonry units shall be as manufactured by Joplin Building Materials, Joplin, Missouri, or approved equal, approved seven (7) days before bidding.

C. Architectural concrete masonry units, required to be in fire rated walls, as indicated on the Drawings, shall be certified by a recognized testing agency to have the required time-design fire resistance rating.

D. Perform prism testing in accordance with Article 3.05. Average compressive strength of 3 prisms shall not be less than 2000 psi.

2.02 DECORATIVE CAST STONE

A. Cast stone shall be Accent Cast Stone as manufactured by Joplin Building Materials.

B. Units shall be of the dimensions and design indicated on the Drawings. Color shall be as selected by Architect.

2.03 REINFORCEMENT (BLOCK MESH)

A. Single Wythe Exterior Walls: Dur-O-Wal extra heavy truss design, 3/16" side rods and No. 9 cross rods, wall reinforcing, of proper size and shape as required for wall thickness as shown on the Drawings. All walls shall have reinforcing at 16" o.c. vertically. Stacked bond load bearing walls shall have in addition, reinforcing at 8" o.c. in the top three courses.

B. Provide corresponding prefabricated corner and tee reinforcement at all corners and intersections.

2.04 REINFORCEMENT (BARS)

A. ASTM A 615, Grade 60.

2.05 CONCEALED FLASHING

A. Concealed flashing, where indicated on Drawings, shall be TAMKO TW THRU-WALL flashing, 40 mil (0.040") as manufactured by Tamko Roofing Products, or approved equal.

B. Base flashing for single wythe exterior (walls, see Section 04 09 60).

2.06 CAVITY WALL INSULATION

A. Insulation boards shall be extruded polystyrene board, 2 inch thickness, 16 inches wide.

1. Aged R-value: 5.0 per inch in accordance with ASTM C 518.

2. Water Vapor Permeance: 0.4 - 1.1 perms in accordance with ASTM E 96.
- B. Masonry Wall cell Insulation, See Section 07 21 00.

PART 3 EXECUTION

3.01 EXAMINATION

- A. Examine areas, preparatory work, and conditions under which work of this Section will be performed. Correct any unsatisfactory conditions. Do not proceed with masonry work until unsatisfactory conditions have been corrected.
- B. Beginning masonry work indicates acceptance of existing conditions.

3.02 INSTALLATION

- A. Lay no units having a film of water or frost on their surfaces.
- B. Lay no masonry when temperature is below 45 degrees F, unless it is rising, and at no time when below 40 degrees F, without Architect's permission. Such permission shall not relieve the Contractor from responsibility for the work, however. If permitted to work below 40 degrees F, make provisions to heat and dry materials and protect work from freezing.
- C. Build in bolts, ties, other metal anchors, sleeves, miscellaneous metals, and wood nailing strips as necessary to secure masonry together or to other materials. Use no continuous wood nailing strips.
- D. Build in steel lintels, bearing plates and flashings in contact with masonry. Bed flashings in mortar.
- E. Close up any recesses after pipes, ducts, conduits and other items are in and have been inspected by Architect and/or other proper authorities and do all patching after other trades have completed their work. Special attention shall be taken in closing all voids at cuts for outlet boxes, plumbing rough-ins, cleanouts, or other temporary openings.
- F. Cut exposed masonry with masonry saw to produce clean-cut edges. Other than water used in cutting operations, allow no wetting of blocks prior to laying.
- G. At end of each work day or shut down period, cover walls with strong waterproof membrane overlapping walls 12 inches minimum on each side and securely anchor in place.
- H. Use a full height story pole at all corners. Level first and frequent courses with instrument.
- I. Build in door and window frames and their anchors. Slush steel door frame jambs and heads full of grout. Slush cells full of mortar where excessive cutting for conduit or other devices has weakened masonry.

- J. Where fresh masonry adjoins previously set masonry, clean, roughen and lightly wet the set masonry before joining with new. Where stop-offs are necessary in horizontal runs, rake back the masonry; toothing not permitted unless approved by Architect.
- K. Build walls and partitions to dimensions indicated, in courses 8" high in running bond with units stacked one over the other with vertical joints offset, at the locations indicated on the Drawings.
- L. Reinforce walls and partitions with block mesh using appropriate types indicated above and in nominal width of wall or partition. Unless indicated otherwise, place a layer immediately above and below openings and elsewhere in every second course, with ends lapped 6" and alternately staggered. Bond corners and intersections with prefabricated corner and partition units.
- M. Set reinforcing bars in bond beam lintel units and shear walls. Position bars as indicated, fill cavity with grout and puddle to effect good contact with steel and block. Finished lintel must bear 8" minimum at each jamb.
- N. Install all special shapes as indicated on Drawings or as required.
- O. Where partitions abut exterior walls, rake out continuous vertical joint 3/8" x 1" to receive caulking by other trades, as specified in Section 07 92 00.
- P. Where room finish schedule indicates that rooms have no base (none) bedding mortar joint shall be pressed tight and flush to the face of the block.

3.03 JOINTS

- A. Set in mortar joints 3/8" thick with full coverage on vertical and horizontal face shells. Mortar shall have recommended dosage of water repellent admixture compatible with the Architectural concrete masonry unit integral water repellent.
- B. Except as noted, after mortar has begun to set, compact with tool to form concave joints where such joints will be exposed. Where concealed behind gypsum board or other finishes, compact joints smooth and flush. Brush excessive mortar from edges. After mortar has set, buff any remaining protruding mortar from joints.

3.04 POINTING AND CLEANING

- A. At building completion, when roofing work and heating system is operational or at such other time as Architect may direct, point up all exposed masonry, fill all holes and joints; remove loose mortar, cut out defective joints, repair cracks and defects, and repoint where necessary. Thoroughly clean masonry surfaces to be exposed, painted or unpainted.
- B. After walls have been "topped-out" and allowed to dry a minimum of seven (7) days, clean split-face veneer units along with face brick surfaces with cleaner; the specific formulation of cleaning agent to be determined by consultation between cleaner manufacturer and masonry manufacturer,

based on the final masonry selection and the installation conditions. Apply cleaning agent and rinse per manufacturer's directions and as hereinafter specified. If required by manufacturers, mask each type of masonry veneer when cleaning other types.

- C. Carefully clean masonry, removing large particles of mortar with a putty knife or chisel. Before the cleaning agent solution is applied, thoroughly soak surface with clean water. Apply solution with long-handled, stiff fiber brush, taking precaution to cover clothing, hands, and arms to prevent burns. Place over area no greater than 15 to 20 sq. ft. before the wall is again hosed down with clear water immediately after cleaning. Remove all trace of cleaner before it attacks the mortar joints.
- D. At least two weeks prior to time cleaning is to be done, clean a 20 sq. ft. sample area of wall, designated by Architect. After two week interval, Architect will inspect and if he finds no adverse affects, Contractor shall clean remaining wall. Should adverse affects be discovered, Architect will direct revised cleaning measures.

3.05 TESTING

- A. Prior to start of any concrete masonry construction perform prism tests in accordance with ASTM E 447, Method A, and ACI 530.
- B. During concrete masonry construction of walls 16 feet high, or higher, perform prism tests for each 5000 square feet of wall area, in accordance with ASTM E 447, Method B, and ACI 530.
- C. Walls or portions of a wall for which the prism test results do not meet the required average compressive strength shall be removed, replaced, and new prism tests performed for the replacement.

END OF SECTION

SECTION 06 13 20 WOOD TRUSSES

PART 1 GENERAL

1.01 REFERENCES

- A. General Conditions and Special Conditions of the Contract and Division 1 of the Specifications are a part of this Section as if stated in full herein.
- B. Reference Standards: The design and fabrication of wood trusses shall conform to:
 - 1. "National Design Specifications for Stress Grade Lumber and Its Fastenings" by National Forest Products Association (latest revision).
 - 2. "Timber Construction Standards" by American Institute of Timber Construction (latest revision).
 - 3. "Design Specifications for Light Metal Plate Connected Wood Trusses" by Truss Plate Institute (latest revision).

1.02 SECTION INCLUDES

- A. The work in this section shall consist of furnishing all materials, equipment and labor necessary for the prefabrication, delivery, and permanent setting of wood trusses shown on the Drawings.
- B. The work shall include all the miscellaneous parts, including bridging, temporary and permanent bracing, and all related items of hardware, metal hangers, anchors and special metal shapes deemed by the truss manufacturer to be necessary for the proper prefabrication, erection, assembly, supporting, and anchoring of the wood trusses.

1.03 DESIGN REQUIREMENTS

- A. Roof trusses shall be designed for the live load and bottom chord load indicated on the Drawings plus dead load.
- B. Design calculations for trusses shall be by a qualified Structural Engineer registered in the State of Missouri and pertinent data, calculations, and shop drawings shall bear his Professional Engineer's Seal.

1.04 SUBMITTALS

- A. Shop drawings of proposed trusses showing member sizes, and connections shall be submitted to the Architect for approval.
- B. Design calculations shall be submitted to the Architect indicating conformance to required loads, codes, and standards.

1.05 QUALITY ASSURANCE

- A. All trusses and other roof structural components shall be fabricated in a properly equipped manufacturing facility of a permanent nature.
- B. Trusses shall be manufactured by experienced workmen, using precision cutting and truss fabricating equipment, under the direct supervision of a qualified foreman. All trusses shall be fabricated under strict rules of inspection and quality control, open to the inspection of the Architect or his representative at all times.
- C. Each truss shall be stamped with the name and address of the truss manufacturer.
- D. Field Assembly: Where field assembly of the truss sub-components is necessary, the connections shall be in accordance with the details shown on the truss design drawings, approved by the Architect.

PART 2 PRODUCTS

2.01 LUMBER

- A. All lumber used for truss members shall conform to the published stress ratings for the species and grades as set out in the official grading rules of the appropriate lumber association or as listed in the referenced standards. Wherever notes on the Drawings or truss engineering designs calls for lumber which exceeds the minimum set forth therein, the Drawings and/or truss engineering designs shall govern.
- B. Moisture: At the time of fabrication, the moisture content of all lumber shall be within the proper limits, as stated in the reference standards.
- C. Dimensions: All lumber shall be kiln-dried fir or yellow pine of the fully recognized nominal sizes shown on the Drawings or truss engineering designs. All members shall be cut from lumber.

2.02 CONNECTIONS

- A. All truss connector plates shall be manufactured from ASTM A 446, Grade A prime commercial quality galvanized sheet steel of no less than 20 gauge thickness which has a minimum yield of 33,000 psi and a minimum ultimate tensile strength of 45,000 psi. The corrosion resistant coating shall be ASTM A 525, G90 or G60 commercial class hot dipped galvanized before stamping.
- B. Framing anchors and ties shall be provided by the Contractor in accordance with the Drawings.

2.03 FABRICATION

- A. All truss members shall be accurately cut to length, angle, and be true to line to assure tight joints for finished truss.

- B. All truss members and connector plates shall be properly placed in special jigs and the members tightly clamped in place, remaining in that position until the connector plates have been pressed into the lumber simultaneously on both sides of the joints.
- C. Camber shall be built into the trusses by the fabricator at a rate $1.5 \times$ (dead load + live load deflection) by properly positioning members in fabrication jig.

PART 3 EXECUTION

3.01 HANDLING, ERECTION, AND BRACING

- A. Fabricated trusses and sub-components shall be so handled and stored that they are not subject to damage. If the trusses are to be stockpiled prior to erection, sufficient bearing points and/or bracing shall be provided to prevent excessive lateral bending or tipping over.
- B. Erect trusses using procedures, handling, safety precautions, and temporary bracing to prevent toppling or dominoing of the trusses during erection, and any other safeguards or procedures consistent with good workmanship and good building erection practices.
- C. During the entire construction period, Contractor shall provide means for adequate distribution of concentrated loads so that the carrying capacity of any one truss and/or other component is not exceeded.
- D. Proper erection bracing shall be installed to hold the trusses true and plumb and in safe condition until permanent truss bracing and bridging can be solidly nailed in place to form a structurally sound roof framing system. All erection and permanent bracing shall be installed and all components permanently fastened before the application of any loads.
- E. The permanent structural horizontal or diagonal truss bracing, to ensure the overall rigidity of the roof system, shall be in accordance with the Drawings and manufacturer's shop drawings.

END OF SECTION

SECTION 06 17 10 LAMINATED VENEER LUMBER

PART 1 GENERAL

1.01 REFERENCES

- A. General Conditions and Special Conditions of the Contract and Division 1 of the Specifications are a part of this Section as if stated in full herein.
- B. Product of this section shall be Versa-Lam Products manufactured by Boise Engineered Wood Products or approved equal.

1.02 SECTION INCLUDES

- A. The work in this section shall consist of furnishing all materials, equipment and labor necessary for the installation of Versa-Lam Members shown on the drawings, specified herein and required to complete the work.
- B. The work shall include all the miscellaneous parts, including bridging, temporary and permanent bracing, and all related items of hardware, metal hangers, anchors and special metal shapes deemed by the truss manufacturer to be necessary for the proper erection, supporting, and anchoring of the Versa-Lam Beams.

1.03 DESIGN REQUIREMENTS

- A. Versa-Lam members sizes as shown on the drawings have been selected from Boise Engineered wood products/Eastern Engineered Wood Products specifiers guide.

1.04 SUBMITTALS

- A. Shop drawings of proposed Versa-Lam members showing member sizes, and connections shall be submitted to the Architect for approval.

1.05 QUALITY ASSURANCE

- A. All laminated veneer lumber shall be fabricated in a properly equipped manufacturing facility of a permanent nature.
- B. Each member supplied shall be stamped with the name and address of the manufacturer.

PART 2 PRODUCTS

2.01 MATERIALS

- A. Southern Pine, Eucalyptus or Douglas fir veneers, laminated in a press with all grain parallel with the length of the member. Glues used in lamination are phenol formaldehyde and isocyanate exterior-type adhesives which comply with ASTM D2559.

2.02 DESIGN

- A. VERSA-LAM® members shall be sized and detailed to fit the dimensions and loads indicated on the plans.
- B. All designs shall be in accordance with allowable values developed in accordance with ASTM D5456 and listed in the governing code evaluation service's report and section properties based upon standard engineering principles.
- C. Verification of design of the VERSA-LAM® members by complete calculations shall be available upon request.

2.03 FABRICATION

- A. VERSA-LAM® members shall be manufactured in a plant evaluated for fabrication by the governing code evaluation service and under the supervision of a third-party inspection agency listed by the corresponding evaluation service.

PART 3 EXECUTION

3.01 STORAGE

- A. VERSA-LAM® members, if stored prior to erection, shall be stored on stickers spaced a maximum of 15 ft. apart. All members shall be stored on a dry, level surface and protected from the weather.
- B. They shall be handled with care so they are not damaged.

3.02 INSTALLATION

- A. VERSA-LAM® members are to be installed in accordance with the plans and Boise EWP's Installation Guide.
- B. Temporary construction loads which cause stresses beyond design limits are not permitted.
- C. Erection bracing shall be provided to assure adequate lateral support for the individual members and the entire system until the sheathing material has been applied.

END OF SECTION

SECTION 06 40 00 ARCHITECTURAL WOODWORK

PART 1 GENERAL

1.01 REFERENCES

- A. General Conditions and Special Conditions of the Contract and Division 1 of the Specifications are a part of this Section as if stated in full herein.

1.02 SUMMARY

- A. This Section includes furnishing and installing:
 - 1. Standing and running trim.
 - 2. Cabinets and shelving.
 - 3. Countertops.

1.03 SUBMITTALS

- A. Shop Drawings: Submit shop drawings indicating dimensions, materials, fastenings, joinery, and interface with other materials.
 - 1. Cabinet shop drawings shall include plans, elevations, sections, trim details, and hardware.
- B. Samples: Submit samples of plastic laminate and grommets for color selection.
- C. Warranty: At the completion of the cabinetry and casework, submit manufacturer's written warranty covering installation, material, and workmanship for not less than one (1) year from time of completion of the work.

PART 2 PRODUCTS

2.01 GENERAL REQUIREMENTS

- A. All wood kiln-dried to 6% to 11% moisture content for interior; 9% to 12% for exterior.
- B. All oak suitable for transparent finish.

2.02 INTERIOR TRIM MATERIALS

- A. Solid lumber for interior finish trim unless specified otherwise on Drawings, shall be select oak.

2.03 CABINETS AND CASEWORK

- A. Cabinets and casework, unless noted otherwise, shall be as follows:
 - 1. Exposed face of cabinets shall be high pressure laminate of flush overlay construction.
 - 2. Furnish all anchors required for attachment of all units to walls and unit to unit.

3. All cabinets shall conform to custom grade as defined in AWI Quality Standards, Sixth Edition, Version 1.1, Section 400B.
4. Colors shall be as selected by Architect for all laminate interiors, exteriors and trim.

B. Construction:

1. **Joinery:** Cabinet corner joints incorporating dowel pin construction must be glued and clamped under pressure to assure rigid load-bearing corner joints.
2. **End Panels:** All cabinet ends shall be $\frac{3}{4}$ " thick panels of balanced construction, precision bored for dowel pins installed in horizontal cabinet members. All units shall have continuous one piece end panels for added load capabilities.
3. **Bottoms and Tops:** All cabinet bottoms and tops shall be $\frac{3}{4}$ " thick panels of balanced construction. Panels shall be precision bored to receive fluted dowel pins, inserted with glue. Dowel pins shall extend from the panel ends into mating hole patterns in the cabinet's side panels.
4. **Doors:** Solid hinged doors shall be $\frac{3}{4}$ " thick material of balanced construction. Doors 36" and less in height shall have two (2) hinges per door. Door over 36" must have three (3) hinges per door. All edges must be finished with set-in PVC edging of a minimum 3 mm thickness.
5. **Cabinet Backs:** All unit backs shall be $\frac{1}{4}$ " thick panels with laminate interior surface.
6. **Drawers:** Fronts shall be $\frac{3}{4}$ " thick material of balanced construction. Sides and ends shall be medium density particle board. Bottoms shall be $\frac{1}{4}$ " medium density particle board. Fronts shall be finished with set-in PVC edging of a minimum 3 mm thickness.
7. **Adjustable Shelves:** All adjustable shelves in cabinets shall be $\frac{3}{4}$ " thick when under 36" long and 1" thick when 36" long and over. Front edges shall have a set-in PVC edging of a minimum 3 mm thickness.

C. Plastic Laminate Countertops:

1. High pressure decorative plastic laminate shall be bonded to top, edges, and backsplash of industrial grade medium density particle board or $\frac{3}{4}$ " AC plywood as detailed on the Drawings. Make straight runs in one piece whenever possible.
2. Countertops shall conform to custom grade as defined in AWI Quality Standards, Sixth Edition, Version 1.1, Section 400C.
3. Provide a post-formed high pressure decorative laminate edge at countertop edges not having a backsplash.
4. General Contractor shall cut holes in countertops for sinks, lavatories, grommets, and other inserts as required by various trades.

D. Material:

1. **Cores:** Cores shall be medium density particle board.
2. **Interior Surfaces:** All interior surfaces shall be laminated. Surfacing shall perform as tested under standards of NEMA tests LQ1-3.01 through LQ1-3.10.
3. **Exterior Surfaces:** Plastic laminate for exterior surfaces (doors, drawers, cabinets, countertops and splashes) shall be bonded to base materials as specified. Plastic laminate shall be 0.050 inch nominal thickness as manufactured by Formica, Wilson Art, or Textolite.
4. **Edges:** Shelves and cabinet members shall be edged with plastic laminate. Doors, drawers and exposed shelving shall be edged with set-in PVC edging of a minimum 3 mm thickness.

E. Hardware:

1. Pulls: Stanley #4484.
2. Hinges: Blum 77M5580 Self Closing Hinge with 175L6600.22 Mounting Plates for Face Frame.
3. Shelf Supports: Dual pin, snap in place units for 32MM drilled holes.
4. Drawer Guides: K & V #1300.
5. Grommets: Doug Mockett #BG - color to match laminate.
6. All hardware shall have satin chromium finish unless otherwise noted.
7. Support Brackets for Counters: Standard mount bracket of 11 gauge steel, in sizes as indicated on the Drawings. Finish shall be powder coat in color selected by Architect.
 - a. Manufacturer: Gambas or A&M Hardware, Inc.

PART 3 EXECUTION

3.01 INSTALLATION

- A. Install all miscellaneous finish carpentry items indicated, in straight, true alignment with tight hairline joints between items.
 1. Apply finish in longest practical lengths; miter external corners; cope re-entrant corners; scarf splices, make all joints tight. Leave work in prime condition for finishes by other trades.
 2. In general, radius edges slightly, but where details indicate square edges, furnish as such and touch-sand exposed edges after installation.
 3. All countertop outside corners to have 1 ½" radius.
- B. Install hardware, metal, and other specialty items as indicated, where not installed by other trades.
- C. All cabinet bases shall be 2X treated wood and 4" x 4" block as detailed on the Drawings.
- D. Anchor all casework in place with concealed fastening systems and scribe to adjoining surfaces as required and as indicated in shop drawings.
- E. Field Jointing Tops:
 1. Where practicable, make in same manner as factory jointing using dowels, splines, adhesives, and fasteners recommended by manufacturer.
 2. Locate field joints as shown on accepted shop drawings, factory prepared so that there is no job site processing to top and edge surfaces.
 3. Abut top and edge surfaces in one true plane, with internal supports placed to prevent any deflection.
 4. Provide flush hairline joints in top units.
 5. Scribe and cut for accurate fit.

END OF SECTION

SECTION 06 40 00 ARCHITECTURAL WOODWORK

PART 1 GENERAL

1.01 REFERENCES

- A. General Conditions and Special Conditions of the Contract and Division 1 of the Specifications are a part of this Section as if stated in full herein.

1.02 SUMMARY

- A. This Section includes furnishing and installing:
 - 1. Standing and running trim.
 - 2. Cabinets and shelving.
 - 3. Countertops.

1.03 SUBMITTALS

- A. Shop Drawings: Submit shop drawings indicating dimensions, materials, fastenings, joinery, and interface with other materials.
 - 1. Cabinet shop drawings shall include plans, elevations, sections, trim details, and hardware.
- B. Samples: Submit samples of plastic laminate and grommets for color selection.
- C. Warranty: At the completion of the cabinetry and casework, submit manufacturer's written warranty covering installation, material, and workmanship for not less than one (1) year from time of completion of the work.

PART 2 PRODUCTS

2.01 GENERAL REQUIREMENTS

- A. All wood kiln-dried to 6% to 11% moisture content for interior; 9% to 12% for exterior.
- B. All oak suitable for transparent finish.

2.02 INTERIOR TRIM MATERIALS

- A. Solid lumber for interior finish trim unless specified otherwise on Drawings, shall be select oak.

2.03 CABINETS AND CASEWORK

- A. Cabinets and casework, unless noted otherwise, shall be as follows:
 - 1. Exposed face of cabinets shall be high pressure laminate of flush overlay construction.
 - 2. Furnish all anchors required for attachment of all units to walls and unit to unit.

3. All cabinets shall conform to custom grade as defined in AWI Quality Standards, Sixth Edition, Version 1.1, Section 400B.
 4. Colors shall be as selected by Architect for all laminate interiors, exteriors and trim.
- B. Construction:
1. Joinery: Cabinet corner joints incorporating dowel pin construction must be glued and clamped under pressure to assure rigid load-bearing corner joints.
 2. End Panels: All cabinet ends shall be $\frac{3}{4}$ " thick panels of balanced construction, precision bored for dowel pins installed in horizontal cabinet members. All units shall have continuous one piece end panels for added load capabilities.
 3. Bottoms and Tops: All cabinet bottoms and tops shall be $\frac{3}{4}$ " thick panels of balanced construction. Panels shall be precision bored to receive fluted dowel pins, inserted with glue. Dowel pins shall extend from the panel ends into mating hole patterns in the cabinet's side panels.
 4. Doors: Solid hinged doors shall be $\frac{3}{4}$ " thick material of balanced construction. Doors 36" and less in height shall have two (2) hinges per door. Door over 36" must have three (3) hinges per door. All edges must be finished with set-in PVC edging of a minimum 3 mm thickness.
 5. Cabinet Backs: All unit backs shall be $\frac{1}{4}$ " thick panels with laminate interior surface.
 6. Drawers: Fronts shall be $\frac{3}{4}$ " thick material of balanced construction. Sides and ends shall be medium density particle board. Bottoms shall be $\frac{1}{4}$ " medium density particle board. Fronts shall be finished with set-in PVC edging of a minimum 3 mm thickness.
 7. Adjustable Shelves: All adjustable shelves in cabinets shall be $\frac{3}{4}$ " thick when under 36" long and 1" thick when 36" long and over. Front edges shall have a set-in PVC edging of a minimum 3 mm thickness.
- C. Plastic Laminate Countertops:
1. High pressure decorative plastic laminate shall be bonded to top, edges, and backsplash of industrial grade medium density particle board or $\frac{3}{4}$ " AC plywood as detailed on the Drawings. Make straight runs in one piece whenever possible.
 2. Countertops shall conform to custom grade as defined in AWI Quality Standards, Sixth Edition, Version 1.1, Section 400C.
 3. Provide a post-formed high pressure decorative laminate edge at countertop edges not having a backsplash.
 4. General Contractor shall cut holes in countertops for sinks, lavatories, grommets, and other inserts as required by various trades.
- D. Material:
1. Cores: Cores shall be medium density particle board.
 2. Interior Surfaces: All interior surfaces shall be laminated. Surfacing shall perform as tested under standards of NEMA tests LQ1-3.01 through LQ1-3.10.
 3. Exterior Surfaces: Plastic laminate for exterior surfaces (doors, drawers, cabinets, countertops and splashes) shall be bonded to base materials as specified. Plastic laminate shall be 0.050 inch nominal thickness as manufactured by Formica, Wilson Art, or Textolite.
 4. Edges: Shelves and cabinet members shall be edged with plastic laminate. Doors, drawers and exposed shelving shall be edged with set-in PVC edging of a minimum 3 mm thickness.

E. Hardware:

1. Pulls: Stanley #4484.
2. Hinges: Blum 77M5580 Self Closing Hinge with 175L6600.22 Mounting Plates for Face Frame.
3. Shelf Supports: Dual pin, snap in place units for 32MM drilled holes.
4. Drawer Guides: K & V #1300.
5. Grommets: Doug Mockett #BG - color to match laminate.
6. All hardware shall have satin chromium finish unless otherwise noted.
7. Support Brackets for Counters: Standard mount bracket of 11 gauge steel, in sizes as indicated on the Drawings. Finish shall be powder coat in color selected by Architect.
 - a. Manufacturer: Gambas or A&M Hardware, Inc.

PART 3 EXECUTION

3.01 INSTALLATION

- A. Install all miscellaneous finish carpentry items indicated, in straight, true alignment with tight hairline joints between items.
 1. Apply finish in longest practical lengths; miter external corners; cope re-entrant corners; scarf splices, make all joints tight. Leave work in prime condition for finishes by other trades.
 2. In general, radius edges slightly, but where details indicate square edges, furnish as such and touch-sand exposed edges after installation.
 3. All countertop outside corners to have 1 1/2" radius.
- B. Install hardware, metal, and other specialty items as indicated, where not installed by other trades.
- C. All cabinet bases shall be 2X treated wood and 4" x 4" block as detailed on the Drawings.
- D. Anchor all casework in place with concealed fastening systems and scribe to adjoining surfaces as required and as indicated in shop drawings.
- E. Field Jointing Tops:
 1. Where practicable, make in same manner as factory jointing using dowels, splines, adhesives, and fasteners recommended by manufacturer.
 2. Locate field joints as shown on accepted shop drawings, factory prepared so that there is no job site processing to top and edge surfaces.
 3. Abut top and edge surfaces in one true plane, with internal supports placed to prevent any deflection.
 4. Provide flush hairline joints in top units.
 5. Scribe and cut for accurate fit.

END OF SECTION

DIVISION 7 THERMAL AND MOISTURE PROTECTION

SECTION 07 19 00 WATER REPELLENTS

PART 1 GENERAL

1.01 REFERENCE

- A. General Conditions and Special Conditions of the Contract and Division 1 of the Specifications are a part of this Section as if stated in full herein.

1.02 SUMMARY

- A. Work of this Section includes furnishing and applying water repellent material to the exterior of concrete masonry veneer.

1.03 RELATED SECTIONS

- A. Section 04 22 23 Architectural Concrete Masonry Units.
- B. Section 04 73 00 Manufactured Stone Veneer

1.04 QUALITY ASSURANCE

- A. Applicators shall have a minimum of 3 years experience in applying the specific product used.
- B. Product manufacturer shall have a minimum of 10 years experience in the production of siloxane based water repellents.

PART 2 PRODUCTS

2.01 MANUFACTURERS

- A. Water repellent treatment of concrete masonry shall be one of the following:
 1. Prime A Pell 200, manufactured by Chemprobe Technologies, Inc. (214) 271-5551.
 2. Weather Seal (Siloxane), as manufactured by Prosoco, Inc. (800) 255-4255.
 3. OKON W-1, as manufactured by Okon, Inc., (303) 232-3571.
- B. Masking and protection of adjacent materials shall be products recommended by the manufacturer of the water repellent.

PART 3 EXECUTION

3.01 PREPARATION

- A. Ensure that surfaces to receive water repellent are clean and that joint sealants are in place and cured.
- B. Determine that minimum surface and ambient temperatures required by the manufacturer will be present and will be rising.

3.02 APPLICATION

- A. Apply water repellent in strict conformance with manufacturer's instructions.
- B. Do not apply water repellent when rain is imminent.
- C. Do not apply to material that will be below grade.

END OF SECTION

SECTION 07 21 00 THERMAL INSULATION

PART 1 GENERAL

1.01 REFERENCES

- A. General Conditions and Special Conditions of the Contract and Division 1 of the Specifications are a part of this Section as if stated in full herein.

1.02 SUMMARY

- A. Provide, install and complete all building insulation shown on the Drawings or specified herein, or both, including:
 - 1. Perimeter insulation under floor slab.
 - 2. Masonry wall rigid insulation (Specified in Section 04 22 00).
 - 3. Batt insulation (ceilings, walls & misc. closures).
 - 4. Masonry wall insulation in non-grouted cells.

1.03 DELIVERY, STORAGE, AND HANDLING

- A. Deliver products in manufacturer's original packaging with labels indicating the manufacturer, type of material, thickness, and R value.
- B. Handle and store products in a manner to prevent damage and moisture absorption.

PART 2 PRODUCTS

2.01 INSULATION MATERIALS

- A. Board Insulation at Perimeter: Insulation boards shall be 2 inches thick extruded polystyrene board of the dimensions indicated on the Drawings.
 - 1. Aged R-value: 5.0 per inch in accordance with ASTM C 518.
 - 2. Water Vapor Permeance: 0.4 - 1.1 perms in accordance with ASTM E 96.
- B. Exterior single wythe Masonry Wall Insulation: Pressure injected foam as manufactured by Thermal Corporation of America, (Thermco) or Polymaster, Inc. (R-501). The foam insulation shall be non-conductor of electricity and have a minimum fire rating of 2 hours. Residual formaldehyde content shall be less than 1%
- C. 4", R-11 and 6", R-19 kraft faced fiberglass batts or rolls as required for miscellaneous areas as shown on the Drawings.
- D. 10 ½" & 13", R-38 kraft faced fiberglass insulation (batts or rolls) for roof insulation between wood trusses.

PART 3 EXECUTION

3.01 INSTALLATION

- A. Install insulation in as great a length as possible, minimizing end joints.
- B. Provide adequate coverage so that insulation R value is provided for a complete wall or ceiling area (except for grouted CMU cells).
- C. Fit insulation into constricted areas to achieve complete coverage.
- D. Pressure inject foam insulation into CMU cells in accordance with instructions of the manufacturer and using equipment approved by the manufacturer.

END OF SECTION

SECTION 07 27 00 AIR BARRIER

PART 1 GENERAL

1.01 REFERENCE

- A. General Conditions and Special Conditions of the Contract and Division 1 of the Specifications are a part of this Section as if stated in full herein.

1.02 SUMMARY

- A. Work of this Section includes furnishing and applying air barrier material to the exterior of plywood sheathing.

1.03 References:

- A. American Society for Testing and Materials
- B. Technical Association of the Pulp and Paper Industry
- C. American Association of Textile Chemists and Colorists

1.04 Submittals:

- A. General: Submit each item in this Article according to the conditions of the Contract and Division I Specifications Sections.
- B. Product Data: Submit product specifications, technical data and installation instructions of manufacturer equaling or exceeding those specified.

1.05 Quality Assurance

- A. Qualifications:
 - 1. Installer with successful experience in the installation of air barrier/secondary weather resistant barriers.
- B. Install job mock-up using specified air barrier/secondary weather resistant barrier with system of fastening and taping seams as per manufacturer's instructions. Obtain architect's approval of system for appearance and workmanship standard.

PART 2 PRODUCTS

2.01 MANUFACTURERS

- A. DuPont Tyvek CommercialWrap (800-448-9835) or approved equal.

2.02 MATERIALS

- A. DuPont™ Tyvek® CommercialWrap®: A flash spunbonded olefin, non-woven, non-perforated secondary weather resistant barrier.

B. Performance Characteristics

1. AATCC-127, Water Penetration Resistance, exceeded at 280
2. TAPPI T-460, Gurley Hill (sec/100cc) Air infiltration at >1500 seconds
3. ASTM E 96 Method B(g/m²-24hr.)Water vapor transmission of 200
4. TAPPI T-41D, Basis weight of 2.7oz/yd
5. ASTM E96 Method B, Water Vapor Transmission, 28 perms
6. ASTM E1677, Air Retarder Material Standard Specification, Type I air barrier

C. Sealing Tape/Fasteners

1. DuPont™ Tyvek® Tape, DuPont Weatherization Systems.
2. For steel frame construction: DuPont™ Tyvek® Wrap Cap Screws, DuPont Weatherization Systems. 1 5/8" rust resistant screws with 2" diameter plastic cap

PART 3 - EXECUTION

3.01 INSTALLATION

A. A. Install Air Barrier over exterior side of exterior wall sheathing.

1. Install Air Barrier after sheathing is installed and before windows and doors are installed. Install lower level barrier prior to upper layers to ensure proper shingling of layers.
2. Overlap Air Barrier at corners of building by a minimum of 12 inches.
3. Overlap Air Barrier vertical seams by a minimum of 6 inches.
4. Ensure barrier is plum and level with foundation, and unroll extending Air Barrier over window and door openings.
5. Attach Air Barrier to wood, insulated sheathing board or exterior gypsum with plastic cap nails every 12" to 18" on vertical stud line with wood stud framing, and screws with washers to metal stud framing. When attaching to masonry, use adhesive recommended by manufacturer.
6. Prepare window and door rough openings as follows:
 - a. Prepare each window rough opening by cutting a modified "T" pattern in the Air Barrier.
 1. Horizontally cut Air Barrier along bottom of header.
 2. Vertically cut Air Barrier down the center of window openings from the top of the window opening down to 2/3 of the way to the bottom of the window openings.
 3. Diagonally cut Air Barrier from the bottom of the vertical cut to the left and right corners of opening.

4. Fold side and bottom flaps into window opening and fasten every 6 inches. Trim off excess.
- b. Prepare each rough door opening by cutting a standard "P" pattern in the Air Barrier.
 1. Horizontally cut Air Barrier along bottom of door frame header and along top of sill.
 2. Vertically cut Air Barrier down the center of door openings from the top of the door opening (header) down to the bottom of the door opening (sill).
 3. Fold side flaps inside around door openings and fasten every 6 inches. Trim off excess.
7. Tape all horizontal and vertical seam of Air Barrier with DuPont™ Tyvek® Tape.
8. Seal all tears and cuts in Air Barrier with DuPont™ Tyvek® Tape.

END OF SECTION

This document specifies Metal Roofing Systems prefinished factory formed metal roofing marketed as MRS System 2500® steel and aluminum roofing systems and includes MRS flashing and Trim. MRS finish is a fluoropolymer (70% Kynar 500® or 70% Hylar 5000®) resin coating applied to aluminum or galvanized steel. (Kynar 500 is a registered trademark of Elf Atochem North American, Inc.; Hylar 5000 is a registered trademark of Ausimont USA.) This specification does not include other Metal Roofing Systems products, such as: coping systems and gravel stops.

**SECTION 07410
METAL ROOF & WALL PANELS**

PART 1 GENERAL

1.01 SUMMARY

- A. Section includes: Factory-formed metal roofing or soffits, including flashing and accessories.
Metal roofing includes:

MRS System 2500

Specifier Note: Revise paragraph below to suit project requirements. Add section numbers per CSI *Masterformat* and specifier's practice.

- B. Related Sections: Section(s) related to this section include:
1. Metal Roof Deck: Division 5 Metal Deck Sections.
 2. Wood Framing and Decking: Division 6 Rough Carpentry Section.
 3. Flashing and Trim: Division 7 Flashing and Sheet Metal Section.
 4. Coping and Gravel Stops: Division 7 Roof Specialties and Accessories Section.
 5. Sealants: Division 7 Joint Sealers Sections.

Specifier Note: Paragraphs below list industry standards referenced in this section. Verify use of listed standards and add edition date of standards retained. *Conditions of the Contract* or Division 1 References Section may establish edition date of standards referenced. This article does not require compliance with standard, but is merely a listing of references used.

1:02 REFERENCES

- A. American Society for Testing and Materials (ASTM):
- B. Underwriters Laboratories (UL Classified Tests):
- C. Sheet Metal and Air Conditioning Contractors National Association (SMACNA):
1. SMACNA Architectural Sheet Metal Manual

1:03 SYSTEM DESCRIPTION

- A. Performance Requirements: Provide sheet metal roofing that has been manufactured, fabricated and installed to withstand structural and thermal movement, wind loading and weather exposure to maintain manufacturer's performance criteria without defects, damage, failure of infiltration of water.
1. Wind-Uplift: Roof panel assembly shall comply with UL Classification 580 for UL Classified 90 rated assemblies
 2. Static Air Infiltration: Completed roof system shall have a maximum of .06 cfm/sf with 6.24 kPa air pressure differential as per ASTM E283/1680.
 3. Water Infiltration: No evidence of water penetration at an inward static air pressure differential of not less than 6.24 psf (43 kPa) and not more than 12.0 psf (83 kPa) as per ASTM E331/1646.

Specifier Note: Article below includes submittal of relevant data to be furnished by Contractor either before, during or after construction. Coordinate this article with Architect's and Contractor's duties and responsibilities in *Conditions of the Contract* and Division 1 Submittal Procedures Section.

1:04 SUBMITTALS

A. General: Submit listed submittals in accordance with *Conditions of the Contract* and Division 1 Submittal Procedures Section.

1. Product Data: Submit product data, including manufacturer's SPEC-DATA® product sheet, for specified products. (Make Spec-Data link to information located in the product section.

B. Shop Drawings:

1. Submit complete shop drawings and erection details, approved by the metal roofing manufacturer, to the architect (owner) for review. Do not proceed with manufacturer of roofing materials prior to review of shop drawings and field verification of all dimensions. Do not use drawings prepared by the architect (owner) for shop or erection drawings.
2. Shop drawings show roof plans, elevations, methods of erection, and flashing details.

C. Performance Tests:

1. Submit certified test results by a recognized testing laboratory in accordance with specified test methods for each panel system.

D. Samples: Submit selection and verification samples for finishes, colors and textures.

E. Quality Assurance Submittals: Submit the following:

1. Certificates: Product certificates signed by manufacturer certifying materials comply with specified performance characteristics and physical requirements.
2. Manufacturer's Instructions: Manufacturer's installation instructions.

F. Closeout Submittals: Submit the following:

1. Operation and Maintenance Date: Operation and maintenance date for installed products in accordance with Division 1 Closeout Submittals, Maintenance Data and Operation Data Section. Include methods for maintaining installed products and precautions against cleaning materials and methods detrimental to finishes and performance.
2. Project Warranty: Warranty documents specified herein.
A: Manufactures warranty: Submit, for owners acceptance, manufactures standard warranty document excuted by authorized company official. Manufacturer's warranty is in addition to and not limited of, other rights the owner may have under the contract documents.

Specifier Note: Coordinate paragraph below with manufacturer's warranty requirements. Metal Roofing Systems offers a 20-year non-prorated warranty covering a MRS finish, including color, fade, chalking and film integrity. Consult with manufacturer for specific project warranty requirements

1. Warranty Period: (specify term) years commencing on Date of Substantial Completion.

Specifier Note: Retain article below for proprietary method specification. Add product attributes, performance characteristics, material standards and descriptions as applicable. Use of such phrases as "or equal" or "or approved equal" may cause ambiguity in the specifications. Such phrases require verification - procedural, legal, regulatory and responsibility - for determining equivalence of products.

3. Record Documents: Project record documents for installed materials in accordance with Division 1 Closeout Submittals,, Project Record Documents Section.

Specifier Note: Article below should include prerequisites, standards, limitations and criteria which establish an overall level of quality for products and workmanship for this section. Coordinate below article with Division 1 Quality Assurance Section.

1:05 QUALITY ASSURANCE

- A. Installer Qualifications: Installer experienced in performing work of this section who has specialized in the installation of work similar to that required for this project.

- B. Sheet Metal Industry Standard: Comply with Sheet Metal and Air Conditioning Contractors National Association(SMACNA) *Architectural Sheet Metal Manual*.

Specifier Note: Retain paragraph below for erected assemblies, either onsite or offsite, required for review of Construction, coordination of work of several sections, testing or observation of operation. Mock-ups establish Standards by which work will be judged. Coordinate below with Division 1 Quality Control, Mock-up Requirements Section.

- C. Pre-Installation Meetings: Conduct pre-installation meeting to verify project requirements, substrate conditions, Manufacturer's installation instructions and manufacturer's warranty requirements. Comply with Division 1 Managements and Coordination, Project Meetings Section.

1:06 DELIVERY, STORAGE AND HANDLING

- A. General: Comply with Division 1 Product Requirements Sections.
 - 1. Ordering: Comply with manufacturer's ordering instructions and lead-time requirements to avoid construction delays.

- B. Delivery: Deliver materials in manufacturer's original, unopened, undamaged containers with identification labels intact. Identify fabricated components with UL 90 Classified label where appropriate.

- C. Storage and Protection: Store materials protected from exposure to harmful conditions. Store material in dry, above ground location.
 - 1. Stack prefinished material to prevent twisting, bending, abrasion, scratching and denting. Elevate one end of each skid to allow for moisture to run off.
 - 2. Prevent contact with material that may cause corrosion, discoloration or staining.
 - 3. Do not expose to direct sunlight or extreme heat trim material with factory applied strippable film.

1:07 PROJECT CONDITIONS

- A. Field Measurements: Verify actual measurements/openings by field measurements before fabrication; show recorded measurements on shop drawings. Coordinate field measurements, fabrication schedule with construction progress to avoid construction delays.

Specifier Note: Coordinate article below with *Conditions of the Contract* and with Division 1 Closeout Submittals, Warranty Section.

1:08 WARRANTY

- A. Project Warranty: Refer to *Conditions of the Contract* for project warranty provisions.

- B. Manufacturer's Warranty: Submit, for Owner's acceptance, manufacturer's standard warranty document executed by authorized company official. Manufacturer's warranty is in addition to and not a limitation of, other rights Owner may have under the Contract Documents.

Specifier Note: Coordinate paragraph below with manufacturer's warranty requirements. Metal Roofing Systems offers a 20-year nonprorated warranty covering MRS finish, including color, fade, chalking and Film integrity. Consult with manufacturer for specific project warranty requirements.

1. Warranty Period: (Specify term) years commencing on Date of Substantial Completion.

PART 2 PRODUCTS

Specifier Note: Retain article below for proprietary method specification. Add product attributes, performance characteristics, material standards and descriptions as applicable. Use of such phrases as "or equal" or "or approved equal" may cause ambiguity in the specifications. Such phrases require verification - procedural, legal, regulatory and responsibility - for determining equivalence of products.

2:01 SHEET METAL ROOFING

A. Manufacturer: Metal Roofing Systems

Specifier Note: Paragraph below is a supplement to *CSI Masterformat* and an addition to MANU-SPEC. Retain or delete paragraph below to suit project requirements and specifier's practice.

1. Contact: 7670 Mikron Drive, Stanley, NC 28164; Telephone (704) 820-3110; Fax (704) 820-0113

Specifier Note: Paragraphs below list proprietary roof panels offered by Metal Roofing Systems. Select roof panels appropriate to project. Panels are factory formed in lengths up to 55' (16.2 m). Matching flashing and trim may be factory formed or field formed from MRS material. Consult with manufacturer regarding product options. Selection product characteristics required; delete characteristics not required. Refer to manufacturer's SPEC-DATA product sheet.

Specifier Note: Below (MRS System 2500) panels are factory formed and tension leveled with an optional factory applied sealant bead for improved weather resistance. Panels feature a 2" (50.2 mm) leg height and a continuous inter-lock for structural performance and wind resistance. A concealed fastener system allows for thermal expansion/contraction while providing holddown strength. Two clips are available: a standard clip for mansard and fascia applications and a high performance clip roofing application and UL Classified 90 rated assemblies. Panels carry a UL Classified 90 rating over designated substrates and assemblies including 5/8" (16 mm) plywood, purlins and rigid insulation in conjunction with bearing plates (UL Classification Construction No. 90, 176, 180,238, and 238A. Panel features include Stiffener beads. Meets performance requirements of ASTM E1680 air infiltration test, ASTM E1646 water penetration test and ASTM E1592 air bag test. Consult with Metal Roofing Systems.

B. MRS SYSTEM 2500 panels and trim:

1. Seam Height: 2" (50.2 mm) minimum seam height.
2. Material: (24 ga.), (22 ga) G-90 Hot-dipped Galvanized Steel
3. Material: .032" ga (.8mm), .040" ga (.1mm) alloy 3105-H14 aluminum
4. Panel Dimension: 12" (305 mm), 14" (356 mm), 16" (406 mm), 18" (457 mm) o.c.

Specifier Note: Below eave notching is an option with manufacturer. Retain or delete as applicable.

5. Texture: (Smooth) (Stucco embossed texture) (Striations) (Stress Ribs).
6. Rating: UL Classified 90 rated (wind uplift) panel assembly.
7. Flashing and Trim: (Aluminum, (.032" ga, .040" ga, .050" ga (.8mm, .1mm, .13mm))(Steel, (24 ga, 22 ga))
8. Fasteners: Standard galvanized steel, non-penetrating high performance clips for roofing application and UL Classified 90 rated (wind uplift) assemblies and standard clips for mansard and fascia applications.

Specifier Note: Below sealant bead is an option with manufacturer. Retain or delete as applicable.

9. Sealant Bead: Factory applied sealant bead.

C. Panel Finish:

1. Panel Topside: MRS SYSTEM 2500 finish' color selected from Metal Roofing Systems. standard colors:
2. Panel Underside: Polyester washcoat with dry film thickness of 0.3 mils.

Specifier Note: Coordinate paragraph below with project requirements for selected sheet metal roofing system.

D. MRS SYSTEM 2500 Flashing and Trim: Manufacturer's standard flashing and trim profiles, factory formed, gauge as recommended by manufacturer, color and finish to match metal roofing panels.

Specifier Note: Edit paragraph below to suit project requirements, if substitutions are permitted, edit text below. Add text to refer to Division 1 Product Requirements, Product Substitution Procedures Section.

E. Substitutions: No substitutions permitted.

2:02 RELATED MATERIALS

A. General: Coordinate use of related materials:

1. Underlayment: ASTM D226, Type II No. 30 asphalt saturated organic roofing felt. Refer to Division 7 Roofing Sections.
2. Plywood Deck: 5/8" (16 mm) nominal thickness. Refer to Division 6 Rough Carpentry Section.
3. Nailable Insulation: 1" (25 mm) minimum to 3 1/2" (89 mm) maximum nominal thickness classified polyisocyanurate foamed plastic, 2 pct density, with factory laminated 7/16" (11 mm) thick APA rated Oriented Strant Board (OSB). Refer to Division 7 Insulation Sections or Division 6 Rough Carpentry Section.
4. Sealants: Elastometric joint sealants. Refer to Division 7 Joint Sealers Sections.

5. Bituminous Coating: Cold-applied asphaltic mastic. Provide compound free of asbestos fibers, sulfur components and other harmful impurities. Refer to Division 7 Damp proofing Section.

2:03 FABRICATION

A. General:

1. Continuous Length: Fabricate panels 55' (16.2 m) and less in one continuous length.
2. Trim and Flashings: Fabricate trim and flashings from same material as roof system material.
3. Portable Roll Former: Panels fabricated by portable roll former shall not be approved.

Specifier Note: Coordinate article below with finishes specified in sheet metal roofing article above.

2:04 FINISHES

A. MRS SYSTEM 2500 Factory Applied Finish:

1. Topside: Full-strength fluoropolymer (70% Kynar® 500 or Hylar® resin) system of 1.0 mil (.025 mm) total dry film thickness.
2. Underside: Wash coat of 0.3 - 0.4 mil dry film thickness.
3. Texture: (Smooth texture, dull matte specular gloss 25 - 35% at 60°) (Standard E-5 stucco embossed pattern).
4. Protective film: Strippable vinyl film applied during panel fabrication and finishing.

PART 3 EXECUTION

Specifier Note: Article below is an addition to the CSI SectionFormat and a supplement to MANU-SPEC. Revise Article below to suit project requirements and specifier's practice.

3:01 MANUFACTURER'S INSTRUCTIONS

A. Compliance: Comply with manufacturer's product data, recommendations and installations instructions for substrate verification, preparation requirements and installation.

1. Strippable Film: Remove manufacturer's protective film, if any, from surfaces of roofing panels.

3:02 EXAMINATION

A. Site Verification of Conditions: Verify substrate conditions, which have been previously installed under other sections, are acceptable for project installation in accordance with manufacturer's instructions.

3:03 PREPARATION

A. Coordination: Coordinate metal roofing with other Work (drainage, flashing and trim, deck substrates, parapets, copings, walls) and other adjoining work to provide a non-corrosive and leak-proof installation.

B. Dissimilar Metals: Prevent galvanic action of dissimilar metals.

Specifier Note: Coordinate article below with manufacturer's recommended installation details.

3:04 INSTALLATION

A. General: Install metal roofing panels to profiles, patterns and drainage indicated and required for leak-proof installation. Provide for structural and thermal movement at work. Seal joints for leak-proof installation.

1. Seams: Provide uniform, neat seams.
2. Fasteners: Conceal fasteners where possible in exposed work. Cover and seal fasteners and anchors for watertight and leak-proof installation.
3. Sealant-Type Joints: Provide sealant-type joint where indicated. Form joints to conceal sealant. Comply with Division 7 Joint Sealants Section for Sealant installation.

3:05 FIELD QUALITY REQUIREMENTS

A. Site Tests (Post Installation Testing): Owner reserves right to perform post installation testing of installed sheet metal roofing.

Specifier Note: Edit paragraph below. Establish number and duration of periodic site visits with owner and Manufacturer and specify below. Consult with manufacturer for services required. Coordinate paragraph below with Division 1 Quality Assurance Section. Delete paragraph if manufacturer field services not required.

B. Manufacturer's Field Services: Upon Owner's request, provide manufacturer's field service consisting of product use recommendations and periodic site visit for inspection of product installation in accordance with manufacturer's instructions

3:06 CLEANING

A. Cleaning: Remove temporary coverings and protection of adjacent work areas. Repair or replace damaged installed products. Clean installed products in accordance with manufacturer's instructions prior to owner's acceptance. Remove construction debris from project site and legally dispose of debris.

3:07 PROTECTION

A. Protection: Protect installed product from damage during construction.

SECTION 07 71 23

GUTTERS AND DOWNSPOUTS

PART 1 GENERAL

1.01 REFERENCES

- A. General Conditions and Special Conditions of the Contract and Division 1 of the Specifications are a part of this Section as if stated in full herein.

1.02 SUMMARY

- A. Furnish and install gutter and downspout systems as shown on Drawings & Specified herein.

1.03 RELATED SECTIONS

- A. Section 06 10 00 - Rough Carpentry.
- B. Section 07 31 00 Shingles
- C. Section 07 92 00 Joint Sealers
- D. Section 07 46 10 Strand Substrate Siding & Trim.

1.04 SUBMITTALS

- A. Submit under provisions of Section 00 90 00.
- B. [Product Data]: Manufacturer's data sheets on each product to be used, including:
 - 1. Preparation instructions and recommendations.
 - 2. Storage and handling requirements and recommendations.
 - 3. Installation methods.
- C. Shop Drawings: Submit shop drawings of assemblies and systems components installed in the field.
- D. Color Selection Samples: For each application specified, two complete sets of color chips representing manufacturer's full range of available colors.

1.05 QUALITY ASSURANCE

- A. Manufacturer Qualifications:
 - 1. Gutter and downspout manufacturer to have minimum 5 years documented experience in the design and fabrication of roofing

specialties and accessories.

- B. Mock-Up: Provide a mock-up for evaluation of surface preparation techniques and application workmanship.
1. Finish areas designated by Architect.
 2. Do not proceed with remaining work until workmanship, color, and sheen are approved by Architect.
 3. Refinish mock-up area as required to produce acceptable work.

1.06 DELIVERY, STORAGE, AND HANDLING

- A. Store products in manufacturer's unopened packaging until ready for installation.

1.07 PROJECT CONDITIONS

- A. Do not install products under environmental conditions outside manufacturer's absolute limits.

1.08 WARRANTY

- A. Warrant products installed under this section of work to be free of defects in materials and/or manufacture for a period of 20 years

PART 2 PRODUCTS

2.01 MANUFACTURERS

- A. Acceptable Manufacturer: Berger Building Products, Inc., which is located at: 805 Pennsylvania Blvd. ; Feasterville, PA 19053; Toll Free Tel: 800-523-8852; Tel: 215-355-1200; Fax: 215-355-7738; Email: request info; Web: www.bergerbuildingproducts.com
- B. Requests for substitutions will be considered in accordance with provisions of Section 00 20 00.

2.02 GUTTER AND DOWNSPOUT SYSTEMS

- A. Downspouts/Conductors
- a. 3" x 4" Downspouts
 - b. Corrugated
 - c. Painted finish aluminum
- B. Gutter Profiles:
1. Size: 5"
 2. "K" Style Gutter System:
 - a. Painted finished aluminum
 3. Roof Edge:
 - a. See 07 60 00.

PART 3 EXECUTION

3.01 EXAMINATION

- A. Do not begin installation until the roofing has been completely installed.

3.02 INSTALLATION

- B. Install materials in accordance with manufacturer's printed instructions.

3.03 PROTECTION

- A. Protect installed products until completion of project.
- B. Touch-up, repair or replace damaged products before Substantial Completion.

END OF SECTION

SECTION 07 72 26

RIDGE AND SOFFIT VENTS

PART 1 GENERAL

1.01 REFERENCES

- A. General Conditions and Special Conditions of the Contract and Division 1 of the Specifications are a part of this Section as if stated in full herein.

1.02 SUMMARY

- A. Ridge vents and accessories.
- B. Soffit vents.

1.03 RELATED SECTIONS

- A. Section 06 10 00 - Rough Carpentry.
- B. Section 07 31 00 - Roof Shingles and Shakes.

1.04 REFERENCES

- A. ICC-ES Report ESR-2664 August 1, 2008.
- B. ANSI/UL 790 - Tests for Fire Resistance of Roof Covering Materials.

1.05 SUBMITTALS

- A. Submit: Manufacturer's data sheets on each product to be used, including:
 - 1. Preparation instructions and recommendations.
 - 2. Storage and handling requirements and recommendations.
 - 3. Installation methods.

1.06 QUALITY ASSURANCE

- A. Trimline Ridge Vents were tested and passed all tests for weather infiltration as follows:
 - 1. ICC-ES Report ESR-2664.
 - 2. Miami-Dade County, Florida, NOA No. 07-0124.09.
 - 3. Florida Certificate of Product Approval # FL4330.
 - 4. TDI Evaluated RV-21.

5. ANSI/UL 790, Class A or C as to an external fire exposure only when installed in accordance with instructions provided with ridge vents 8FA1.
- B. Verification Samples: For each finish product specified, two full size samples representing actual product, color, and patterns.
- C. Manufacturer's Certificates: Certify products meet or exceed specified requirements.

1.07 DELIVERY, STORAGE, AND HANDLING

- A. Store products in manufacturer's unopened packaging until ready for installation.
- B. Maintain dry storage area for products of this section until installation of products.

1.08 PROJECT CONDITIONS

- A. Maintain environmental conditions within limits recommended by manufacturer for optimum results. Do not install products under environmental conditions outside manufacturer's absolute limits.

PART 2 PRODUCTS

2.01 MANUFACTURERS

- A. Acceptable Manufacturer: Company; Trimline Building Products, an LDI Company, 705 Pennsylvania Ave., Minneapolis, MN 55426. ASD. Toll Free: (800) 438-2920, Tel: (763) 540-9700, Fax: 763-540-9709, Email: info@trimline-products.com.
- B. Substitutions: The following substitution will be permitted.
 1. Owens Corning VentSure Rigid Roll with Weather PROtector Membrane.
- C. Requests for substitutions will be considered in accordance with provisions of Section 00 20 00.

2.02 MATERIALS

- A. Ridge Vents: Trimline Ridge Roll Plus One Pass Installation, a corrosion-free, laminated high-density polyethylene corrugated plastic with a thin spun bound non-absorbent polypropylene membrane bonded to it not permitting direct water or weather entry. Layers of corrugated product must be z-folded

and glued, not stapled. Product backed by lifetime manufacturer's warranty and capable of being used on applications with pitches from 3/12 to 20/12.

1. Ridge Vents: Trimline High Profile Rigid Vent Plus with StormStop.
 - a. Net Free Area: 19 inches (483 mm) per lineal foot.
 - b. Color: Black.
 - c. Dimensions: 11-1/4 inches (283 mm) wide by 4 feet (1.2 m) long by 1 inch (25 mm) high.
- B. Soffit Vents: 18 x 14 bronze woven mesh hardware cloth as manufactured by TWP, Inc., or approved equal, 18 x 14 mesh bronze .011" wire diameter with lacquered clear coat finish.

PART 3 EXECUTION

3.01 EXAMINATION

- A. Do not begin installation until roof openings and substrates have been properly prepared.
- B. Verify deck surfaces are correctly framed, dry, free of ridges, warps, or voids.
- C. If openings and substrate preparation is the responsibility of another installer, notify Architect of unsatisfactory preparation before proceeding.

3.02 INSTALLATION

- A. General: Install in accordance with manufacturer's instructions.
- B. Ridge Vents:
 1. Place vent over the entire length of the ridge vent opening. Butt separate pieces tightly together.
 2. Install end caps at both ends of the ridge vent.
 3. Secure cap shingles and vents at the same time by nailing ridge caps with roofing nails in a common overlapping pattern. Nails should penetrate the wood deck a minimum of 1/2 inch (12.5 mm). Position ridge vent to maintain the pitch of the roof before nailing.
- C. Soffit Vents:
 1. Install continuous vents along full length of soffit as shown on Drawings unless otherwise noted.

3.03 PROTECTION

- A. Protect installed products until completion of project.
- B. Repair or replace damaged products before Substantial Completion.

END OF SECTION

SECTION 07 84 00 FIRESTOPPING

PART 1 GENERAL

1.01 REFERENCES

- A. General Conditions and Special Conditions of the Contract and Division 1 of the Specifications are a part of this Section as if stated in full herein.
- B. Test standards for evaluating and rating the performance of firestop designs:
 - 1. ASTM E 814, Standard Method of Fire Tests of Through-Penetration Firestops.
 - 2. UL 1479, Fire Tests of Through-Penetration Firestops.
- C. Firestop design classification references:
 - 1. UL Fire Resistance Directory: Through-Penetration Firestop devices (XHCR) and Through-Penetration Firestop Systems (XHEZ).
 - 2. Factory Mutual Approval Guide.
 - 3. ULC List of Equipment and Materials, Vol. II.
 - 4. Other agencies or jurisdictional authorities which publish design performance or design evaluation services, e.g. CABO, BOCA, ICBO, SBCCI, Warnock Hersey, SwRI, shall be acceptable.

1.02 SCOPE OF WORK

- A. Perform all work required, and furnish all materials necessary to complete proper installation of firestops in fire rated walls and partitions, or fire rated floors, around penetrations of pipe, duct, cable, conduit and other electrical devices, or in blank openings, as indicated by the Drawings.
- B. Firestopping work shall be performed by a single installer or subcontractor to maintain consistency and accountability on the Project.

1.03 DEFINITIONS

- A. Fire Rated: Having the ability to withstand the effects of fire for a specified time period, as determined by qualified testing.
- B. Fire Rated Assembly: A floor, wall, or other partition able to withstand a design fire and hose stream test without failure.
- C. Fire Resistance Rating: The time, in hours, for which the rated assembly can withstand the effects of fire without burn-through or structural failure.
- D. Firestop: A means of sealing openings in fire rated assemblies to preserve or restore the fire resistance rating.
- E. Firestop System: The combination of materials and/or devices, including the penetrating items, required to make up a complete firestop.

- F. Penetrating Item: A pipe, duct, conduit, cable tray, cable, or other element passing through an opening in a fire rated assembly.

1.04 SUBMITTALS

- A. Submit manufacturer's technical data for each product which includes, at a minimum, product description, specification and storage requirements.
- B. Submit firestop design basis documents.
- C. Submit product installation procedures and requirements.
- D. Submit Materials Safety Data Sheets with product delivered to jobsite.

1.05 QUALITY ASSURANCE

- A. Workmanship:
 - 1. Installation shall conform to requirements of qualified design or manufacturer approved modification, as supported by engineering reports.
 - 2. Exposed surfaces of the firestop shall be finished to the standard of the adjacent faces of the partition being penetrated.
- B. Regulatory Requirements:
 - 1. Firestop systems shall be installed in all openings and around all penetrating elements or devices as required by these Specifications, and as required by applicable design, building and construction codes, subject to the interpretation of the authority having jurisdiction.
- C. Certification:
 - 1. The performance of the firestop designs shall have been demonstrated by third party testing in accordance with the applicable reference standards of Article 1.01. Evidence of third-party acceptance shall include labeling or listing by an acceptable agency.
 - 2. Manufactured assemblies and material formulations shall be prepared under a third party monitored Quality Control Program, e.g., UL Followup Service.
 - 3. Contractor shall certify compliance with the provisions of this Section.

1.06 DELIVERY, STORAGE, AND HANDLING

- A. Deliver materials to the site in original unopened containers or bags bearing the name of the manufacturer, product name, type, grade and UL Classification Mark (or other acceptable approval or listing mark) where applicable.
- B. Coordinate delivery of materials with scheduled installation date to allow minimum storage time at jobsite.
- C. Storage of products shall comply with manufacturer's requirements for each product.
- D. Comply with recommended procedures, precautions or remedies described in Material Safety Data sheets as applicable.

1.07 SEQUENCING AND SCHEDULING

- A. Firestopping requirements may be created by other trades under related sections of the Project Specification. Contractor shall:
 - 1. Identify all locations requiring firestopping.
 - 2. Schedule installation of firestopping after completion of duct, piping, electrical runs, but prior to covering or concealing of openings or eliminating access thereto.

PART 2 PRODUCTS

2.01 ACCEPTABLE MANUFACTURERS

- A. Nelson Firestop Products, a Unit of General Signal.
- B. 3M Fire Protection Products
- C. Hilti Firestop Products
- D. Tremco, Inc.

2.02 MATERIALS

- A. Firestop material shall be a ready to use, permanently pliable intumescent putty, or caulk.
- B. Material shall have not less than a 2 hour fire rating.
- C. Technical requirements:
 - 1. Designs selected for installation shall provide a fire resistance rating at least equal to the hourly resistance rating of the wall or partition into which the firestop design will be installed.
 - 2. Firestop systems and materials shall not require special tools for installation and shall not emit hazardous, combustible or irritating fumes during installation, curing or use.
 - 3. When more than one firestop design is applicable, individual product characteristics should be evaluated for secondary benefits in performance, e.g. environmental/water sealing, or ease of installation or modification.

PART 3 EXECUTION

3.01 EXAMINATION

- A. Verify that all penetrating elements and supporting devices have been installed and all temporary lines have been removed.

3.02 PREPARATION

- A. Provide drop cloths or other satisfactory covering for protection of adjacent areas in accordance with good work practices.

- B. Surfaces which will be in contact with penetration seal materials shall be clean and free of dust, dirt, grease, oil, loose materials, rust or other substances.

3.03 INSTALLATION

- A. Install penetration seal materials in accordance with design requirements and manufacturer's instructions.
- B. Follow design requirements pertaining to cable separation.
- C. Follow manufacturer's recommendations to obtain a smooth, professional finish.
- D. If forms or damming materials are installed, they shall be removed after the designated cure time unless the support materials used are of a fire resistant or noncombustible nature.

3.04 REPAIRS AND MODIFICATIONS

- A. Identify damaged or re-entered seals requiring repair or modification.
- B. Remove loose or damaged materials.
- C. If penetrating elements are to be added, remove enough material to insert new elements, being careful not to cause damage to the balance of the seal.
- D. Insure that surfaces to be sealed are clean and dry.
- E. Install materials in accordance with Article 3.03 as required. Use only materials approved by manufacturer as suitable for repair of original seal.

3.05 FIELD QUALITY CONTROL

- A. Examine penetration seals for proper installation, adhesion and curing as may be appropriate for the respective seal materials.
- B. Keep areas of work accessible and notify code authorities or designated inspectors of work released for inspection.
- C. Document completion and inspection as required.

3.06 CLEAN-UP

- A. Remove equipment, materials, and debris, leaving area in a clean, undamaged condition.

END OF SECTION

SECTION 07 92 00 JOINT SEALANTS

PART 1 GENERAL

1.01 REFERENCES

- A. General Conditions and Special Conditions of the Contract and Division 1 of the Specifications are a part of this Section as if stated in full herein.

1.02 SUMMARY

- A. Throughout the work, seal and caulk joints where shown on the Drawings and elsewhere as required to provide a positive barrier against passage of moisture and passage of air.

1.03 QUALITY ASSURANCE

- A. Use adequate numbers of skilled workmen who are thoroughly trained and experienced in the necessary craft and who are completely familiar with the specified requirements and the methods needed for proper performance of the work of this Section.

1.04 SUBMITTALS

- A. Materials list of items proposed to be provided under this Section;
- B. Manufacturer's specifications and other data needed to prove compliance with the specified requirements;
- C. Manufacturer's recommended installation procedures which, when approved by the Architect, will become the basis for accepting or rejecting actual installation procedures used on the work.
- D. Samples: Accompanying the submittal described above, submit Samples of each sealant, each backing material, each primer, and each bond breaker proposed to be used.

1.05 DELIVERY, STORAGE, AND HANDLING

- A. Deliver products in manufacturer's original packaging with labels intact.
- B. Handle and store products in a manner to prevent damage.
- C. Do not retain at the job site material which has exceeded the shelf life recommended by its manufacturer.

PART 2 PRODUCTS

2.01 SEALANTS

- A. Except as specifically otherwise approved by the Architect, use only the types of sealants specified.
- B. Application and Sealant Required:
 - 1. Concrete sidewalk joints: Sonneborn, Sonolastic SL1 (one-part self-leveling polyurethane) or SL2 (two-part polyurethane sealant for horizontal joint); or Tremco Vulkem 45 SSL (one-part polyurethane).
 - 2. Joints between surface applied reglets and umbrella flashings and other materials: Sonneborn, Sonolastic NP 1 (one part) polyurethane; or Tremco Vulkem 116 (one-part polyurethane).
 - 3. Control joints in masonry: Sonneborn, Sonolastic 150, one part silyl-terminated non-sag elastomeric sealant.
 - 4. Interior perimeter joints between metal and/or hollow metal door and window frames and adjacent materials, and other joints indicated by drawings for caulk: Sonneborn, Sonolac (acrylic latex caulk); or Tremco Tremflex 834 (acrylic latex caulk).
 - 5. Exterior joints between metal items or between metal and masonry: Sonneborn, Omniseal (silicone sealant); or Tremco Spectrem 2 (silicone sealant).
- C. Colors for each sealant installation will be selected by the Architect from standard colors normally available from the specified manufacturers.
 - 1. In concealed installations, and in partially or fully exposed installations where so approved by Architect, use standard gray or black sealant.

2.02 PRIMERS

- A. Use only those primers which are non-staining, have been tested for durability on the surfaces to be sealed, and are specifically recommended for this installation by the manufacturer of the sealant used.

2.03 BACKER MATERIAL

- A. Use only those backer materials which are specifically recommended for this installation by the manufacturer of the sealant used, which are non-absorbent, and which are non-staining.
- B. Acceptable types include:
 - 1. Closed-cell resilient urethane or polyvinyl-chloride foam.
 - 2. Closed-cell polyethylene foam;
 - 3. Closed-cell sponge of vinyl or rubber;
 - 4. Polychloroprene tubes or beads;
 - 5. Polyisobutylene extrusions;
 - 6. Oil-less dry jute.

2.04 BOND-PREVENTATIVE MATERIALS

- A. Use only one of the following as best suited for the application, and as recommended by the manufacturer of the sealant used:
 - 1. Polyethylene tape, pressure-sensitive adhesive, with the adhesive required only to hold tape to the construction materials as indicated;
 - 2. Aluminum foil complying with MIL-A-148E;
 - 3. Wax paper complying with Fed Spec UU-P-270.

2.05 MASKING TAPE

- A. For masking around joints, provide masking tape complying with Fed Spec UU-T-106c.

2.06 OTHER MATERIALS

- A. Provide other materials, not specifically described but required for a complete and proper installation, as selected by the Contractor subject to the approval of the Architect.

PART 3 EXECUTION

3.01 EXAMINATION

- A. Examine the areas and conditions under which work of this Section will be performed. Correct conditions detrimental to timely and proper completion of the work. Do not proceed until unsatisfactory conditions are corrected.

3.02 PREPARATION

- A. Concrete and masonry surfaces:
 - 1. Install only on surfaces which are dry, sound, and well brushed, wiping free from dust.
 - 2. At open joints, remove dust by mechanically blown compressed air if so required.
 - 3. Use solvent to remove oil and grease, wiping the surfaces with clean rags.
 - 4. Where surfaces have been treated, remove the surface treatment by sandblasting or wire brushing.
 - 5. Remove laitance and mortar from joint cavities.
 - 6. Where backup is required, insert the approved backer material into the joint cavity to the depth needed.
- B. Steel surfaces:
 - 1. Steel surfaces in contact with sealant:
 - a. Sandblast as required to achieve acceptable surface for bond.
 - b. If sandblasting is not practical, or would damage adjacent finish, scrape the metal or wire brush to remove mill scale.
 - c. Use solvent to remove oil and grease, wiping the surfaces with clean rags.

2. Remove protective coatings on steel by sandblasting or by using a solvent which leaves no residue.
- C. Aluminum surfaces:
1. Aluminum surfaces in contact with sealant:
 - a. Remove temporary protective coatings, dirt, oil and grease.
 - b. When masking tape is used for protective cover, apply the tape just prior to applying the sealant.
 2. Use only such solvents to remove protective coatings as are recommended for that purpose by the manufacturer of the aluminum work, and which are non-staining.
- D. Wood and composite wood surfaces:
1. Install only on surfaces which are dry, sound, and free from dust.
 2. At open joints, remove dust by mechanically blown compressed air if so required.
 3. Where backup is required, insert the approved backer material into the joint cavity to the depth needed.

3.03 INSTALLATION OF BACKER MATERIAL

- A. Use only the backer material recommended by the manufacturer of the sealant used for the particular installation, compressing the backer material 25% to 50% to achieve a positive and secure fit.
- B. When using backer of tube or rod stock, avoid lengthwise stretching of the material. Do not twist or braid hose or rod backer stock.

3.04 PRIMING

- A. Use only the primer recommended by the manufacturer of the sealant for the particular installation, applying in strict accordance with the manufacturer's recommendations as approved by the Architect.

3.05 BOND-BREAKER INSTALLATION

- A. Install an approved bond-breaker where recommended by the manufacturer of the sealant adhering strictly to the installation recommendations as approved by the Architect.

3.06 INSTALLATION OF SEALANTS

- A. Prior to start of installation in each joint, verify the joint type according to details on the Drawings, or as otherwise directed by the Architect, and verify that the required proportion of width of joint to depth of joint has been secured.

- B. Equipment:
 - 1. Apply sealant under pressure with power-actuated or hand gun, or by other appropriate means.
 - 2. Use guns with nozzle of proper size, and providing sufficient pressure to completely fill the joints as designed.
- C. Thoroughly and completely mask joints where the appearance of sealant on adjacent surfaces would be objectionable.
- D. Install the sealant in strict accordance with the manufacturer's recommendations thoroughly filling joints to the recommended depth.
- E. Tool joints to the profile shown on the Drawings, or as otherwise required if such profiles are not shown on the Drawings.

3.07 CLEANING UP

- A. Remove masking tape immediately after joints have been tooled.
- B. Clean adjacent surfaces free from sealant as the installation progresses, using solvent or cleaning agent recommended by the manufacturer of the sealant used.

END OF SECTION

DIVISION 8 OPENINGS

SECTION 08 11 00 STEEL DOORS AND FRAMES

PART 1 GENERAL

1.01 REFERENCES

- A. General Conditions and Special Conditions of the Contract and Division 1 of the Specifications are a part of this Section as if stated in full herein.

1.02 SUMMARY

- A. Furnish and install steel doors and frames as indicated on the Drawings.
- B. Related Sections:
 - 1. Section 08 70 00 - Hardware.
 - 2. Section 08 80 00 - Glazing.

1.03 SUBMITTALS

- A. Submit shop drawings and manufacturer's information on doors, frames, and hardware preparation.

1.04 DELIVERY, STORAGE, AND HANDLING

- A. Store steel doors and frames under cover and protected from the weather.

PART 2 PRODUCTS

2.01 MANUFACTURERS

- A. Republic Steel Corporation
- B. Western Hollow Metal
- C. Amweld
- D. Mesker Door, Inc.
- E. Steelcraft
- F. Ceco Door Products

2.01 HOLLOW METAL DOORS

- A. Full-flush doors with flat and seamless steel face skins welded to internal steel channel stiles and rails, and with following requirements:
 - 1. Minimum thickness for face skins: 16 gauge.
 - 2. Insulating core for all doors: Structural foam.
 - 3. Cap doors, top and bottom, and weld. Fill and grind smooth all edge seams.
 - 4. Finish: Phosphatized and one coat rust-resisting baked-on prime paint.
 - 5. Mortise and reinforce for hardware.
 - 6. Glazed panels: As indicated on the Drawings.
 - 7. Cores for fire-rated doors: as required for labeling conditions.
 - 8. Label: Underwriters Lab Labels as required by the Door Schedule.

2.03 HOLLOW STEEL FRAMES

- A. Formed as indicated, with mitered and welded corners flush and smooth, and with the following requirements:
 - 1. Minimum gauge: 14 gauge.
 - 2. Finish: phosphatized and one coat rust-resistive baked-on prime paint.
 - 3. Mortise and reinforce for finish hardware. Cover hinge reinforcements and strike plate cutouts with plaster guard.
 - 4. Removable center mullion on pairs of doors where indicated. Astragals on pairs of doors and other special devices indicated or required.
 - 5. Floor anchor and three (3) adjustable anchors per jamb for openings to 7'-2" high; additional anchors for taller frames.
 - 6. Rubber silencer pads.
 - 7. Provide sidelight, transom, and interior borrowed light frames with steel stops as shown on the Drawings.
 - 8. Label: Underwriter's Lab Label as required by the Door Schedule.
 - 9. Stainless steel cased opening frames at openings 99 & 100.

PART 3 EXECUTION

3.01 INSTALLATION

- A. Install per approved shop drawings and manufacturer's directions.
- B. Frame spreaders at the base of hollow metal frames are usually provided only for stability during shipping. Do not rely on spreaders as a gauge of required door width.
- C. At all exterior locations, all concealed surfaces inside the frame shall be thoroughly covered with a coating of fibrated asphalt coating, prior to installation.

END OF SECTION

SECTION 08 31 00 ACCESS DOORS

PART 1 GENERAL

1.01 REFERENCES

- A. General Conditions and Special Conditions of the Contract and Division 1 of the Specifications are a part of this Section as if stated in full herein.

1.02 SUMMARY

- A. Furnish and install steel access doors and frames to utility spaces as indicated on the Drawings.

1.03 SUBMITTALS

- A. Submit shop drawings and manufacturer's information on doors, frames, and wall preparation.

1.04 DELIVERY, STORAGE, AND HANDLING

- A. Store access doors and frames under cover and protected from the weather.

PART 2 PRODUCTS

2.01 MANUFACTURERS

- A. Larsen's Manufacturing Company
- B. Karp Associates, Inc.
- C. Milcor, Inc.
- D. Williams Brothers Corporation

2.02 PRODUCT DESCRIPTION

Larsen's, Insulated exterior access panel, L-XT series

- A. Size: As indicated on the Drawings.
- B. Fire Rating: As indicated on the Drawings.
- C. Finish: Phosphate- dipped steel with prime coat.
- D. Frame and Trim: .080 6063-T5 extruded aluminum, 2 3/8 inch wide with anchors appropriate for the wall material in which it will be mounted.
- E. Door: aluminum (mill finish)

- F. Foam Insulation: 2 ¼ lb. density, 6.5 R value
- G. Gaskets: Extruded Santoprene
- H. Hinges: Continuous s.s. piano hinge
- I. Latch: Key operated chrome plated steel handle.

PART 3 EXECUTION

3.01 INSTALLATION

- A. Install per approved shop drawings and manufacturer's directions.
- B. Coordinate with placing of masonry or stud walls to assure secure anchorage of access door frames.

END OF SECTION

SECTION 08 80 00 GLAZING

PART 1 GENERAL

1.01 REFERENCES

- A. General Conditions and Special Conditions of the Contract and Division 1 of the Specifications are a part of this Section as if stated in full herein.
- B. Flat Glass Marketing Association:
 - 1. Glazing Manual.
 - 2. Glazing Sealing System Manual.

1.02 SUMMARY

- A. Provide glazing and glazing accessories where shown on the Drawings, as specified herein, and as needed for a complete and proper installation.

1.03 SUBMITTALS

- A. Submit product data as follows:
 - 1. Materials list of items proposed to be provided under this Section;
 - 2. Manufacturer's specifications and other data needed to prove compliance with the specified requirements;
 - 3. Manufacturer's recommended installation procedures which, when approved by the Architect, will become the basis for accepting or rejecting actual installation procedures used on the work.
- B. Samples: Accompanying the above product data, submit:
 - 1. Samples of each type of glass and gasket proposed to be used;
 - 2. Samples, at least 12" long, of each type of sealant proposed to be used, installed between samples of the material to be glazed, fully cured.

1.04 QUALITY ASSURANCE

- A. Use adequate numbers of skilled workmen who are thoroughly trained and experienced in the necessary crafts and who are completely familiar with the specified requirements and the methods needed for proper performance of the work of this Section.

1.05 DELIVERY, STORAGE, AND HANDLING

- A. During storage and handling of glass, provide cushions at edges to prevent impact damage.

PART 2 PRODUCTS

2.01 GLASS

- A. General:
 - 1. For all glass, provide the type and thickness shown on the Drawings or specified herein.
 - 2. Where type or thickness, or both, are not shown on the Drawings or specified herein, provide type and thickness directed by the Architect.
- B. Plate or Float Glass: Comply with Fed.Spec DD-G-451, Type I, Class 1, Quality q3.2. Where plate glass is called for, plate glass or float glass may be used.
- C. Sheet Glass: Provide Type II, Class 1, Quality q5.

D. Tempered Glass:

1. Provide tempered or heat-strengthened glass where indicated on the Drawings, and elsewhere as required by governmental agencies having jurisdiction.
2. Glass for Tempering:
 - a. For plate glass or float glass, use Type I, Class 1, Quality q3.
 - b. For heat absorbing glass, if required, use Type I, Class 2, Type B, in color as shown on the Drawings or otherwise selected by the Architect.
3. Sizes and Cutting:
 - a. Prior to tempering or heat treating, cut glass to required sizes as determined by accurate measurements of the openings to be glazed, making allowances for required edge clearances.
 - b. Cut and process edges in accordance with the glass manufacturer's recommendations.
 - c. Do not cut or treat edges in the field.
4. Fully Tempered Glass:
 - a. Comply with Fed Spec DD-G-1403 and ANSI Z97.1.
 - b. Wherever possible, locate tong marks along an edge which will be concealed in the glazing system.
 - c. Permit minimum warpage practicable.
5. Heat-strengthened Glass:
 - a. Comply with Fed Spec DD-G-1403.
 - b. Strengthen by the manufacturer's standard heat-treating process, increasing flexural strength to not less than twice the strength before treatment.
 - c. Permit minimum warpage practicable.

E. Specific Glass Types:

1. Insulating Tinted:
 - a. 1" insulating glass composed of 1/4" PPG Solar bronze at exterior and 1/4" clear at interior.
 - b. Aesthetic appearance: LIGHT BRONZE
 - c. Performance:

Transmittance, total solar energy	33%
U-Value, Winter Night	.48
U-Value, Summer Day	.57
Shading Coefficient	.52
Solar Heat Gain Coefficient	.45

Tempered as required
2. 1/4" tempered clear glass (typical at interior aluminum doors and sidelights at vestibules).
3. 1/4" Clear Plate (typical at interior doors).
4. 1/4" Fire Glass shall be Firelite Plus by Hippon Electric Glass, or approved equal.
5. 1/4" Mirror shall be mechanically attached w/ all edges ground smooth.
6. Mirror Pane (2 way glass) shall be 1/4" mirror reflective glass with reflective No. 1 surface classroom side of window.

2.02 OTHER MATERIALS

- A. Provide other materials, not specifically described but required for a complete and proper installation, as selected by the Contractor subject to the approval of the Architect.

PART 3 EXECUTION

3.01 EXAMINATION AND PREPARATION

- A. Examine the areas and surface conditions under which work of this Section will be performed. Correct conditions detrimental to timely and proper completion of the Work. Do not proceed until unsatisfactory conditions are corrected.
- B. Clean glazing channels, stops, and rabbets to receive the glazing materials, making free from obstruction and deleterious substances which might impair the work.
 - 1. Remove protective coating which might fail in adhesion or interfere with bond of sealants.
 - 2. Comply with manufacturer's instructions for final wiping of surfaces immediately prior to application of primer and glazing compounds or tapes.
 - 3. Prime surfaces to receive glazing compounds in accordance with manufacturer's recommendations.

3.02 INSTALLATION

- A. Inspect each piece of glass immediately prior to start of installation.
 - 1. Do not install items which are improperly sized, have damaged edges, or are scratched, abraded, or damaged in any other manner.
 - 2. Do not remove labels from glass until so directed by the Architect.
- B. Locate setting blocks at sills one quarter of the width of the glass in from each end of the glass, unless otherwise recommended by the glass manufacturer.
 - 1. Use blocks of proper size to support the glass in accordance with the manufacturer's recommendations.
 - 2. Provide spacers for all glass sizes larger than 50 united inches, to separate glass from stops; except where continuous glazing gaskets or felts are provided.
 - a. Locate spacers no more than 24" apart, and no closer than 12" to a corner.
 - b. Place spacers opposite one another.
 - c. Make bite of spacer on glass 1/4" or more.
- C. Set glass in a manner which produces the greatest possible degree of uniformity in appearance.
- D. Do not use two different glazing materials in the same joint system unless the joint used is approved in advance by the Architect.
- E. Mask, or otherwise protect, surfaces adjacent to installation of sealants.
- F. Miter-cut and seal the joints of glazing gaskets in accordance with the manufacturer's recommendations, to provide watertight and airtight seal at corners and other locations where joints are required.

3.03 PROTECTION

- A. Protect glass from breakage after installation by promptly installing streamers or ribbons, suitably attached to the framing and held free from glass. Do not apply warning markings, streamers, ribbons, or other items directly to the glass except as specifically directed by the Architect.

END OF SECTION

DIVISION 9 FINISHES

SECTION 09 21 16 GYPSUM BOARD ASSEMBLIES

PART 1 GENERAL

1.01 REFERENCES

- A. General Conditions and Special Conditions of the Contract and Division 1 of the Specifications are a part of this Section as if stated in full herein.

1.02 SUMMARY

- A. Furnish and install gypsum drywall assemblies for interior finishing and related items required to complete the work indicated on the Drawings and herein specified, or both.
- B. For steel studs and accessories refer to Section 05 40 00.

1.03 SUBMITTALS

- A. Submit a one foot long sample of each casing bead, "L" bead, expansion joint, bull nose corner bead, and corner bead for approval.
- B. Submit manufacturer's data for each type of gypsum board.

1.04 QUALITY ASSURANCE

- A. The Contractor shall coordinate the work between the trades to insure compliance with the Specifications, and to permit orderly and expeditious procedure in executing the work.
- B. Workmanship: Installation and taping of drywall interior finish shall be done by qualified mechanics experienced in this craft and capable of rendering a satisfactory installation in every respect.
- C. Temperature Requirements:
 - 1. If gypsum wall board is installed in the winter, heat not less than 60° F shall be maintained in the structures at all times.
 - 2. Temperature shall be maintained during installation of board as well as during the taping process.

1.05 DELIVERY, STORAGE, AND HANDLING

- A. Deliver materials in manufacturer's original packages or bundles with name of manufacturer, type of material, and sizes clearly marked on the packaging and containers.
- B. Store materials above the ground, protected from the weather.

PART 2 PRODUCTS

2.01 MATERIALS

- A. Gypsum wall board shall be 5/8 and 1/2 inch thick x 48 inches wide as shown on the Drawings and as manufactured by U.S. Gypsum Company, Temple-Inland Forest Products Corporation, National Gypsum Company, or approved equal.
- B. Gypsum wall board in locations above ceilings shall be fire rated type X in thickness as detailed on Drawings x 48 inches wide with tapered edges as manufactured by U.S. Gypsum Company, Temple-Inland Forest Products Corporation, National Gypsum Company, or approved equal.
- C. Tape shall be cross-fibered, with chamfered edges feather thin, as recommended by the gypsum wall board manufacturer.
- D. Joint cement and topping cement shall be that approved product manufactured by, and recommended by, the gypsum wall board manufacturer.
- E. Fasteners: U. S. G. Type S Bugle Head screws.
- F. Adhesive for direct applications shall be per gypsum wall board manufacturer's recommendations.
- G. "MJ" casing beads, "L" beads, expansion joints, bull nose corner beads and corner beads shall be rigid PVC as manufactured by Alabama Metal Industries Corporation (800-366-2642).

PART 3 EXECUTION

3.01 EXAMINATION

- A. The Contractor shall examine the framing to which the gypsum board is to be applied. If any defects in alignment or blocking are noted which would not allow the installation of the gypsum board as set forth in the Specifications, the defects shall be corrected before the gypsum board installation is started. Commencement of work on the framing constitutes acceptance of the framing by the Contractor.

3.02 GYPSUM BOARD INSTALLATION

- A. To minimize end joints, use wall board of maximum practical length. End joints shall be staggered.
- B. Provide PVC edge trim where wall board edge abuts dissimilar material.
- C. All flat joints shall be reinforced with tape, cemented with joint cement and finished with topping cement as recommended by gypsum board manufacturer, to a smooth, invisible joint.

- D. Where joints are not exposed to view, all flat joints shall be reinforced with tape and cemented with joint cement (Fire Taped), or UL listed adhesive fire tape.
- E. All screws shall be slightly set and covered with topping cement so as to become invisible.
- F. Corners shall be constructed as follows unless otherwise shown on the Drawings.
 - 1. Inside corners shall be reinforced with tape folded to conform to adjoining surface to form straight true angle.
 - 2. Outside corners shall have PVC corner bead. PVC corner bead shall be concealed by at least two coats of compound.
- G. No cracked boards shall be accepted in any case. Boards with occasional marred surface or edge may be allowed, if in the judgment of the Architect, these boards can be patched with compound.
- H. After final coat of topping compound has dried, sand lightly to produce smooth finished surface. Final finish by spray application of a light knock down texture in areas scheduled to be painted.
- I. All ends of gypsum wall board shall occur over studs, joists, furring channels, or other firm support.

3.03 CLEAN-UP

- A. At the completion of the work, all areas shall be left in a clean and neat manner with debris removed. All stains and other foreign matter shall be cleaned from floors, trim, walls, and ceiling. All areas shall be left ready for painting.

END OF SECTION

SECTION 09 51 00 ACOUSTICAL CEILINGS

PART 1 GENERAL

1.01 REFERENCES

- A. General Conditions and Special Conditions of the Contract and Division 1 of the Specifications are a part of this Section as if stated in full herein.

1.02 SUMMARY

- A. Provide acoustical ceiling systems complete with all necessary components and accessories and install per manufacturer's directions.

1.03 QUALITY ASSURANCE

- A. Provide ceiling assemblies in manner to result in meeting or exceeding Noise Reduction Coefficients (NRC) and Ceiling Attenuation Class (CAC) ratings indicated and/or specified.

1.04 DELIVERY, STORAGE, AND HANDLING

- A. Deliver materials in manufacturer's original packaging. Protect from damage during transporting and handling.
- B. Store materials in a dry enclosure, protected from exposure to the sun, adverse weather conditions, and damaging fumes.

PART 2 PRODUCTS

2.01 ACOUSTICAL PANEL CEILINGS

- A. Ceiling Type "A" – Cortega lay-in panels, Item No. 770, mineral fiberboard, manufactured by Armstrong, or approved equal, with these minimum standards:
 - 1. Nominal Size: 24" x 24" x 5/8"
 - 2. Flame Spread: Class A (Flame Spread of 25 or less).
 - 3. Finish: white finish giving an average light reflectance of 0.82.
 - 4. NRC: 0.55
 - 5. CAC: 33
 - 6. Install in exposed grid system with low gloss white finish.
 - 7. Comparable products by USG Interiors, Inc. are acceptable.
- B. Ceiling Type "B" – Georgian (HumiGuard) lay-in panels, Item No. 764, manufactured by Armstrong, or approved equal with these minimum standards:
 - 1. Nominal Size: 24" x 24" x 5/8"
 - 2. Flame Spread: Class A (Flame Spread 25 or less)
 - 3. Finish: white giving an average light reflectance of 0.86 or greater.
 - 4. NRC Range: 55
 - 5. CAC Range: 33

6. Install in exposed aluminum grid system with low gloss white finish.
 7. Comparable products by USG Interiors, Inc. are acceptable.
- C. Suspension system shall be an exposed tee grid system, as manufactured by Donn Products, Inc., Westlake, Ohio, with exposed bottom flange. Tees shall form a 24" x 48" or 24" x 24" ceiling grid as required for specified lay-in units and be one of sufficient strength to carry imposed loads indicated on the Drawings and the fluorescent light fixtures. (Furnish grid with preformed inside and outside corners, bullnose where required.)
1. Other acceptable manufacturers: Chicago Metallic

PART 3 EXECUTION

3.01 INSTALLATION

- A. Consult drawings for layout of grid system and follow same throughout.
- B. Suspend main tees from supporting members with galvanized wire not smaller than 12 gauge at each supporting member. Tie around supporting member and through holes in tees and give each wire end three twists around self. Level, space and align main runners at 4' o.c.
- C. Provide additional 12 gauge wire hangers to support light fixtures.
 1. At each corner of 2' x 4' or larger fixtures.
 2. At each corner of fixtures where corners do not occur at regularly spaced hanger wires.
 3. Spaced not over 4' along sides of fixtures longer than 4' (or continuous run fixtures) where side does not occur over main runners.
- D. Install cross-tees of proper length at right angles to main runners to create a grid. Where recessed light fixtures, diffusers or other openings require same, place a cross tee.
- E. Under ducts or other obstructions, adjust as necessary to provide secure suspension system, maintaining grid layout.
- F. Provide channel or angle shape perimeter wall molding at level for proper ceiling height.
- G. Provide angle molding at ceiling drops and carry acoustical panels up drop face where necessary.
- H. Lay-in acoustical panels. Provide hold-down clips for panels in spaces having doors to the exterior.
- I. Protect openings for ducts and/or recessed light fixture.

END OF SECTION

SECTION 09651 - RESILIENT TILE FLOORING

PART 1 - GENERAL

1.1 SECTION REQUIREMENTS

- A. Submit Product Data and color Samples.
- B. Deliver to Owner at least 1 box for each 50 boxes or fraction thereof, of each type and color of resilient floor tile installed.

PART 2 - PRODUCTS

2.1 RESILIENT FLOOR TILE

- A. Armstrong, stock number 51899, "cool white"

PART 3 - EXECUTION

3.1 INSTALLATION

- A. Lay out tiles from center marks established with principal walls, discounting minor offsets, so tile widths at opposite edges of room are equal to one another and are at least one-half of a tile.
- B. Match tiles for color and pattern by selecting tiles from cartons in same sequence as manufactured and packaged. Lay tiles in basket-weave pattern with grain direction alternating in adjacent tiles.

END OF SECTION 09651

SECTION 09653 - RESILIENT WALL BASE AND ACCESSORIES

PART 1 - GENERAL

1.1 SECTION REQUIREMENTS

- A. Submit Product Data and color Samples.
- B. Deliver to Owner at least 10 linear feet (3 linear m) for each 500 linear feet (150 linear m) or fraction thereof, of each type and color of resilient wall base installed.

PART 2 - PRODUCTS

2.1 RESILIENT WALL BASE AND ACCESSORIES

- A. Armstrong World Industries, Kentile Floors, Roppe, or approved alternate.

PART 3 - EXECUTION

3.1 INSTALLATION

- A. Install wall base in maximum lengths possible.
- B. Apply resilient wall base to walls, columns, pilasters, casework, and other permanent fixtures in rooms or areas where base is required.
- C. Form wall base corners from straight pieces of maximum lengths possible.
- D. Install reducer strips at edges of flooring that otherwise would be exposed.

END OF SECTION 09653

**SECTION 09 67 23.30
RESIN (EPOXY RESIN COMPOSITION) MORTAR FLOORING (RES-3)**

PART 1 - GENERAL

1.1 DESCRIPTION

This section specifies a seamless resinous (epoxy resin composition) and aliphatic poly urethane sealer, flooring systems with integral cove base.

1.2 RELATED WORK

- A. Concrete and Moisture Vapor Barrier: Section 03 30 00, CAST-IN-PLACE CONCRETE.
- B. Color and location of each type of resinous (epoxy resin composition) flooring: Section 09 06 00, SCHEDULE FOR FINISHES.
- C. Floor Drains: Division 22, PLUMBING.

1.3 SUBMITTALS

- A. Submit in accordance with Section 01 33 23, SHOP DRAWINGS, PRODUCT DATA, AND SAMPLES.
- B. Manufacturer's Literature and Data:
 - 1. Description of each product to be provided.
 - 2. Application and installation instructions.
 - 3. Maintenance Instructions: Submit manufacturer's written instructions for recommended maintenance practices.
- C. Qualification Data: For Installer.
- D. Sustainable Submittal:
 - 1. Product data for products having recycled content, submit documentation indicating percentages by weight of postconsumer and pre consumer recycled content.
 - a. Include statements indicating costs for each product having recycled content, and low emitting materials.
 - 2. Product data for Environmental Quality Credit EQ 4.2 low emitting materials, include printed statement of VOC content indicating compliance with environmental requirements.
 - 3. Product data for Material Resource Credit MR 4.1, 12%-35% post-consumer recycled glass content.
- E. Samples:
 - 1. Each color and texture specified in Section 09 06 00, SCHEDULE FOR FINISHES.
 - 2. Samples for verification: For each (color and texture) resinous flooring system required, 6 inches (152 mm) square, applied to a rigid backing by installer for this project.

3. Sample showing construction from substrate to finish surface in thickness specified and color and texture of finished surfaces. Finished flooring must match the approved samples in color and texture.
- F. Shop Drawings: Include plans, sections, component details, and attachment to other trades. Indicate layout of the following:
 1. Patterns.
 2. Edge configuration
- G. Certifications and Approvals:
 1. Manufacturer's certification of material and substrate compliance with specification.
 2. Manufacturer's approval of installer
 3. Contractor's certificate of compliance with Quality Assurance requirements.
- H. Warranty: As specified in this section.

1.4 QUALITY ASSURANCE

- A. Manufacture Certificate: Manufacture shall certify that a particular resinous flooring system has been in use for a minimum of (5) five years.
- B. Installer Qualifications: Engage an experienced installer (applicator) who is experienced in applying resinous flooring systems similar in material, design, and extent to those indicated for this project for a minimum period of (5) five years, whose work has resulted in applications with a record of successful in-service performance, and who is acceptable to resinous flooring manufacturer.
 1. Engage an installer who is certified in writing by resinous flooring manufacturer as qualified to apply resinous flooring systems indicated.
 2. Contractor shall have completed at least (5) five projects of similar size and complexity. Include list of at least (5) five projects. List must include owner (purchaser); address of installation, contact information at installation project site; and date of installation.
 3. Installer's Personnel: Employ persons trained for application of specified product.
- C. Source Limitations:
 1. Obtain primary resinous flooring materials including primers, resins, hardening agents, grouting coats and finish or sealing coats from a single manufacturer.
 2. Provide secondary materials, including patching and fill material, joint sealant, and repair material of type and from source recommended by manufacturer of primary materials.

1.5 MATERIAL PACKAGING DELIVERY AND STORAGE

- A. Deliver materials to the site in original sealed packages or containers, clearly marked with the manufacturer's name or brand, type and color, production run number and date of manufacture.
- B. Protect materials from damage and contamination in storage or delivery, including moisture, heat, cold, direct sunlight, etc.
- C. Maintain temperature of storage area between 60 and 80 degrees F (15 and 26 degrees C).
- D. Keep containers sealed until ready for use.
- E. Do not use materials beyond manufacturer's shelf life limits.
- F. Package materials in factory pre-weighed and in single, easy to manage batches sized for ease of handling and mixing proportions from entire package or packages. No On site weighing or volumetric measurements are allowed

1.6 PROJECT CONDITIONS

- A. Environmental Limitations: Comply with resinous flooring manufacturer's written instructions for substrate temperature, ambient temperature, moisture, ventilation, and other conditions affecting resinous flooring applications.
 - 1. Maintain material and substrate temperature between 65 and 85 degrees F (18 and 30 degrees C) during resinous flooring application and for not less than 24 hours after application.
- B. Lighting: Provide permanent lighting or, if permanent lighting is not in place, simulate permanent lighting conditions during resinous flooring application.
- C. Close spaces to traffic during resinous flooring application and for not less than 24 hours after application, unless manufacturer recommends a longer period.
- D. Concrete substrate shall be properly cured for a minimum of 30 days. A vapor barrier must be present for concrete subfloors on or below grade. Otherwise, an osmotic pressure resistant grout must be installed prior to the resinous flooring.

1.7 WARRANTY

- A. Work subject to the terms of the Article "Warranty of Construction" FAR clause 52.246-21.
- B. Warranty: Manufacture shall furnish a single, written warranty covering the full assembly for both material and workmanship for a extended period of (3) full years from date of installation, or provide a joint and several warranty signed on a single document by manufacturer and applicator jointly and severally warranting the materials and workmanship for a period of (3) full years from date of installation. A

sample warranty letter must be included with bid package or bid may be disqualified.

1.8 APPLICABLE PUBLICATIONS

- A. The publication listed below form a part of this specification to the extent referenced. The publications are referenced in the text by the basic designation only.
- B. American Society for Testing and Materials (ASTM):
 - B221-08.....Standard Specification for Aluminum and Aluminum-Alloy, Extruded Bars, Rods, Wire, Profiles and Tubes.
 - C307-03 (2008).....Standard Test Method for Tensile Strength of Chemical-Resistant Mortar, Grouts, and Monolithic Surfacing
 - C413-01(2006).....Standard Test Method for Absorption of Chemical-Resistant Mortars, Grouts, Monolithic Surfacing and Polymer Concretes
 - C531-00(R2005).....Standard Test Method for Linear Shrinkage and Coefficient of Thermal Expansion of Chemical-Resistant Mortars, Grouts, Monolithic Surfacing and Polymer Concretes
 - C579-01(2006).....Standard Test Method for Compressive Strength of Chemical-Resistant Mortars, Grouts, Monolithic Surfacing, and Polymer Concretes
 - C580-02(2008).....Standard Test Method for Flexural Strength and Modulus of Elasticity of Chemical-Resistant Mortars, Grouts, Monolithic Surfacing, and Polymer Concretes
 - C811-98(2008).....Standard Practice for Surface Preparation of Concrete for Application of Chemical-Resistant Resin Monolithic Surfacing
 - D1308-02(2007).....Standard Test Method for Effect of Household Chemicals on Clear and Pigmented Organic Finishes
 - D2240-05.....Standard Test Method for Rubber Property - Durometer Hardness
 - D4060-07.....Standard Test Method for Abrasion Resistance of Organic Coatings by the Taber Abraser
 - D4226-09.....Standard Test Methods for Impact Resistance of Rigid Poly (Vinyl Chloride) (PVC) Building Products

- D7234-05.....Standard Test Method for Pull-Off Adhesion
Strength of Coatings on Concrete Using Portable
Pull-Off Adhesion Testers
- F1869-09.....Standard Test Method for Measuring Moisture
Vapor Emission Rate of Concrete Subfloor Using
Anhydrous Calcium Chloride
- F2170-09.....Standard Test Methods for Determining Relative
Humidity in Concrete Floor Slabs Using Situ
Probes

- C. National Association of Architectural Metal Manufacturers (NAAMM):
AMP 500-06.....Finishes for Aluminum

PART 2 - PRODUCTS

2.1 SYSTEM DESCRIPTION FOR RESINOUS FLOORING

A. System Descriptions:

- 1. Monolithic, multi-component epoxy chemistry, steel trowel applied resinous flooring mortar system, nominal 3/16"/5mm thick system comprised of a penetrating primer, multi component 100% solids epoxy mortar, grout coat sealer and clear VOC compliant, aliphatic polyurethane non-reflective finish.
- 2. Decorative quartz broadcast systems will not be accepted. Steel trowel finish mortars only

- B. Products: Subject to compliance with applicable fire, health, environmental, and safety requirements for storage, handling, installation, and clean up.

- C. System Components: Verify specific requirements as systems vary by manufacturer. Verify mortar base product, build up layers of broadcast systems will not be accepted. Verify compatibility with substrate. Use manufacturer's standard components, compatible with each other and as follows:

- 1. Primer (Bond) Coat: Verify inclusion of primer in manufacturer's system.
 - a. Resin: Epoxy.
 - b. Formulation Description: 100% solids.
 - c. Application Method: Apply by Squeegee and finish roller.
- 2. Mortar (Base) Coat: Verify mortar composition.
 - a. Resin: Epoxy.
 - b. Formulation Description: 100% solids, UV stable.
 - c. Application Method: Screed and steel finish trowel.
 - 1) Thickness of coat: Verify thickness as systems vary by manufacturer; approximately from 3/16 to 1/4 inch (4.76 to 6.35 mm).

- d. Aggregate: Pigmented color quartz silica, and a minimum or 12% recycled glass aggregates integral component to mortar.
 3. Grout Coat: Verify inclusion of base coat in manufacturer's system.
 - a. Resin: Epoxy.
 - b. Formulation Description: 100 percent solids, UV stable.
 - c. Application Method: Flat squeegee and roller applied.
 - d. Number of coats: (2) two, wet on wet application.
 4. Top (Seal) Coat: Verify inclusion of water based aliphatic polyurethane sealer coat as systems vary by manufacturer.
 - a. Resin: multi-component water based aliphatic polyurethane.
 - b. Formulation Description: High UV stability, stain and mar resistant. LEED compliant low V.O.C.
 - c. Application Method: Finish roller, dip into coating and back roll.
 - 1) Number of coats: (1) one
 - d. Aggregates: Optional if needed verify inclusion of slip-retardant aggregates in sealer coat.
- D. System Characteristics:
1. Color and Pattern: As selected by Owner from manufacturer's standard colors.
 2. Integral cove base: 1 inch (25.4 mm) radius epoxy mortar cove keyed into concrete substrate. Verify cove base installation with manufacturer's system.
 3. Overall System Thickness: Verify thickness as systems vary by manufacturer; between 3/16 inch (4.76 mm) and 1/4 inch (6.35 mm)
 4. Finish: anti-slip resistant to meet or exceed 0.06 dry; 0.08 wet.
- E. Physical Properties:
1. Physical Properties of flooring system when tested as follows:

Property	Test	Value
Compressive Strength	ASTM C579	7,500 psi after 7 days
Volatile Organic Compound Limits (V.O.C.)	EPA & LEED	Below 100 g/l
Tensile Strength	ASTM C307	1,750 psi
Flexural Modulus of Elasticity	ASTM C580	2,800 psi
Water Absorption	ASTM C413	0.1%
Slip Resistance Index	ASTM F1679	0.81 dry and 0.56 wet. Minimal levels
Impact Resistance	ASTM D4226	> 160 in. lbs
Abrasion Resistance	ASTM D4060 Cs-17 wheel, 1000 cycles	0.06 gm maximum weight loss
Thermal Coefficient of Linear Expansion	ASTM C531	1.3×10^{-5} mm/ °C mm
Hardness Shore D	ASTM D2240	85 to 90
Bond Strength	ASTM D7234	>300 psi 100% concrete failure
Chemical Resistance of the following: Betadyne stain resistance Acetic acid Ammonium hydroxide Citric Acid Fatty acid Motor Oil, 20W Hydrochloric acid Salt water Sodium Hydroxide Sulfuric acid Trisodium phosphate Urine Feces Hydrogen peroxide Distilled Water Sodium Hypochloride	ASTM D1380 5 percent 10 percent 50 percent 10 percent 10 percent 10 percent 10 percent 5 percent 28 percent 5.28 percent	No Effect

2.2 BASE CAP STRIP

- A. Aluminum, Extruded: ASTM B221, Alloy 6063-T6.
- B. Shape for 5 mm (3/16 inch) depth of base material, "J" configuration.
- C. Finish:
 1. Finish exposed surfaces in accordance with NAAMM Metal Finishes Manual.
 2. Aluminum: NAAMM Amp 500:
 - a. Clear anodic coating, AA-C22A41 chemically etched medium matte, with Architectural Class 1, 0.7 mils or thicker.

- b. Colored anodic coating, AA-C22A42, chemically etched medium matte with Architectural Class 1, 0.7 mils or thicker.

2.3 SUPPLEMENTAL MATERIALS

- A. Textured Top Coat: Type recommended or produced by manufacturer of seamless resinous flooring system, slip resistance type and profile
- B. Joint Sealant: Type recommended or produced by resinous flooring manufacturer for type of service or joint conditioned indicated.
- C. Waterproof Membrane: Type recommended or produced by manufacturer of resinous floor coatings for type of service and conditions as specified.
- D. Provide a chemical resistant epoxy novolac top coat capable of resisting sustained temperatures up to //120°C (250°F).
- F. Anti-Microbial Additive: Incorporate anti-microbial chemical additive to prevent growth of most bacteria, algae, fungi, mold, mildew, yeast, etc.

PART 3 - EXECUTION

3.1 INSPECTION

- A. Examine the areas and conditions where monolithic resinous flooring system with integral base is to be installed with the VA Resident Engineer.
- B. Moisture Vapor Emission Testing: Perform moisture vapor transmission testing in accordance with ASTM F1869 to determine the MVER of the substrate prior to commencement of the work. See section 3.4, 3.

3.2 PROJECT CONDITIONS

- A. Maintain temperature of rooms (air and surface) where work occurs, between 70 and 90 degrees F (21 and 32 degrees C) for at least 48 hours, before, during, and 24 hours after installation. Maintain temperature at least 70 degrees F (21 degrees C) during cure period.
- B. Maintain relative humidity less than 75 percent.
- C. Do not install materials until building is permanently enclosed and wet construction is complete, dry, and cured.
- D. Maintain proper ventilation of the area during application and curing time period.
 - 1. Comply with infection control measures of the VA Medical Center.

3.3 INSTALLATION REQUIREMENTS

- A. The manufacturer's instructions for application and installation shall be reviewed with the VA Resident Engineer for the seamless resinous flooring system with integral cove base //and trench liner//.
- B. Substrate shall be approved by manufacture technical representative.

3.4 PREPARATION

- A. General: Prepare and clean substrates according to resinous flooring manufacturer's written instructions for substrate indicated. Provide clean, dry, and neutral Ph substrate for resinous flooring application.
- B. Concrete Substrates: Provide sound concrete surfaces free of laitance, glaze, efflorescence, curing compounds, form-release agents, dust, dirt, grease, oil, and other contaminants incompatible with resinous flooring.
 - 1. Prepare concrete substrates as follows:
 - a. Shot-blast surfaces with an apparatus that abrades the concrete surface, contains the dispensed shot within the apparatus, and recirculates the shot by vacuum pickup.
 - b. Comply with ASTM C 811 requirements, unless manufacturer's written instructions are more stringent.
 - 2. Repair damaged and deteriorated concrete according to resinous flooring manufacturer's written recommendations.
 - 3. Verify that concrete substrates are dry.
 - a. Perform anhydrous calcium chloride test, ASTM F 1869. Proceed with application only after substrates have maximum moisture-vapor-emission rate of (5 lb of water/1000 sq. ft. (1.36 kg of water/92.9 sq. m) in 24 hours.
 - b. MVT threshold for monolithic resinous Non - climatic flooring shall not exceed 5 lbs/1000 square feet (0.0001437 kPa) in a 24 hour period. MVT threshold for monolithic resinous climatic flooring shall not exceed 6 lbs/1000 square feet (0.0002155 kPa) over a 24 hour period.
 - c. When MVT emission exceeds this limit, apply manufacturer's recommended vapor control primer or other corrective measures as recommended by manufacturer prior to application of flooring or membrane systems.
 - d. Perform in situ probe test, ASTM F2170. Proceed with application only after substrates do not exceed a maximum potential equilibrium relative humidity of 75-80 percent.
 - e. Provide a written report showing test placement and results.
 - 4. Verify that concrete substrates have neutral Ph and that resinous flooring will adhere to them. Perform tests recommended by manufacturer. Proceed with application only after substrates pass testing.
- C. Resinous Materials: Mix components and prepare materials according to resinous flooring manufacturer's written instructions.
- D. Use patching and fill material to fill holes and depressions in substrates according to manufacturer's written instructions.

- E. Treat control joints and other nonmoving substrate cracks to prevent cracks from reflecting through resinous flooring according to manufacturer's written recommendations. Allowances should be included for flooring manufacturer recommended joint fill material, and concrete crack treatment.
- F. Prepare wall to receive integral cove base
 - 1. Verify wall material is acceptable for resinous flooring application, if not, install material (e.g. cement board) to receive base.
 - 2. Fill voids in wall surface to receive base, install undercoats (e.g. water proofing membrane, and/or crack isolation membrane) as recommended by resinous flooring manufacturer.

3.5 APPLICATION

- A. **General:** Apply components of resinous flooring system according to manufacturer's written instructions to produce a uniform, monolithic wearing surface of thickness indicated.
 - 1. Coordinate application of components to provide optimum adhesion of resinous flooring system to substrate, and optimum inter-coat adhesion.
 - 2. Cure resinous flooring components according to manufacturer's written instructions. Prevent contamination during application and curing processes.
 - 3. At substrate expansion and isolation joints, provide joint in resinous flooring to comply with resinous flooring manufacturer's written recommendations.
 - a. Apply joint sealant to comply with manufacturer's written recommendations.
- B. Apply Primer: over prepared substrate at manufacturer's recommended spreading rate.
- C. Apply cove base: Trowel to wall surfaces at a 1 inch radius, before applying flooring. Apply according to manufacturer's written instructions and details including those for taping, mixing, priming, and troweling, sanding, and top coating of cove base. Round internal and external corners.
- D. Trowel mortar base: Mix mortar material according to manufacturer's recommended procedures. Uniformly spread mortar over substrate using a specially designed screed box adjusted to manufacturer's recommended height. Metal trowel hand or plastic blade power trowel, single mortar coat in thickness indicated for flooring system, Pre fill or grout to fill substrate voids. When cured, scrape or lightly stone mortar base to remove left unbounded material.

- E. Grout coat: Mix and roller apply the grout coats with strict adherence to manufacturer's installation procedures and coverage rates. (2) Two grout coatings to insure uniform coverage with wet on wet application.
- F. Topcoat: Mix and roller apply the topcoat(s) with strict adherence to manufacturer's installation procedures and coverage rates.

3.6 TOLERANCE

- A. From line of plane: Maximum 1/8 inch (3.18 mm) in total distance of flooring and base.
- B. From radius of cove: Maximum of 1/8 inch (3.18 mm) plus or 1/16-inch (1.59 mm) minus.

3.7 CURING, PROTECTION AND CLEANING

- A. Cure resinous flooring materials in compliance with manufacturer's directions, taking care to prevent contamination during stages of application and prior to completion of curing process.
- B. Close area of application for a minimum of 24 hours.
- C. Protect resinous flooring materials from damage and wear during construction operation.
 - 1. Cover flooring with kraft type paper.
 - 2. Optional 6 mm (1/4 inch) thick hardboard, plywood, or particle board where area is in foot or vehicle traffic pattern, rolling or fixed scaffolding and overhead work occurs.
- D. Remove temporary covering and clean resinous flooring just prior to final inspection. Use cleaning materials and procedures recommended by resinous flooring manufacturer.

- - - E N D - - -

SECTION 09 71 00 ACOUSTICAL WALL AND CEILING TREATMENT

PART 1 GENERAL

1.01 REFERENCES

- A. General Conditions and Special Conditions of the Contract and Division 1 of the Specifications are a part of this Section as if stated in full herein.

1.02 SUMMARY

- A. Provide acoustical wall and ceiling systems complete with all necessary components and accessories and install per manufacturer's directions.

1.03 QUALITY ASSURANCE

- A. Provide ceiling assemblies in manner to result in meeting or exceeding Noise Reduction Coefficients (NRC) of .40.

1.04 DELIVERY, STORAGE, AND HANDLING

- A. Deliver materials in manufacturer's original packaging. Protect from damage during transporting and handling.
- B. Store materials in a dry enclosure, protected from exposure to the sun, adverse weather conditions, and damaging fumes.

PART 2 PRODUCTS

2.01 LOBBY ACOUSTICAL WALL AND CEILING ABSORBING PANELS

- A. Absorber wall and ceiling panel composed of a v-line 1" thick, tectum panels direct attached to surface. Factory finish with chamfered edges. All exposed surfaces to be field painted. Color selected by Architect.
- B. Panels for continuous installation without a seam being visible. The "V" groove is 1/4" deep to match the beveled edges. This design divides the 2' wide panels into three 7 7/8" segments.
- C. Manufacturer: As manufactured by Tectum Inc. (614-345-9691) or approved equal.

PART 3 EXECUTION

3.01 INSTALLATION

- A. Install Tectum acoustic wall and ceiling absorber panels as shown on Drawings with counter sunk masonry screws.
- B. Prepare and paint as per Section 09 90 00 Painting and Coatings.

END OF SECTION

ACOUSTICAL WALL & CEILING TREATMENT

09 71 00 - 2

SECTION 09 90 00 PAINTING AND COATING

PART 1 GENERAL

1.01 REFERENCES

- A. General Conditions and Special Conditions of the Contract and Division 1 of the Specifications are a part of this Section as if stated in full herein.

1.02 SUMMARY

- A. Paint and finish schedules indicate the minimum coatings that can be anticipated to produce the desired results. Before submitting bid, Contractor and material suppliers examine such schedules and these specifications and should number or type of coatings be insufficient or inappropriate to achieve proper results notify Architect and receive his instructions; otherwise, should coatings specified not produce the desired coverage or finish results, Architect may require additional or other type coating and such shall not constitute a basis of claim for "Extra Work".
- B. Notwithstanding any omissions or discrepancies in paint and finish schedules, every item logically requiring paint or finish shall be properly painted or finished. Consult Architect for proper finish if not specified.

1.03 SUBMITTALS

- A. Contractor shall submit full range of color chips for Architect's color selection. It is anticipated that a limited palette of colors will be selected, however, no color or variety of colors selected will constitute claim for extra charge by Contractor.

PART 2 PRODUCTS

2.01 MANUFACTURERS

- A. Furnish first-quality paints as manufactured by Pittsburg Paints, Sherwin Williams, Glidden, Pratt and Lambert or Benjamin-Moore.
- B. Log Construction: Furnish Sikkens wood finishes as scheduled.

2.02 MATERIAL

- A. Except as noted, schedules herein indicate selections of materials from Pittsburg Paints to be used as a guide for establishing type of quality and finish desired.
- B. Log Construction: Schedules herein indicate selections of materials from Sikkens Wood finishes as a guide for establishing type and quality of finish desired.
- C. Requests for substitutions will be considered in accordance with provisions of Section 00 20 00.

PART 3 EXECUTION

3.01 PREPARATION

- A. Clean surfaces of rust, grease, oils, and other foreign matter that would adversely affect finished appearance or protective properties of the paint.
- B. Fill holes and cracks in surfaces with spackle. Apply no paint until spackle is thoroughly dry.
- C. Touch up knots and sappy spots on wood materials to be painted with pure shellac before priming.
- D. Sand and otherwise clean and smooth wood surfaces to be finished. Do not use steel wool on surfaces scheduled to receive water-based finishes.
- E. Before painting or finishing adjacent areas, remove and protect hardware, accessories, plates, light fixtures and similar items. On completion of area, replace such items.
- F. Log Construction: The best method to prepare log surfaces is to sand with 80-120 grit sandpaper. However, the following preparation may be used as an alternate to sanding: Spray the surface with clean water, wetting the wood. Clean the surface with a solution of four (4) ounces of 100% powdered Tri-Sodium Phosphate (TSP) or phosphate-free substitute plus one (1) quart of liquid bleach in three (3) quarts of water. Apply this solution generously to the wood with a garden pump sprayer. Let the solution sit on the wood for 15 – 20 minutes. During this period, scrub the surface with a hard bristle brush to help remove mill glaze and/or weathering. Do not let the solution dry on the wood. Keep it wet. Power wash the cleaning solution from the wood with clean water. To prevent damaging the wood, do not exceed 500 PSI. The nozzle must be a maximum of one (1) foot from the surface for full effectiveness. Let the surface dry for three (3) days before application (i.e. the moisture content is below 18%). Weathered gray wood, or wood affected with blue fungi or rust from nails may be treated, after cleaning with the TSP solution, by applying a solution of four (4) ounces of oxalic acid crystals in a gallon of warm water. This solution shall be allowed to sit on the affected area for 15 – 20 minutes before the final rinse with a power washer. Do not let the solution dry on the surface. After treatment, allow surface to dry for three (3) full days. Fill all joints, cracks, and nail holes with a high quality caulk/filler and let cure prior to applying the coating system. Refer to caulk/filler manufacturer for proper application.

3.02 APPLICATION

- A. Spread materials evenly and smoothly, without runs or sags. Apply interior latex paints with roller and/or brush. Spray apply paints to metal doors and metal frames. (Exterior Cedar siding and log construction components and accents shall be wet on wet applications.)
- B. Prime exterior surface materials immediately after their installation, or whenever possible, before installation. (Exterior cedar siding shall be back primed.)
- C. Color undercoats to approximate value of finish coat.
- D. Sand woodwork and metal trim between coats with fine sand paper to produce an even, smooth finish.

- E. Cover surfaces to be stained with uniform stain coat; wipe off as required.
- F. Apply materials per manufacturer's directions and obtain good coverage and perfect finish for type of paint or finish.
- G. "Touch up" paint and finish surfaces after all trades and contractors have completed their work.
- H. After wood doors are fitted, remove and give top and bottom edges one coat of pure shellac for interior doors, and one coat of same followed by one coat of spar varnish for exterior doors. Do not allow edge coating to lap onto face surfaces where natural finishes are required.
- I. Log Construction: Prior to application perform a two (2) coat color and sheen test on a sample of the wood for approval by the Architect. Intermix batches to ensure color consistency. After preparation apply two (2) coats of scheduled finish assuring thorough dry time (minimum 24 hours) between coats. During application, saturate all end grains, nail holes, cavities, and cracks in the wood. Brush on a liberal coat and maintain a wet edge to prevent lap marks. Brush in the direction of the wood grain starting at one end of the board or log and continuing to the other end of the board or log. The first coat should be applied from the bottom up to avoid drips which may streak on the surface below. Scheduled finish requires UV light to cure properly. The absence of UV light will significantly slow the drying process.

3.03 PAINTING SCHEDULE (EXTERIOR)

- A. Ferrous Metal - Steel Doors and Frames, Bollards, Structural Steel, Plates (alkyd):
 - 1. One (1) coat PPG Speedhide Int/Ext Rust Inhibitive Steel Primer 6-208 Series (6-212), DFT – 2.3 mil.s
 - 2. Two (2) coats PPG Speedhide Gloss Oil Int/Ext Gloss 6-282 Series (6-284), DFT – 2.0 mils/coat OR PPG Manor Hall Exterior Premium Eggshell Acrylic Latex 79-45 Series, DFT – 1.5 mils per coat
- B. Cedar Siding, Composites, Wood Shake Panels:
 - 1. PPG Olympiac Water Repellent Semi-Transparent Oil Stain 51100 Series (51102).
- C. Log Construction: (**Moisture Content must be 18% or less before application**)
 - 1. Two (2) coats: Sikksens Wood Finishes, Cetol log and siding finish.

3.04 PAINTING SCHEDULE (INTERIOR)

- A. Concrete Masonry Units (100% acrylic) (egg shell):
 - 1. One (1) coat PPG Aquapon Polyamide Epoxy Block Filler 97-685/686 at 12.0-18.0 mils DFT.
 - 2. Two (2) coats PPG Aquapon WB Water Base Epoxy 98-1 Series (98-51) at 2.0-3.0 mils DFT.
- B. Gypsum Wall Board (acrylic latex) (egg shell)
 - 1. One (1) coat PPG Speedhide Interior Latex Primer Sealer 6-2.
 - 2. Two (2) coats PPG Pure Performance Interior Semi-Gloss Latex 9-500 Series, DFT – 1.5-1.7 mils/coat.

- C. Metal Doors/Frames and Miscellaneous Metals (acrylic) (semi-gloss):
 - 1. One (1) coat coat PPG Speedhide Int/Ext Rust Inhibitive Steel Primer 6-208 Series (6-212), DFT – 2.3 mils.
 - 2. Two (2) coats PPG Speedhide Interior Semi-Gloss Alkyd Enamel 6-1110 Series, DFT – 1.7 mils/coat

- D. All wood trim (polyurethane):
 - 1. One (1) coat Natural Paste Wood Filler (tinted)
 - 2. One (1) coat PPG Olympic Premium Interior Fast Dry Wood Stain Oil Based 41570 Series
 - 3. Two (2) coats PPG Olympic Premium Interior Oil Based Polyurethane Clear 43884, 43886, 1.0 mils/coat.

- E. Log Construction: **(Moisture Content must be 18% or less before application)**
 - 1. Two (2) coats: Sikkens Wood Finishes, Cetol log and siding finish.
 - 2. All interior log construction components shall be finished in outdoor atmosphere prior to erection and application.

END OF SECTION

SECTION 10522 - FIRE EXTINGUISHERS, CABINETS, AND ACCESSORIES

PART 1 - GENERAL

1.1 SECTION REQUIREMENTS

- A. Submit Product Data.
- B. Provide fire extinguishers approved and listed with UL or FM, and bearing UL or FM markings, for the type, rating, and classification of extinguisher.

PART 2 - PRODUCTS

2.1 FIRE EXTINGUISHERS AND CABINETS

- A. Fire Extinguishers: Multipurpose dry-chemical type, with UL rating of for project.
- B. Cabinets: Semi-recessed, trimless, enameled steel with baked enamel finish, solid panel door.

PART 3 - EXECUTION

3.1 INSTALLATION

- A. Provide a cabinet for each fire extinguisher unless a mounting bracket is indicated as shown on drawings.
- B. Install cabinets and brackets at heights indicated or, if not indicated, at heights to comply with applicable regulations of authorities having jurisdiction.
- C. Identify bracket-mounted extinguishers with "FIRE EXTINGUISHER" in red letter decals applied to wall surface. Letter size, style, and location as selected by Architect.

END OF SECTION 10522

SECTION 10801 - TOILET AND BATH ACCESSORIES

PART 1 - GENERAL

1.1 SECTION REQUIREMENTS

- A. Submit Product Data.

PART 2 - PRODUCTS

2.1 TOILET AND BATH ACCESSORIES

- A. Toilet and bath accessories as indicated in the schedule at the end of this Section.

1. Electric Hand Dryer
2. Double Roll Tissue Dispenser: Bobrick
3. Sanitary Napkin Dispenser: Stainless steel, 22 ga., seamless door, 18 ga., tumbler lockset, 15 napkin and 20 tampon capacity, labeled coin slots, coin operation set at owners request.
4. Recessed Sanitary Napkin Disposal Units: Stainless steel for 4" wall depth, self closing door, removable stainless steel receptacle.
5. Soap Dispenser: Surface mounted liquid soap dispenser 12 oz. Minimum capacity, stainless steel piston, springs and internal parts, polished chromium finish.
6. Mirrors: 1/4" glass ASTM C 1036, frameless
7. Grab Bars: Stainless steel type, 18 ga., 1 1/2" outside diameter, concealed mounting.
8. Provide universal keys for access to toilet accessory units requiring internal access for servicing, resupply, etc. Provide a minimum of 6 keys to owner.
9. Stainless Steel: AISI Type 302 or 304, No. 4 polished finish
10. Chromium plated Brass or Steel: ASTM B 456, Type SC 2

PART 3 - EXECUTION

3.1 INSTALLATION

- A. Install toilet accessory units using fasteners appropriate to substrate. Install units level and plumb, firmly anchored in locations, and at heights indicated. Comply with provisions of ADAAG for installation of units required to be accessible to the disabled.**

END OF SECTION 10801

- Model 237 — Recessed
- Model 237-10 — Semi-Recessed (recesses 3½"; projects 4")
- Model 237-11 — Surface-Mounted (projects 7½")
- Standard Series — Satin Finish

Product Materials

CABINET: 22 gauge stainless steel with exposed surfaces in architectural satin finish. Welded construction with seam-less corners and burr-free edges.

FLANGE: 22 gauge stainless steel with exposed surfaces in architectural satin finish. One piece seamless construction, 1" wide with ¼" return.

DOOR: 18 gauge stainless steel. Warp resistant, with full length piano hinge and tumbler lock keyed like other Bradley units.

TOWEL DISPENSER: 22 gauge stainless steel. Rolled edge on dispenser opening.

WASTE RECEPTACLE: 22 gauge stainless steel. All welded construction. Secured to cabinet with tumbler lock keyed like other Bradley units.

LINER (optional): heavy duty stitched vinyl coated nylon. Part #P11-004.

CUP DISPENSER (optional): 22 gauge stainless steel.

HINGED COVER (optional): 22 gauge stainless steel with exposed surfaces in architectural satin finish. Heavy duty stainless steel piano hinge.

PUSH FLAP DOOR (optional): 22 gauge stainless steel with exposed surfaces in architectural satin finish. Heavy duty stainless steel piano hinge. Self-closing flap door is embossed "PUSH".

Capacity

Towel Dispenser — 1100 single fold, 800 multi fold or 600 C-fold paper towels;
Waste Container — 12 gal. (1.6 cu. ft.); Cup Dispenser (optional) — 100 - 3 oz. cups

Operation

Towel dispenser holds single-fold, multi-fold or C-fold towels with use of special adaptor. Receptacle removable for easy servicing by unlocking waste container.

Installation

Verify all rough-in dimensions prior to installation. Recessed unit requires rough wall opening 15¼" W x 54½" H x 7½" D (Semi-recessed unit only 3½" deep). Secure to framing with mounting screws (included) at holes provided. Shim at screw points as required. Surface-mounted units must have holes drilled by installer.

Guide Specification

Recessed combination towel dispenser and waste receptacle shall be fabricated of 22 gauge stainless steel with exposed surfaces in satin finish. Cabinet doors with full length piano hinge and secured by tumbler lock. Towel dispenser capacity 1100 single-fold, 800 multi-fold or 600 C-fold towels. Removable 12 gal. stainless steel waste receptacle. Reusable vinyl liner is optional.

Overall dimensions: 17½" W x 56" H x 8¾" D.

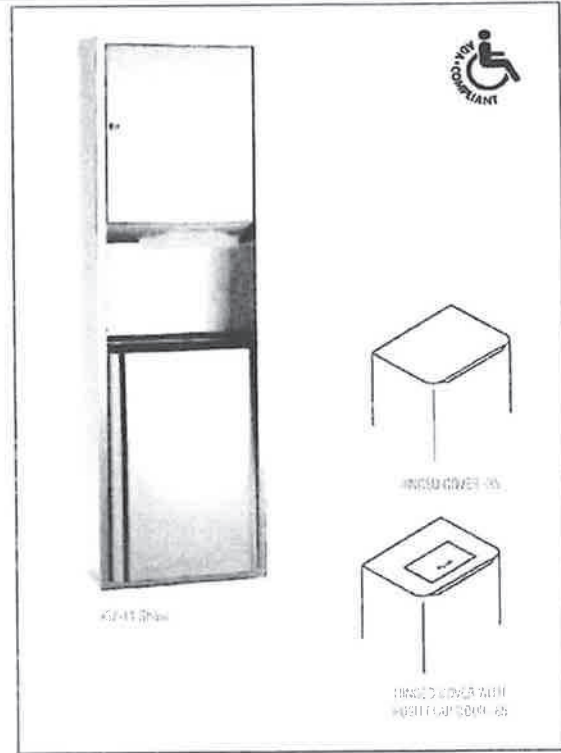

Optional Features

Feature	Suffix
<input type="checkbox"/> Hinged Cover	-35
<input type="checkbox"/> Large Capacity Waste Receptacle — 18 gal. (Not ADA Compliant)	-36
<input type="checkbox"/> Hinged Cover with Push Flap Door	-65

ADA Compliant

- Consult local and national accessibility codes for proper installation guidelines.
- Conformity and compliance to local and national codes is the responsibility of the installer.

Washroom Accessories
Document No. 8145

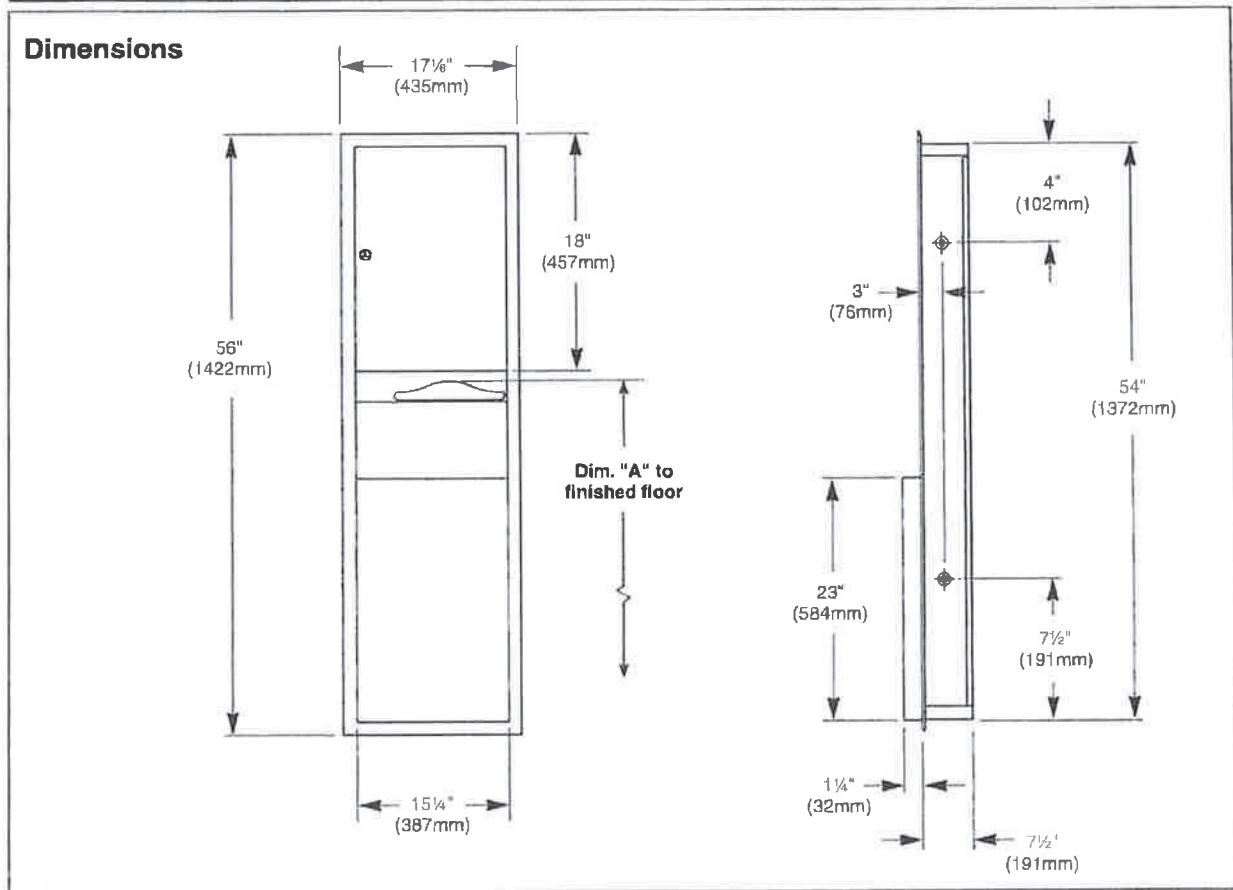

Dim. "A" Key Surface:	For Dim. "A"	Top of Rough Wall Opening	Bottom of Rough Wall Opening
Paper towel top of opening to finished floor	48" (1219mm)	66 3/4" (1695mm)	12 1/2" (311mm)
	45" (1143mm)	63 3/4" (1619mm)	9" (235mm)
	42" (1067mm)	60 3/4" (1543mm)	6 1/4" (159mm)
	40" (1016mm)	58 3/4" (1492mm)	4 1/4" (108mm)
Rough wall opening:			
Surface Mount:	No rough opening, see overall dimensions		
Recessed:	15 3/4" (401mm) Wide x 54 1/2" (1385mm) High x 7 1/2" (191mm) Deep		
Semi-Recessed:	15 3/4" (401mm) Wide x 54 1/2" (1385mm) High x 3 1/2" (89mm) Deep		

**Washroom Accessories
Document No. 8145**



2902-2800, 2902-2873, 2902-2874

Adjustable Motor, Adjustable Sensor-Operated Warm Air Hand Dryer

Recommended for very high traffic areas.

- Standard Model 2902-280000 (cast iron white porcelain) **Bradlex**
- Standard Model 2902-287300 (steel-white epoxy) **Bradlex**
- Standard Model 2902-287400 (stainless steel-satin finish) **Bradlex**

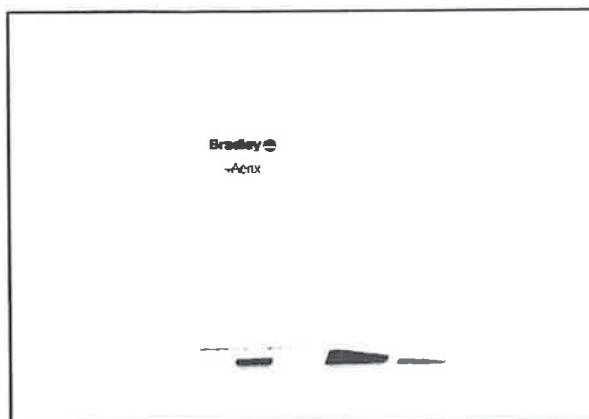

Product Materials

2902-2800 COVER: 3/16" (4.5 mm) thick one-piece cast iron; white porcelain enamel coating.

2902-2873 COVER: 1/16" (1.5mm) thick one-piece steel; white epoxy finish.

2902-2874 COVER: 1/16" (1.5mm) thick one-piece stainless steel; satin finish.

Cover fixed to the base plate with two vandal-proof lock screws and lock with special key wrench.

ADJUSTABLE MOTOR: universal-type with high-speed, universal brush, fully adjustable (3,800-8,200 RPM) potentiometer, Class A, Aluminium centrifugal double asymmetrical inlet fan wheel; aluminum scroll fan and safety thermal cut-off.

HEATING ELEMENT: waved wire NiCr heating element mounted on a mica frame that incorporates a self-resetting thermal cut-off at 302°F.

ADJUSTABLE SENSOR OPERATION: electronic infrared detection sensor with fully adjustable (2"-8") potentiometer. Includes polycarbonate viewing windows. Automatic shut-off after 60 seconds.

BASE PLATE: 1/8" (3 mm) thick aluminum, with four Ø 3/16" (8 mm) holes for wall mounting. Includes silent blocking to dampen mechanical vibrations.

Installation

Verify all rough-in dimensions prior to installation. Hand dryers require a dedicated circuit and must be properly grounded. GFI Circuit protection is recommended. One side of dryer should be mounted to a stud.

Operation

Place hands 3"-6" below nozzle to activate air flow. Dryer will stop two seconds after hands are removed from air flow.

ADA Compliant

- Consult local and national accessibility codes for proper installation guidelines.
- Conformity and compliance to local and national codes is the responsibility of the installer.

**Washroom Accessories
Document No. 8256**

Guide Specification

Surface-mounted ADA-compliant hand dryer shall have a thick cast iron cover with white porcelain enamel coating (2902-2800) or steel cover with white epoxy coating (2902-2873) or stainless steel cover with satin finish (2902-2874). Hand dryer shall include aluminium base plate, fully adjustable (2" - 8") infrared sensor potentiometer and fully adjustable (3800 - 8200 RPM) universal-type motor potentiometer with resilient mounts and sealed, lubricated ball bearings. Dryer shall operate at 64-70 dB while delivering 43-70 CFM of air at 106°F-111°F (41°C-44°C) and 4,920-9,840 LFM velocity during user-controlled drying cycle. Dryer shall have a total power of 800-1,150 W (1.07-1.54 Hp) with a consumption of 9.5-4.8 A.

Overall dimensions: 10½"H x 11½"W x 4"D (267mm x 292mm x 102mm).

Weight: 7.9 lb (3.58 kg)

Product Specifications

Voltage:	100-120 V, 208 V, 220-240 V	Consumption:	9.5-4.8 A
Motor:	1/2 HP (250 W)	RPM:	3,800-8,200
Nominal power:	1,150 W (1.54 Hp)	Heating element:	900 W (1.20 Hp)
Effective airflow:	36-58 CFM	Nominal airflow:	43-70 CFM
Noise level at 79":	64-70 dB	Airspeed:	4,920-9,840 LFM
Frequency:	50/60 Hz	Insulation:	Grounding required
Temperature (at 4" distance / 70°F):	106°F-111°F (41°C-44°C)	Certificates:	UL 499 / CSA C22.2 / VDE GS / VDE EMC
Drying time:	12-15 seconds	Mounting:	Surface, ADA-compliant
Protection level:	IP23 Splash Protection		

Orders composed of products indicated as **Bradlex** will be available to ship in three days after receipt of order at the factory. There is no pricing penalty for this service from Bradley.

Page 1 of 2

This information is subject to change without notice.

1/6/2014

© 2014 Bradley
P.O. Box 309, Menomonee Falls, WI 53052-0309
Phone: 800.BRADLEY (800.272.3539) Fax: 262.253.4161
bradleycorp.com



2902-2800, 2902-2873, 2902-2874

Adjustable Motor, Adjustable Sensor-Operated Warm Air Hand Dryer

Dimensions

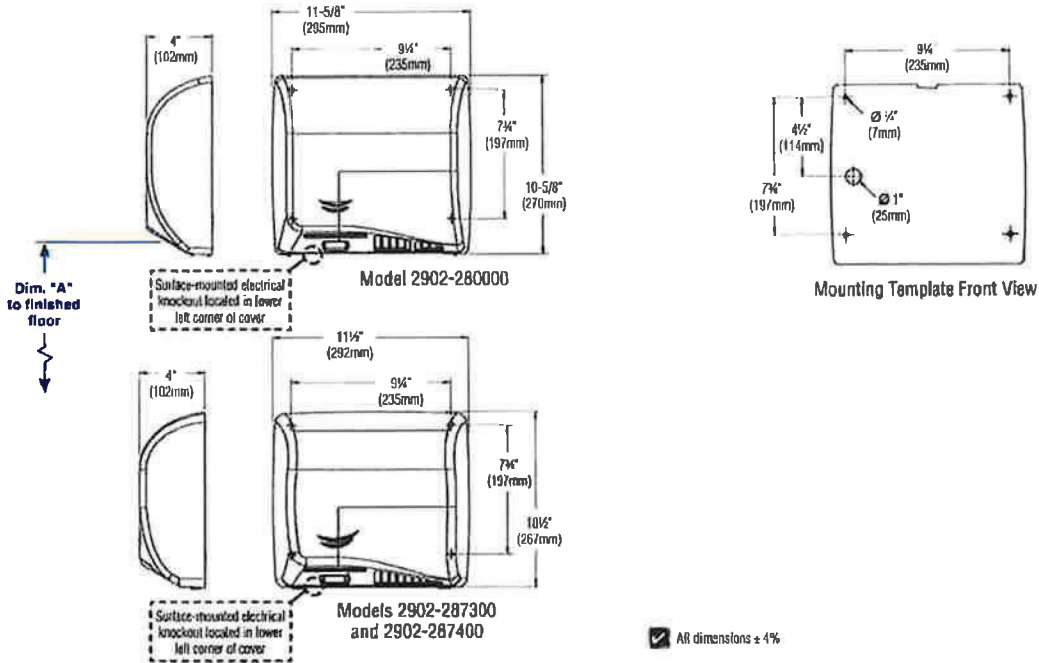

Dim. "A" Key Surface:	For Dim. "A"	Top of Unit	Bottom of Unit
Sensor top to finished floor	48" (1219mm)	57 3/4" (1467mm)	47 1/8" (1197mm)
	45" (1143mm)	54 3/4" (1391mm)	44 1/8" (1121mm)
	42" (1067mm)	51 3/4" (1314mm)	41 1/8" (1045mm)
	40" (1016mm)	49 3/4" (1264mm)	39 1/8" (994mm)
Rough wall opening:			
Surface Mount:	No rough opening, see overall dimensions		

Washroom Accessories
Document No. 8256

Orders composed of products indicated as **Bradlex** will be available to ship in three days after receipt of order at the factory. There is no pricing penalty for this service from Bradley.

Page 2 of 2

This information is subject to change without notice.

1/6/2014

© 2014 Bradley
P.O. Box 309, Menomonie Falls, WI 53052-0309
Phone: 800.BRADLEY (800.272.3539) Fax: 262.253.4161
bradleycorp.com

- Model 4737 — Recessed**
- Model 4737-10 — Semi-Recessed**
(recesses 2 $\frac{1}{8}$ " ; projects 2")
- Model 4737-11 — Surface-Mounted**
(projects 4 $\frac{1}{8}$ ")

- Contemporary Series — Satin Finish
- Concealed Hinge and Lock

Product Materials

CABINET: 22 gauge stainless steel with exposed surfaces in architectural satin finish. Welded construction with burr-free edges.

DOOR: 18 gauge stainless steel. $\frac{1}{2}$ " return for maximum rigidity. Concealed full length stainless steel piano hinge and tumbler lock.

PUSH FLAP DOOR: 22 gauge stainless steel with exposed surfaces in architectural satin finish. Heavy-duty stainless steel piano hinge.

WASTE RECEPTACLE INSERT fabricated of leakproof molded plastic.

Capacity

1.5 gal (0.2 cu. ft.)

Operation

Waste container removable by unlocking cabinet door. Furnished with waxed paper liner. Box of 500 waxed paper liners are available by ordering part number P11-022.

Installation

Verify all rough-in dimensions prior to installation. Recessed unit requires rough wall opening 11 $\frac{1}{8}$ "W x 15 $\frac{3}{4}$ "H x 4"D (Semi-recessed unit only 2 $\frac{1}{2}$ " deep). Secure to framing with mounting screws (included) at holes provided. Shim at screw points as required.

Guide Specification

Recessed napkin disposal shall be fabricated of stainless steel with exposed surfaces in satin finish. Door with full-length concealed piano hinge and lock. Self-closing push flap door secured by piano hinge. Removable molded plastic receptacle.

Overall dimensions: 13"W x 17 $\frac{3}{8}$ "H x 4 $\frac{1}{8}$ "D.

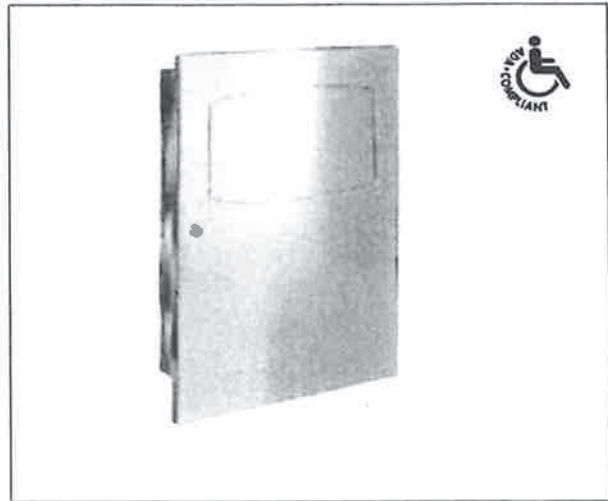

ADA Compliant

- Consult local and national accessibility codes for proper installation guidelines.
- Conformity and compliance to local and national codes is the responsibility of the installer.

Washroom Accessories
Document No. 8405

Dimensions

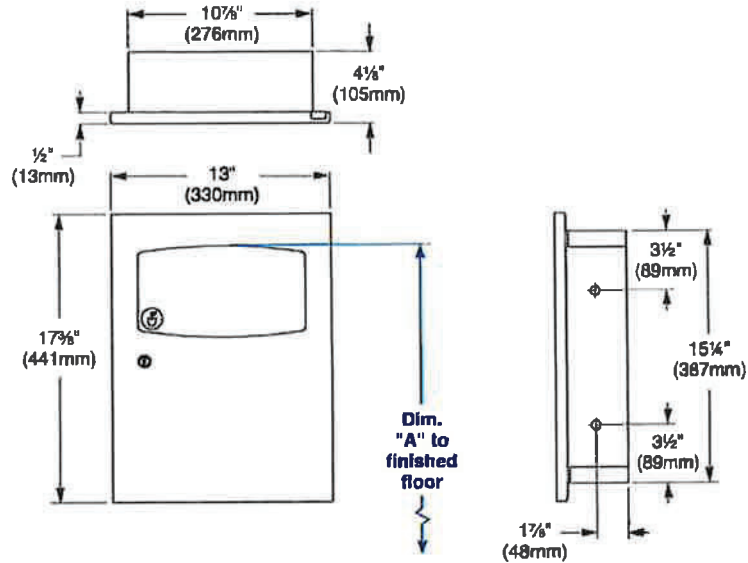

Dim. "A" Key Surface:	For Dim. "A"	Top of Rough Wall Opening	Bottom of Rough Wall Opening
Top of Door (5 1/2" Door Opening) to Finished Floor	48" (1219mm)	49" (1245mm)	33 1/4" (845mm)
	45" (1143mm)	46" (1168mm)	30 1/4" (768mm)
	42" (1067mm)	43" (1092mm)	27 1/4" (692mm)
	36" (914mm)	37" (940mm)	21 1/4" (540mm)
	33" (838mm)	34" (864mm)	18 1/4" (464mm)
Rough wall opening:			
Surface Mount:	No rough opening, see overall dimensions		
Recessed:	11 3/8" (289mm) Wide x 15 3/4" (400mm) High x 4" (102mm) Deep		
Semi-Recessed:	11 3/8" (289mm) Wide x 15 3/4" (400mm) High x 2" (51mm) Deep		

Washroom Accessories
Document No. 6405

Model 5402 — **BradEx**[®]

- Dual Roll

Product Materials

CABINET: 22 gauge stainless steel with exposed surfaces in architectural satin finish. Welded construction with burr-free edges.

SERVICE DOOR: 22 gauge stainless steel with exposed surfaces in architectural satin finish and lumber lock keyed like other Bradley units. Hinged at bottom.

SPINDLES: molded polyethylene.

Capacity

Two standard core toilet tissue rolls through 5" in diameter.

Operation

Cabinet holds two rolls of 4½" x 5" standard core toilet tissue, one above the other. When first roll is used up, fresh roll automatically drops down for use. Unique retaining mechanism prevents use of spare roll until first roll is completely used. Spindles non-removable by user. Hinged door permits access to storage compartment for servicing of unit.

Installation

Verify all rough-in dimensions prior to installation. Secure to wall with mounting screws (not included) at holes provided. Mounting Kit #899-027 available from Bradley. Visit www.bradleycorp.com for more information. Provide in-wall backing at mounting screw locations.

Guide Specification

Surface-mounted dual roll toilet tissue dispenser shall be heavy gauge satin finish stainless steel and hold two standard core toilet tissue rolls.

Overall dimensions: 5½"W x 10"H x 5½"D.

ADA Compliant

- Consult local and national accessibility codes for proper installation guidelines.
- Conformity and compliance to local and national codes is the responsibility of the installer.

Washroom Accessories
Document No. 8545

Orders composed of products indicated as **BradEx**[®] will be available to ship in three days after receipt of order at the factory. There is no pricing penalty for this service from Bradley. This information is subject to change without notice.

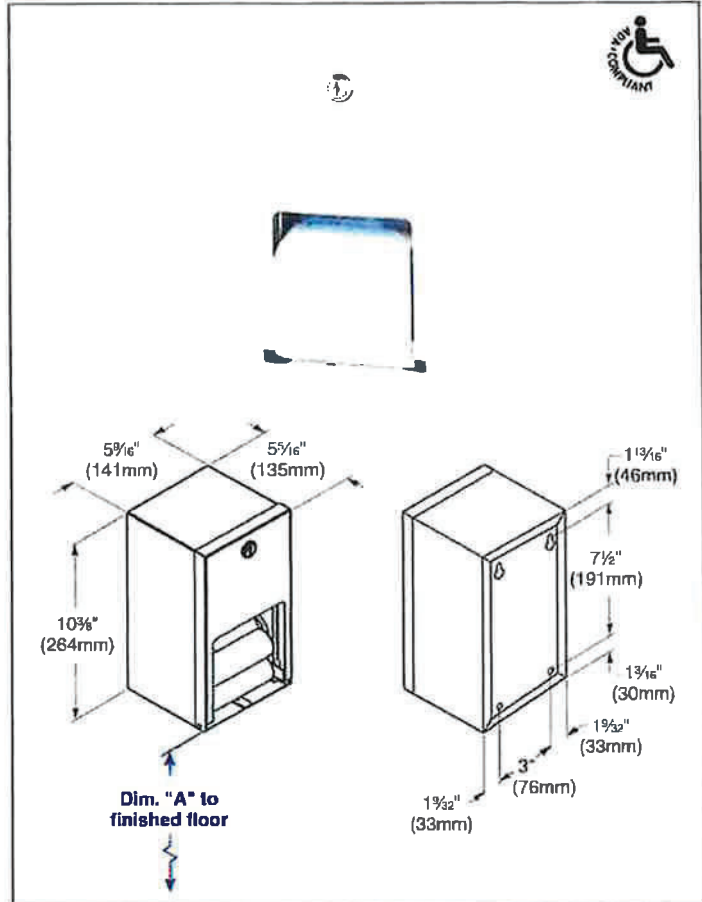

Dim. "A" Key Surface:	For Dim. "A"	Top of Unit	Bottom of Unit
Bottom of toilet paper opening to finished floor	20" (508mm)	30¼" (768mm)	19¾" (505mm)
	19" (483mm)	29¼" (743mm)	18¾" (479mm)
	18" (457mm)	28¼" (718mm)	17¾" (454mm)
	17" (432mm)	27¼" (692mm)	16¾" (429mm)
	16" (406mm)	26¼" (667mm)	15¾" (403mm)
	15" (381mm)	25¼" (641mm)	14¾" (378mm)
Rough wall opening:			
Surface Mount:		No rough opening, see overall dimensions	

- Tank-Type Vertical Valve
- Surface-Mounted
- ADA Compliant

Product Materials

BODY: 20 gauge stainless steel with exposed surfaces in architectural satin finish.

BACK: 20 gauge stainless steel; welded to the body.

WALL PLATE: stainless steel.

SOAP VALVE: chrome-plated brass housing with ABS plastic and stainless steel mechanism. Requires less than 5 lbs. force to dispense soap.

Capacity

40-oz. liquid soap.

Operation

Push-up valve dispenses measured amount of vegetable or coconut oil liquid soaps, synthetic detergents, and antiseptic solutions. Sight gauge indicates refill time. Locked filler top opens with special key provided. Requires less than 5 lbs. of force to dispense soap.

- Bradley liquid soap valves operate best with any **vegetable** oil or **coconut** oil hand soap having a 10–15% soap concentration.

Installation

Verify all rough-in dimensions prior to installation. Secure separate mounting bracket to wall. Slide dispenser into place and secure locking screw through filler hole.

Guide Specification

Surface-mounted liquid soap dispenser shall be fabricated of 20 gauge satin finish stainless steel. Dispenser shall have completely concealed mounting, vandal-resistant filler hole cover and sight gauge. Push-up corrosion-resistant liquid soap valve. Requires less than 5 lbs. of force to dispense soap.

Overall dimensions: 4³/₁₆"W x 8³/₁₆"H x 2⁷/₁₆"D.

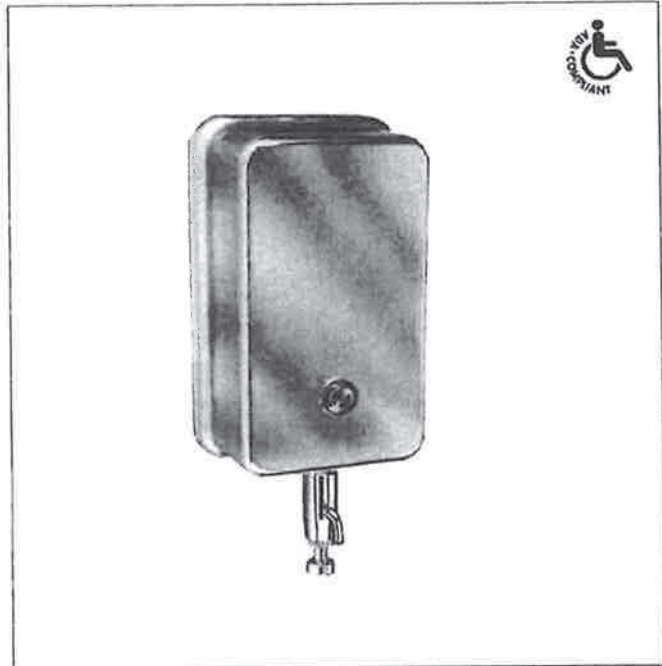

ADA Compliant

- Consult local and national accessibility codes for proper installation guidelines.
- Conformity and compliance to local and national codes is the responsibility of the installer.

Washroom Accessories
Document No. 8685

Dimensions

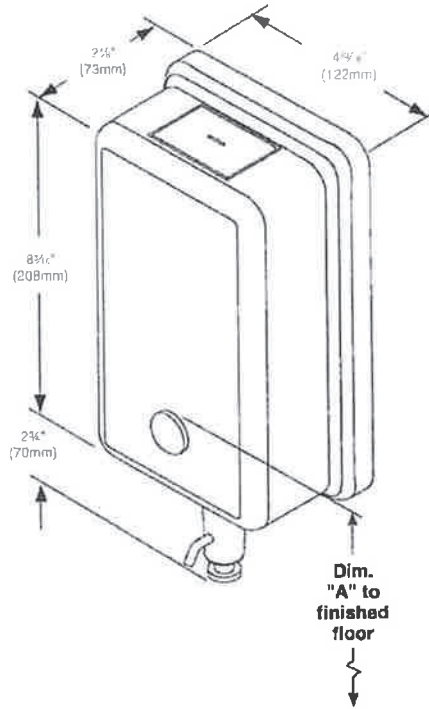

Dim. "A" Key Surface:	For Dim. "A"	Top of Unit	Bottom of Unit
Push button top to finished floor	40" (1016mm)	50 1/4" (1276mm)	39 3/16" (999mm)
	38" (965mm)	48 1/4" (1226mm)	37 1/16" (948mm)
	36" (914mm)	46 1/4" (1175mm)	35 3/16" (897mm)
	34" (864mm)	44 1/4" (1124mm)	33 3/16" (846mm)
Rough wall opening:			
Surface-Mount:	No rough opening, see overall dimensions		

Washroom Accessories
Document No. 8685

Unbreakable stainless steel mirror with No. 8 architectural bright finish:

Model 748-XXXX (Specify width and height)

Product Materials

MIRROR: 20 gauge stainless steel, polished to No. 8 architectural bright finish. Stretcher leveled for uniformity. Very bright – excellent reflectivity, very slight polish grain. ¼" return conceals backing.

BACKING: tempered Masonite bonded to mirror with adhesive.

Stainless steel mirrors will differ in optic quality from glass mirrors.

Installation

Verify all rough-in dimensions prior to installation. Secure to wall with tamper-resistant mounting screws (included) at holes provided. Provide in-wall backing at mounting screw locations.

Guide Specification

Mirror shall be fabricated of 20 gauge stainless steel with No. 8 architectural finish. Unit shall have ¼" return to conceal ¼" tempered Masonite backing bonded to mirror with adhesive.

Stainless Steel Mirror shall be Bradley Model 748-_____ " W x _____ " H (specify width and height).

Model 748 series stainless steel mirrors can be fabricated to a maximum size of 47½"W x 72"H.

In larger sizes, these units are subject to distortion and/or "oil canning" for which Bradley Corporation cannot accept responsibility.

ADA Compliant

- Consult local and national accessibility codes for proper installation guidelines.
- Conformity and compliance to local and national codes is the responsibility of the installer.

Dim. "A" Key Surface:	For Dim. "A"	Bottom of Unit
Mirror's bottom edge of the reflecting surface to finished floor	40" (1016mm)	40" (1016mm)
	37" (940mm)	37" (940mm)
	34" (864mm)	34" (864mm)
Rough wall opening:		
Surface Mount:	No rough wall opening, see overall dimensions	

Washroom Accessories
Document No. 8740

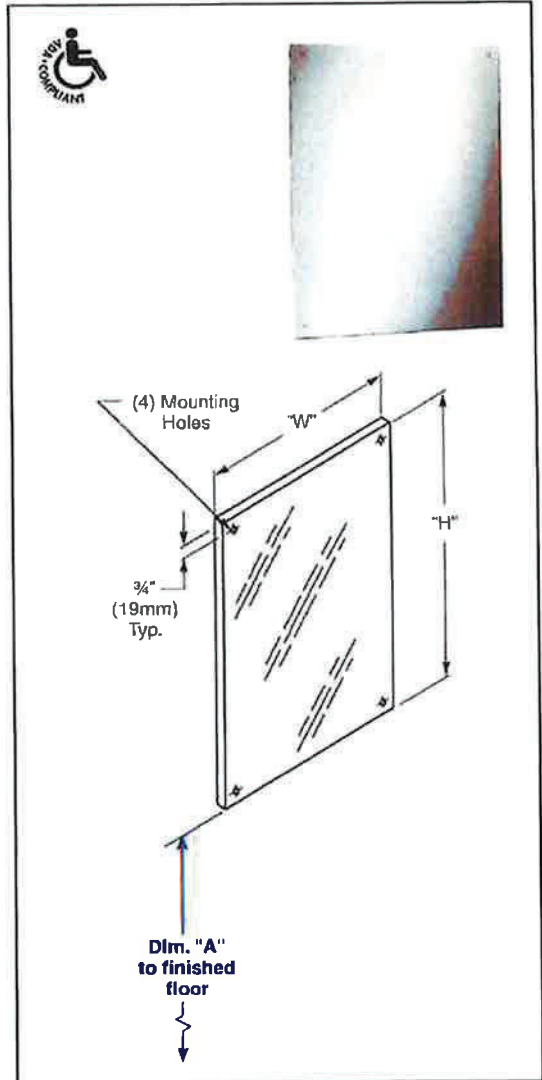

1½" O.D. heavy duty stainless steel grab bar with concealed mounting:

Product Materials

FLANGES: 3/4" dia. 13 gauge stainless steel.

ESCUTCHEONS: 22 gauge stainless steel. One-piece drawn construction with exposed surfaces in architectural satin finish. Snap over flanges to conceal mounting screws.

TUBING: 1½" O.D., 18 gauge stainless steel, seamless construction with exposed surfaces in architectural satin finish. Bent ends of tubing pass thru the flanges and are welded for maximum strength. Intermediate supports are contour cut and joined by welding to form an integral part of the grab bar. All exposed welds ground and polished to blend. Mandrel bending process maintains uniform bar diameter. Return provides 1½" standard safety clearance between wall and bar.

Strength

When properly mounted, all Bradley heavy duty grab bar systems meet or exceed the requirements of ANSI Standard A117.1, the ADA and ABA Accessibility Guidelines for Buildings and Facilities (ADAAG), and the Uniform Federal Accessibility Standard (UFAS). Select dimensions of configurations (-001, -054, -055, -059) are APMO certified to support up to 1000 pounds. (Please see Bradley's web site for more information on all grab bar configurations.)

Installation

Verify all rough-in dimensions prior to installation. Secure to wall where adequate in-wall backing exists. Use bar as template to locate mounting holes. Drill holes and set anchors as appropriate. Mount grab bar and secure mounting screws (not included). Snap escutcheons into place. For information on Bradley grab bar mounting kits, please visit bradleyccrp.com.

Optional Features

Features	Suffix
<input type="checkbox"/> Safety-grip finish	-2
<input type="checkbox"/> High-polish finish	-4
<input type="checkbox"/> Safety grip with high-polished finish	-7
<input type="checkbox"/> Antimicrobial finish: 18", 24", 36" & 42" only	-AM

Guide Specification

Grab bar shall be fabricated of satin finish stainless steel with concealed mounting flanges in sizes and configurations as indicated. Install with Bradley Mounting Kits as indicated.

ADA Compliant

- Consult local and national accessibility codes for proper installation guidelines.
- Conformity and compliance to local and national codes is the responsibility of the installer.

**Washroom Accessories
Document No. 8810**

This information is subject to change without notice

8/12/2013

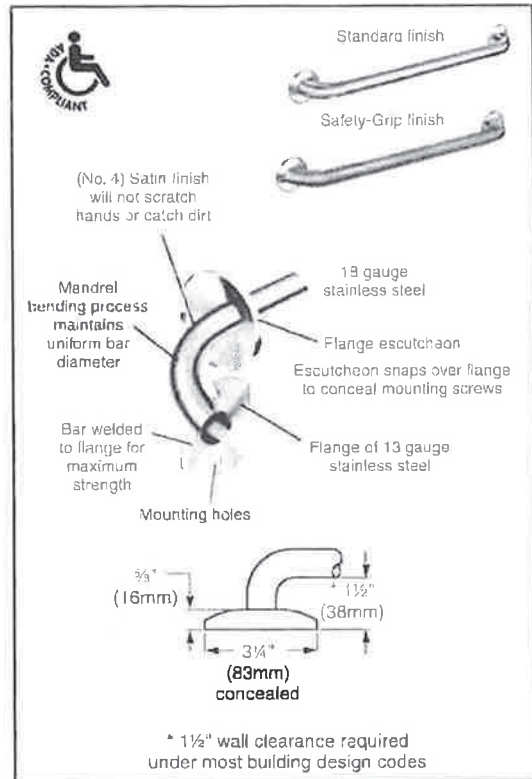

Bradex® Models

Configuration Number	Shipping Data		Configuration Number	Shipping Data	
	CU. FT.	WT. LBS.		CU. FT.	WT. LBS.
001-18"	0.14	2	001-42"	0.15	4
001-24"	0.14	3	001-48"-10"	3.14	24.67
001-30"	0.15	3	001-48"	0.25	4
001-36"	0.15	3	059**	2.85	7
001-36-10"	2.40	30.16			

NOTE: These units must ship via common carrier
 ** 059, 40" x 52" Standard Dimensions.
 • indicates available Safety Grip. **Bradex®**

Orders composed of products indicated as **Bradex®** will be available to ship in three days after receipt of order at the factory. There is no pricing penalty for this service from Bradley.

© 2013 Bradley
 P.O. Box 309, Menomonee Falls, WI 53052-0309
 Phone: 800.BRADLEY (800.272.3539) Fax: 262.253.4161
bradleycorp.com

- ☑ Model 962 – Recess-Mounted **Bradex**®
- ☑ Model 962-11 – Surface-Mounted **Bradex**®
- ☑ Meets relevant sections of the CPSIA to the extent possible.
- ☑ Meets or exceeds ASTM F2285 Safety Specification for Commercial Changing Stations.

Product Materials

BODY: bacterial-resistant polyethylene with brushed 20 gauge stainless steel exterior. Rated to support static load of 250 lbs, tested to 390 lbs. Pneumatic gas shock mechanism to ensure smooth, safe open and close motions.

MOLDED DUAL LINER DISPENSER: holds approx. 50 per dispenser (liners sold separately).

SAFETY BELT: with cam-buckle, adjustable with one hand.

⚠ WARNING: Be sure to use reinforced backing behind wall where mounting screws or anchoring devices are installed to ensure adequate support for the baby changing station. All anchoring devices (supplied by installer) must be appropriate for specific wall construction. Severe personal injury and/or property damage may result from improper mounting.

♿ ADA Compliant

- ☑ Consult local and national accessibility codes for proper installation guidelines.
- ☑ Conformity and compliance to local and national codes is the responsibility of the installer.

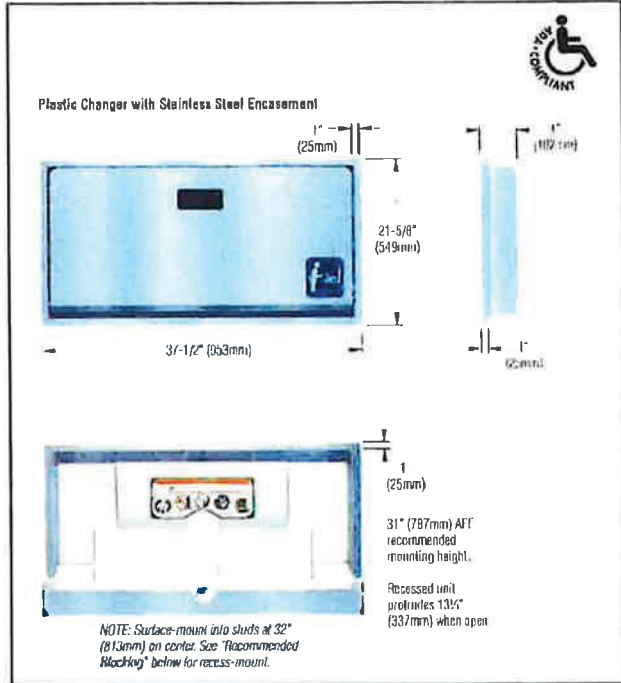

Service Parts Available

Part Number	Description
P11-021	Liners (100% bio-degradable), Case of 500

Washroom Accessories
Document No. 9033

Orders composed of products indicated as **Bradex**® will be available to ship in three days after receipt of order at the factory. There is no pricing penalty for this service from Bradley. This information is subject to change without notice.

4-25-2011

© 2011 Bradley Corporation
P.O. Box 309, Menomonee Falls, WI 53052-0309
Phone: 800.BRADLEY (800.272.3539) Fax: 262.253.4161
bradleycorp.com

Model 5A10-11—Surface-Mounted **Bradex®**

- Diplomat Series
- Dual Roll

Product Materials

CABINET: 0.030-inch/22ga.-(0.76 mm) stainless steel with exposed surfaces in architectural satin finish. Welded construction with seamless corners and burr-free edges.

SERVICE DOOR: 0.030-inch/22ga.-(0.76 mm) stainless steel with tumbler lock keyed like other Bradley units. Hinged at bottom.

SPINDLES: molded polyethylene.

Capacity

Single-roll dispenser with roll-in-reserve.

Operation

Cabinet holds two rolls up to 4-1/2"W x 5-1/4" diameter standard core toilet tissue, one above the other. When first roll is used-up, fresh roll automatically drops down for use. Unique retaining mechanism prevents use of spare roll until first roll is completely used. Spindles non-removable by user. Hinged door permits access to storage compartment for servicing of unit.

Installation

Surface mounted units must have holes drilled by installer. Secure unit to wall or partition with mounting screws (not included). Snip at screw points as required.

Guide Specification

Surface-mounted toilet tissue dispenser, with face formed with contemporary contours, radii, and finish matching related accessories in manufacturer's designer series. Single roll up to 5-1/4" diameter in standard roll dispenser with drop-down roll-in-reserve; rolls mounted on non-removable molded polyethylene spindles. Equipped with bottom-hinged service door with keyed tumbler lock. Universal keying. Formed from stainless steel sheet with satin finish on exposed surfaces. Fully welded, with seamless corners and burr-free edges: cabinet and door 0.030-inch / 22-ga. thick.

Overall dimensions: 5⁵/₈"W x 10³/₈"H x 6³/₈"D.

MasterFormat Title: Commercial Toilet Accessories

MasterFormat Number: 10 28 13.13

OmniClass Title: Toilet and Bath Specialties

OmniClass Code: 23.31.25.00

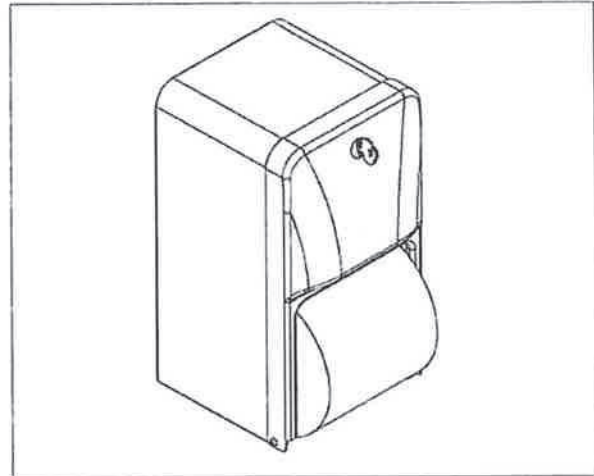

For information on Warranties, Maintenance and BAA/ARRA Compliance, visit our web site at:
bradleycorp.com/products/accessories/.

Washroom Accessories
Document No. 9414

Page 1 of 2

Orders composed of products indicated as **Bradex®** will be available to ship in three days after receipt of order at the factory. There is no pricing penalty for this service from Bradley. This information is subject to change without notice. 8-5-2011

© 2011 Bradley Corporation
P.O. Box 309, Menomonee Falls, WI 53052-3309
Phone: 800.BRADLEY (800.272.3539) Fax: 262.253.4161
bradleycorp.com

Dimensions

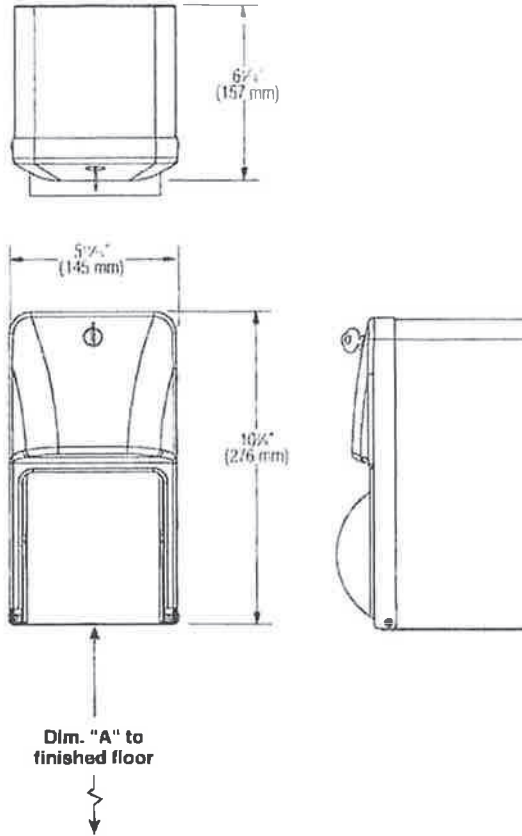

Dim. "A" Key Surface:	For Dim. "A"	Locate Top of Unit	Locate Bottom of Unit
Bottom of toilet paper opening to finished floor	20" (508mm)	30 3/4" (781mm)	19 7/8" (505mm)
	19" (483mm)	29 3/4" (756mm)	18 7/8" (479mm)
	18" (457mm)	28 3/4" (730mm)	17 7/8" (454mm)
	17" (432mm)	27 3/4" (705mm)	16 7/8" (429mm)
	16" (406mm)	26 3/4" (679mm)	15 7/8" (403mm)
	15" (381mm)	25 3/4" (654mm)	14 7/8" (378mm)

Washroom Accessories
Document No. 9414

Water Closet 3043.001.020 ADA

American Standard

Style That Works Better

 BARRIER FREE

**MADERA™ FloWise® 16-1/2" HEIGHT
ELONGATED FLUSHOMETER TOILET**
VITREOUS CHINA LESS EVERCLEAN®

**MADERA™ FloWise® 16-1/2" HEIGHT ELONGATED
LESS EVERCLEAN®**

- Floor mount flushometer valve toilet
- Vitreous china
- High Efficiency, Low Consumption. Operates in the range of 1.1 gpf to 1.6 gpf (4.2 Lpf to 6.0 Lpf)
- Meets definition of HET (High Efficiency Toilet) when used with a high efficiency flush valve (1.28 gpf or 1.6 / 1.1 gpf dual flush)
- Fully glazed 2-1/8" trapway
- Elongated bowl
- 10" or 12" roughing-in
- 16-1/2" rim height for accessible application
- Condensation channel
- Powerful direct-fed siphon jet action
- 10" x 12" water surface area
- 1-1/2" inlet spud
- 2 bolt caps
- 100% factory flush tested

- 3043.001** Elongated bowl only, top spud
- 3248.001** Elongated bowl only, top spud with slotted rim for bedpan holding (White only)
- 3249.001** Elongated bowl only, back spud

Component Parts:

- 047007-0070A** Inlet Spud (furnished with bowl)
- 481310-100** Bolt caps with retainers (furnished with bowl)

Nominal Dimensions:

718 x 356 x 419mm
(28-1/4" x 14" x 16-1/2")

Fixture only, less seat and flush valve

Recommended working pressure—between
25 psi at valve when flushing and 80 psi static

Compliance Certifications -

Meets or Exceeds the Following Specifications:

- ASME A112.19.2-2008 / CSA B45.1-08 for Vitreous China Fixtures



SEE REVERSE FOR ROUGHING-IN DIMENSIONS

To Be Specified:

- Color: White Bone
- Seat:
 - American Standard #5901.100 Heavy duty open front less cover
 - American Standard #5905.100 Extra heavy duty open front less cover
- Flushometer Valve:
 - 1.6 gpf:
 - Sensor-Operated: American Standard Selectronic® DC Power #6065.161.002 (Top Spud)
 - Sensor-Operated: American Standard Selectronic® AC Power #6067.261.002 (Back Spud)
 - Manual: American Standard #6047.161.002 (Top Spud)
 - 1.28 gpf:
 - Sensor-Operated: American Standard Selectronic® DC Power #6065.121.002 (Top Spud)
 - Sensor-Operated: American Standard Selectronic® AC Power #6067.221.002 (Back Spud)
 - Manual: American Standard #6047.121.002 (Top Spud)
 - 1.6 / 1.1 gpf Dual Flush:
 - Sensor-Operated: American Standard Selectronic® DC Power #6065.761.002 (Top Spud)



MEETS THE AMERICANS WITH DISABILITIES ACT GUIDELINES
AND ANSI A117.1 REQUIREMENTS FOR ACCESSIBLE AND USABLE
BUILDING FACILITIES - CHECK LOCAL CODES.



Model 111-1.6



**Regal® Model
Flushometer**

110
111

► **Description**

Exposed Water Closet Flushometer, for floor mounted or wall hung top spud bowls

► **Flush Cycle**

- Model 110 Water Saver (3.5 gpf/13.2 Lpf)
- Model 111 Low Consumption (1.8 gpf/6.0 Lpf)

► **Specifications**

Quiet, Exposed, Diaphragm Type, Chrome Plated Closet Flushometer with the following features:

- ADA Compliant Metal Oscillating Non-Hold-Open Handle
- 1" I.P.S. Screwdriver Bak-Chek™ Angle Stop
- Vandal Resistant Stop Cap
- Adjustable Tailpiece
- Vacuum Breaker Flush Connection
- Spud Coupling, Wall and Spud Flanges for 1/2" Top Spud
- High Copper, Low Zinc Brass Castings for Dezincification Resistance
- Non-Hold-Open Handle and No External Volume Adjustment to Ensure Water Conservation
- Low Consumption flush accuracy controlled by Para-Flo™ Technology
- Handle Packing, Stop Seat and Vacuum Breaker to be Molded from PERMEX™ Rubber Compound for Chloramine Resistance

Valve Body, Cover, Tailpiece and Control Stop shall be in conformance with ASTM Alloy Classification for Semi-Red Brass. Valve shall be in compliance to the applicable sections of ASSE 1037, ANSI/ASME 112.19.6, and Military Specification V-29193

► **Variations**

- TP** Trap Primer
- YB** Sweat Solder Adapter Kit with Stamped Flange
- YBYC** Sweat Solder Adapter & Cast Wall Flange w/Set Screw
- YO** Bumper on Angle Stop

XL Regal XL

Flushometer includes ADA Compliant Handle, Vandal Resistant Stop Cap with Set Screw, and Sweat Solder Adapter with Cover Tube and Cast Set Screw Wall Flange

See Accessories Section of the Sloan catalog for details on these and other Flushometer variations.

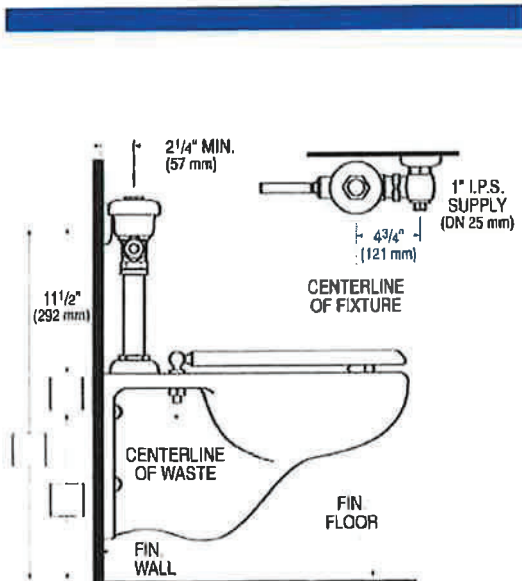

This space for Architect/Engineer approval



Made in the U.S.A
SLOAN VALVE COMPANY • 10500 SEYMOUR AVE. • FRANKLIN PARK, IL 60131
Ph: 1-800-9-VALVE-9 or 1-847-671-4300 • Fax: 1-800-447-8329 or 1-847-671-4380
<http://www.sloanvalve.com>



COMMERCIAL PLASTIC SEATS

MODEL 295C

- ELONGATED SEAT, OPEN FRONT LESS COVER
- SOLID PLASTIC
- POSTUREPEDIC CONTOUR DESIGN
- CONCEALED 300 SERIES STAINLESS STEEL CHECK HINGES

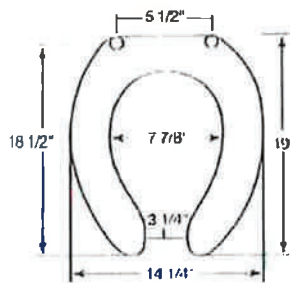

Ring thickness is 13/16"
 Ring thickness including the bumper is 1"
 Height of Seat is 2-1/4"

Seats shall be No. **295C** as manufactured by Church Seats. Seats shall be heavy weight and injection-molded of solid plastic. Seats shall be open front less cover for elongated bowl and feature exclusive Posturepedic contour design and four large molded-in bumpers. Concealed check hinges to feature 300 Series stainless steel posts that stop seat 11 degrees beyond vertical. Uses 300 Series stainless steel hardware. Color to be _____. (specify white or fixture manufacturer's color) Hinges shall be _____. (specify hinge type)

295C Concealed check hinge stops seat 11° beyond vertical.

295SSC Self-sustaining, concealed stainless steel check hinge holds seat in any raised position up to 11° beyond vertical.

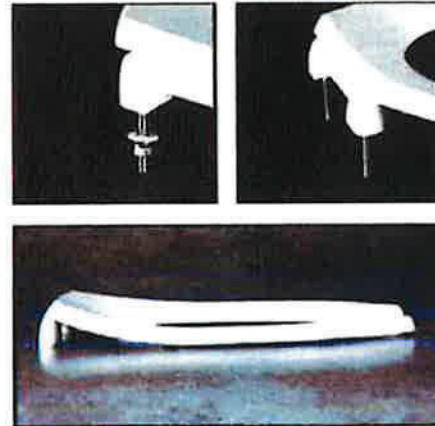

American Standard

 **BARRIER FREE**

LUCERNE™
WALL-HUNG LAVATORY
 VITREOUS CHINA

LUCERNE™ WALL-HUNG LAVATORY

- Vitreous china
- Front overflow
- D-shaped bowl
- Self-draining deck area with contoured back and side splash shields
- Faucet ledge

Faucet holes on 203mm (8") centers (illus.):

- 0356.028** For exposed bracket support
Shown with 4801.862 Amaris Heritage faucet with Triune Cross handles (not included)
- 0356.015** For wall hanger (included) or concealed arms support
- 0356.037** For wall hanger (included) or concealed arms support
 - Extra right-hand hole
- 0356.073** For wall hanger (included) or concealed arms support
 - Extra left-hand hole

Faucet holes on 102mm (4") centers:

- 0355.027** For exposed bracket support
- 0355.012** For wall hanger (included) or concealed arms support
- 0355.034** For wall hanger (included) or concealed arms support
 - Extra right-hand hole
- 0355.056** For wall hanger (included) or concealed arms support
 - Extra left-hand hole

Single center faucet hole (illus.):

- 0356.041** for exposed bracket support
Shown with 1340.000 metering faucet (not included)
- 0356.421** for wall hanger (included) or concealed arms support
- 0356.137** For wall hanger (included) or concealed arms support
 - Extra right-hand hole
- 0356.115** For wall hanger (included) or concealed arms support
 - Extra left-hand hole

Nominal Dimensions:
 521 x 464mm (20-1/2" x 18-1/4")

Bowl sizes:
 381mm (15") wide, 254mm (10") front to back,
 165mm (6-1/2") deep

Compliance Certifications -
Meets or Exceeds the Following Specifications:
 • ASME A112.19.2 for Vitreous China Fixtures

 **Top of front rim mounted 864mm (34") from finished floor. MEETS THE AMERICAN DISABILITIES ACT GUIDELINES AND ANSI A117.1 ACCESSIBLE AND USEABLE BUILDINGS AND FACILITIES - CHECK LOCAL CODES.**

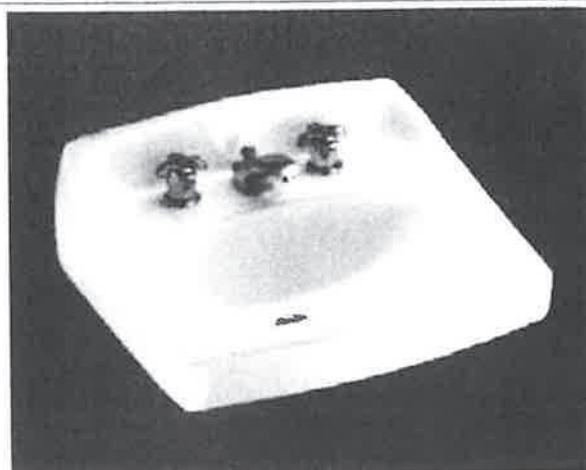

0356.028



0356.041

To Be Specified

- Color:** White Bone Silver Black
- Shell**
- Faucet*:** **Faucet Finish:**
- Supplies:** **1-1/4" Trap:**
- Nipple:**
- Bracket Support (by others):**
- Concealed Arms Support (by others):**

* See faucet section for additional models available

NOTE: Roughing-in information shown on reverse side of page



LUCERNE™
WALL-HUNG LAVATORY
VITREOUS CHINA



0355.012 4" CTRS FOR WALL HANGER OR CONCEALED ARMS

0355.034 4" CTRS FOR WALL HANGER OR CONCEALED ARMS
EXTRA RIGHT HAND HOLE

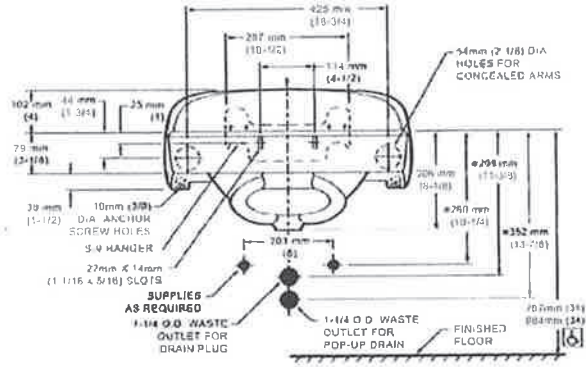
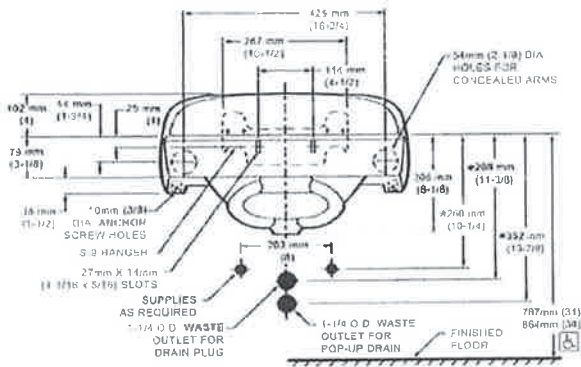
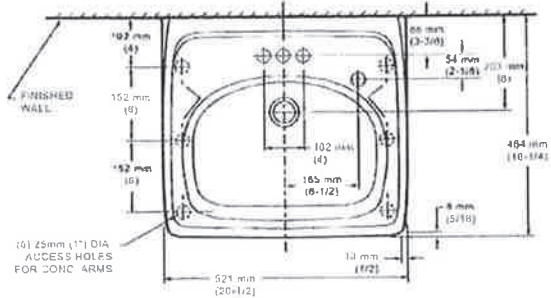
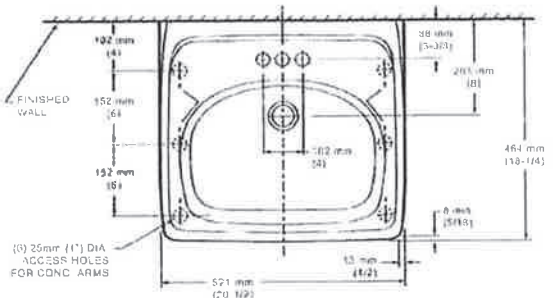

0355.056 4" CTRS FOR WALL HANGER OR CONCEALED ARMS
EXTRA LEFT HAND HOLE

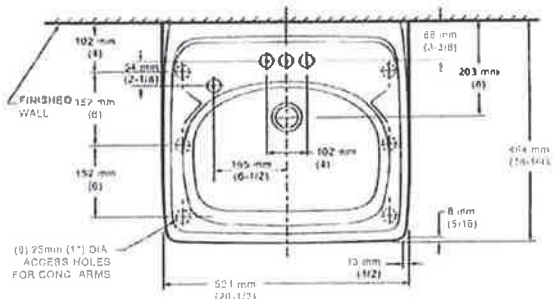

NOTES:
* DIMENSIONS SHOWN FOR LOCATION OF SUPPLIES AND "P" TRAP ARE SUGGESTED.
LAVATORY DESIGNED TO MEET ADA HANDICAPPED GUIDELINES WITH MOUNTING HEIGHT SET AT 864MM (34") ABOVE FINISHED FLOOR. PROVIDE SUITABLE REINFORCEMENT FOR ALL WALL SUPPORTS. FITTINGS NOT INCLUDED AND MUST BE ORDERED SEPARATELY. CONCEALED ARM SUPPORT AS REQUIRED TO BE FURNISHED BY OTHERS. IMPORTANT: Dimensions of fixtures are nominal and may vary within the range of tolerances established by ANSI Standard A112.19.2. These measurements are subject to change or cancellation. No responsibility is assumed for use of superseded or voided pages.

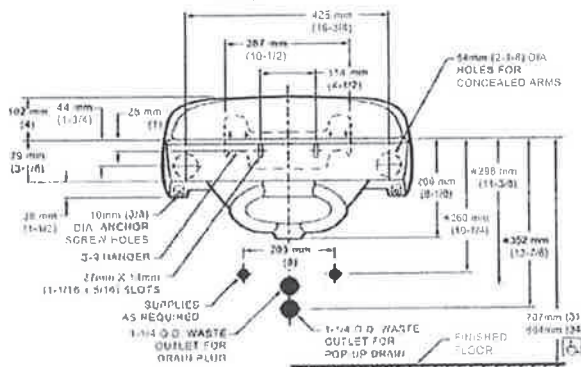

SMITH® JAY R. SMITH MFG. CO.®
 DIVISION OF SMITH INDUSTRIES, INC.
 POST OFFICE BOX 3237
 BIRMINGHAM, ALABAMA 35109-0237 (USA)
 TEL: 334-277-5520 FAX: 334-272-7396 www.jrsmith.com



LOCATION
 0700-M19

H
 DRAWING NUMBER S0700
 SIZE A
 SCALE: NONE
 DATE: 2-20-85
 APPROVED BY: SJM
 CHECKED BY: SJM
 DRAWN BY: CR
 FIGURE NUMBER 0700

WE CAN ASSUME NO RESPONSIBILITY FOR USE OF SUPERSEDED OR VOID DATA
 DIMENSIONS ARE SUBJECT TO MANUFACTURERS TOLERANCE AND CHANGE WITHOUT NOTICE

**LAVATORY SUPPORTS
 WITH CONCEALED ARMS**

FLOOR MOUNTED WITH "PRO-SET" UPRIGHTS

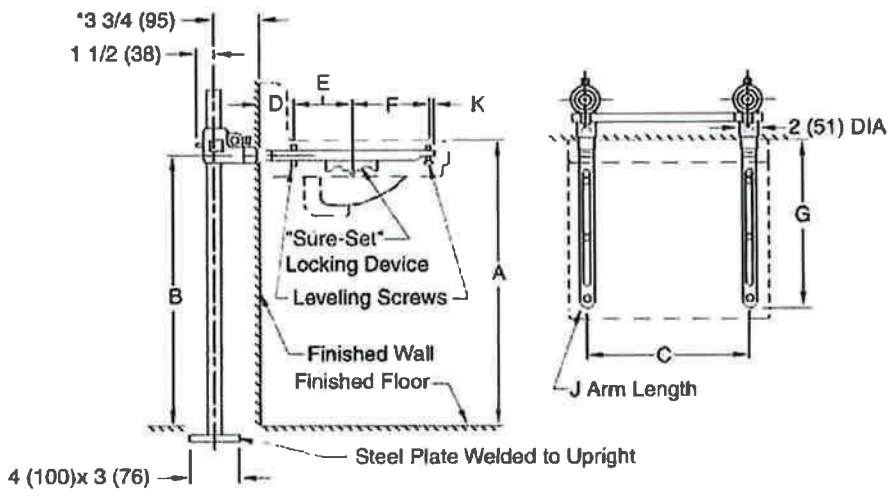
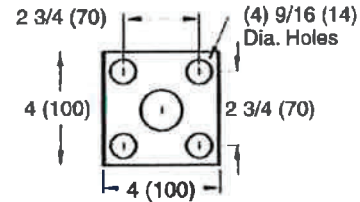

Fig. 0700 ... FOR HIGH BACK LAVATORIES (shown)

NOTE: The rough-in dimensions listed on this drawing are based on current information available to Jay R. Smith by the fixture manufacturers. We recommend that you verify these dimensions with the fixture manufacturer. We will not accept responsibility for rough-in dimension changes by the fixture manufacturer.

NOTE: Dimensions shown in parentheses are in millimeters.



BASE DETAIL

ROUGHING-IN TABLE

FIXTURE MFG.	NAME	NUMBER	SIZE	A	B	C	D	E	F	G	J	K
AM. STD.	LUCERNE	0355.012	20 (510) x 18 (455)	31 (785)	29 1/4 (745)	18 3/4 (425)	4 (100)	6 (150)	6 (150)	16 1/2 (420)	19 (485)	1/2 (13)
AM. STD.	LUCERNE	0356.015	20 (510) x 18 (455)	31 (785)	29 1/4 (745)	16 3/4 (425)	4 (100)	6 (150)	6 (150)	16 1/2 (420)	19 (485)	1/2 (13)
AM. STD.	LUCERNE	0356.421	20 (510) x 18 (455)	31 (785)	29 1/4 (745)	16 3/4 (425)	4 (100)	6 (150)	6 (150)	16 1/2 (420)	19 (485)	1/2 (13)
AM. STD.	LUCERNE	0356.436	20 (510) x 18 (455)	31 (785)	29 1/4 (745)	16 3/4 (425)	4 (100)	6 (150)	6 (150)	16 1/2 (420)	19 (485)	1/2 (13)
AM. STD.	MURRO	0954.000	22 (560) x 21 (536)	34 (865)	32 3/8 (823)	16 3/4 (425)	4 (100)	6 (150)	4 (100)	14 1/2 (370)	17M (430)	1/2 (13)
AM. STD.	MURRO	0955.000	22 (560) x 21 (536)	34 (865)	32 3/8 (823)	16 3/4 (425)	4 (100)	6 (150)	4 (100)	14 1/2 (370)	17M (430)	1/2 (13)
AM. STD.	MURRO	0958.000	22 (560) x 21 (536)	34 (865)	32 3/8 (823)	16 3/4 (425)	4 (100)	6 (150)	4 (100)	14 1/2 (370)	17M (430)	1/2 (13)
CRANE	HARWICH	1-412	20 (510) x 18 (455)	31 (785)	29 1/4 (745)	16 1/4 (415)	4 (100)	5 5/8 (143)	4 3/8 (111)	16 1/2 (420)	18 (455)	2 1/2 (64)
ELJER	DELWYN	051-1634, 1838	18 (455) x 15 (380)	31 (785)	29 1/4 (745)	15 1/2 (395)	3 (76)	5 (125)	4 3/4 (120)	13 1/2 (346)	7M (430)	3/4 (19)
ELJER	SIGNATURE	051-2101, 4, 8	20 (510) x 18 (455)	34 (865)	32 (815)	17 (430)	4 (100)	5 5/8 (143)	5 5/8 (143)	15 3/4 (400)	18 (455)	1/2 (13)
KOHLER	GREENWICH	K-2030, 1, 2, 4, 6	20 (510) x 18 (455)	31 (785)	29 (735)	17 1/4 (440)	3 1/4 (83)	5 1/4 (135)	5 1/4 (135)	14 1/4 (360)	18 (405)	1/2 (13)
KOHLER	SOHO	K-2053, 4	20 (510) x 18 (455)	31 (785)	29 1/4 (745)	16 1/2 (420)	3 1/4 (83)	5 1/4 (135)	5 1/4 (135)	14 1/4 (360)	17M (430)	1/2 (13)
U. RUNDLE	NEW CAMDEN	4848, 9	20 (510) x 18 (455)	31 (785)	29 3/8 (748)	16 1/4 (415)	4 1/2 (115)	2 1/2 (64)	4 (345)	13 1/2 (345)	16 (405)	2 1/2 (64)

NOTE: *This dimension can be increased when fixture support is to be installed behind the wall. (Specify when required and wall thickness).

REV.	DATE	DESCRIPTION	BY	CKD. BY	WEIGHT POUNDS	VOLUME CUBIC FEET	FIGURE NUMBER
H	11/23/05	Revised Roughing-in Table	JJ	CL			0700
G	03/19/04	Revised Roughing-in Table	JJ	CL			

D
 DRAWING NUMBER S0700 INS
 SIZE A
 SCALE NONE
 DATE 8-8-85
 APPROVED BY KG
 CHECKED BY CR
 DRAWN BY VGD
0700, 0700 (-E) INSTALLATION INSTRUCTIONS
 DIMENSIONS ARE SUBJECT TO MANUFACTURERS TOLERANCE AND CHANGE WITHOUT NOTICE

SMITH® JAY R. SMITH MFG. CO.®
 DIVISION OF SMITH INDUSTRIES, INC.
 POST OFFICE BOX 3717
 MONTGOMERY, ALABAMA 36109-0717 (USA)
 TEL 334-277-8520 FAX 334-272-7398 www.smith.com



LOCATION

INSTALLATION INSTRUCTIONS FOR CONCEALED ARM CARRIERS

BEFORE starting rough-in be certain you:

- know correct fixture number and name
- have a copy of Smith submittal (rough-in) drawing with dimensions for fixture to be used.

NOTE: The rough-in dimensions listed on this drawing are based on current information available to Jay R. Smith by the fixture manufacturers. We recommend that you verify these dimensions with the fixture manufacturer. We will not accept responsibility for rough-in dimension changes by the fixture manufacturer.

PART	QTY	DESCRIPTION
1	2	Upright (w/welded base)
2	2	Sleeve Assembly
3	1	Alignment Bar
4	2	Locking Coupling
5	2	Escutcheon Fig. 0700 (-E)
6	2	Arm Assembly
6a	2	Rear Leveling Screw Assy
6b	2	Locking Device
6c	2	Front Leveling Screw

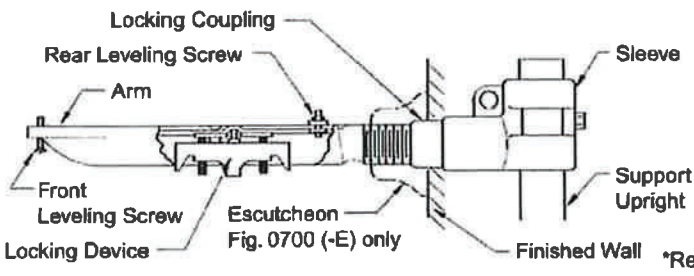
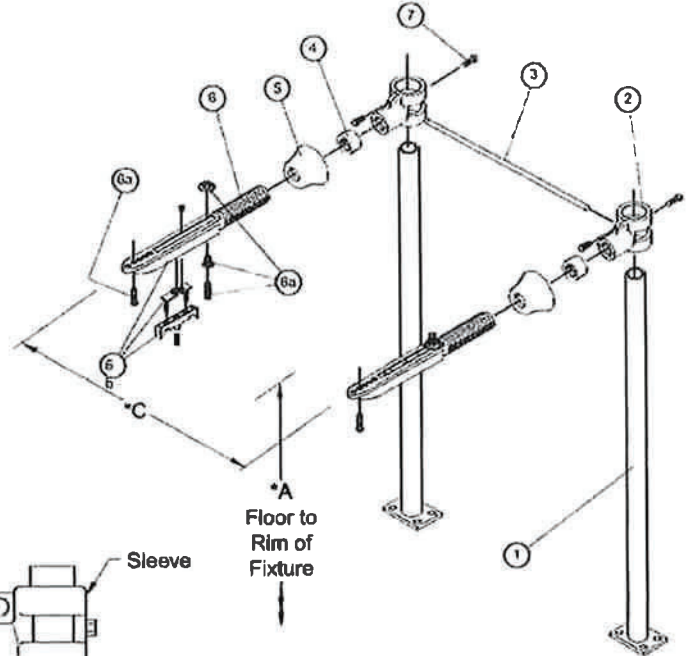

*Refer to Smith submittal drawing for these dimensions.

INSTALLATION INSTRUCTIONS FOR CONCEALED ARM CARRIERS

- Uprights (Part #1) must be spaced according to the "C" dimension (shown on the submittal drawing). Uprights should not be bolted rigidly to the floor at this time.
- Position sleeves (Part #2) by using the "B" dimension (shown on the submittal drawing). Secure to uprights with 5/16 (8)-18 hex head bolts (furnished) on the back of the sleeve.
- Slide alignment bar (Part #3) into the sleeves. Recheck the "C" dimension at the center of the uprights. Secure the alignment bar with 5/16 (8) hex head bolts (furnished). Uprights should now be bolted securely to the floor. Uprights must be plumb; if necessary, shim to compensate for uneven floors.
- Thread escutcheon (Part #5), Fig. 0700 (-E) only onto arm (Part #6). Thread locking coupling (Part #4) onto arm. Thread arms into sleeves (Part #2) to dimension "G" (shown on the submittal drawing). Lock arms in place by tightening locking coupling (Part #4). Recheck "C" dimension at the end of the arms.
- Rear leveling screw assemblies (Part #6a) must be set according to the "D" dimension (shown on the submittal drawing). Position the locking devices (Part #6b) to the "E" dimension (shown on the submittal drawing). Install the front leveling screws (Part #6c) to the "E" dimension (shown on the submittal drawing).
- Level lavatory with leveling screws as required and secure in place with locking device.

REV.	DATE	DESCRIPTION	BY	CKD. BY	WEIGHT POUNDS	VOLUME CUBIC FEET	FIGURE NUMBER
	2/18/01	Revised Submittal	RN				0700, 0700 (-E) INSTALLATION INSTRUCTIONS
	01/11/00	Revised Base Plate	JJ				
	6-7-95	Added Millimeters	EMB				
	9-27-94	Submittal Update	EMB				



JAY R. SMITH MFG. CO.
 DIVISION OF SMITH INDUSTRIES, INC.
 4021 OFFICE BLDG 1517
 MOBILE/ALABAMA 36684-0752 (USA)
 TEL. 334-272-6500 FAX. 334-272-7395 www.jrsmith.com



LOCATION

LAVATORY SUPPORTS WITH CONCEALED ARMS

FLOOR MOUNTED WITH "PRO-SET" UPRIGHTS

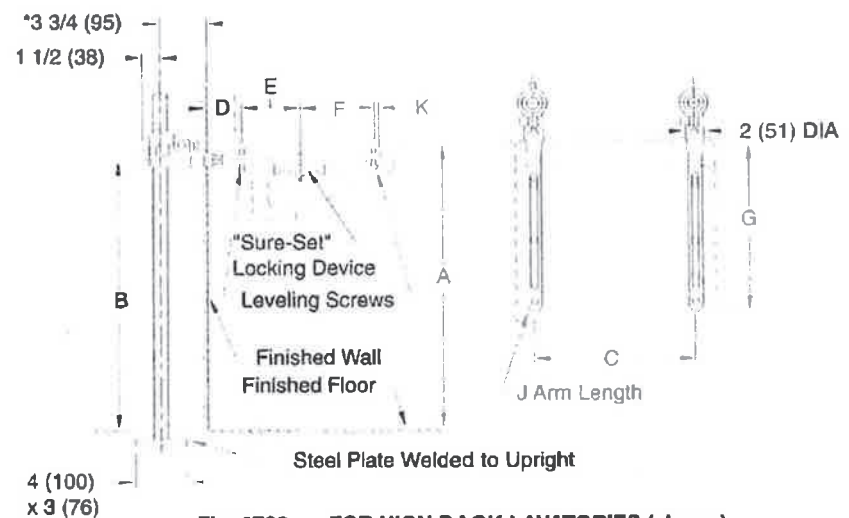
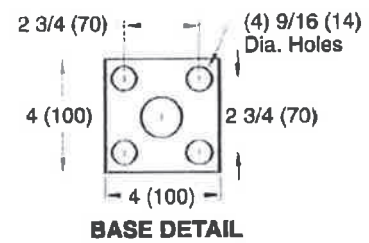

Fig. 0700 ... FOR HIGH BACK LAVATORIES (shown)

NOTE: The rough-in dimensions listed on this drawing are based on current information available to Jay R. Smith by the fixture manufacturers. We recommend that you verify these dimensions with the fixture manufacturer. We will not accept responsibility for rough-in dimension changes by the fixture manufacturer.

NOTE: Dimensions shown in parentheses are in millimeters.

NOTE: Front leveling screws should protrude 1"(25) above arms.



BASE DETAIL

ROUGHING-IN TABLE

FIXTURE NAME		NUMBER		SIZE				
A	B	C	D	E	F	G	J	K

NOTE: *This dimension can be increased when fixture support is to be installed behind the wall. (Specify when required and wall thickness).

DRAWING NUMBER
S0700 (B)

SIZE
A

SCALE:
NONE

DATE:
9-11-63

APPROVED BY:

CHECKED BY:
RP

DRAWN BY:
SL

0700

DIMENSIONS ARE SUBJECT TO MANUFACTURERS TOLERANCE AND CHANGE WITHOUT NOTICE. WE CAN ASSUME NO RESPONSIBILITY FOR USE OF SUPERSEDED OR VOID DATA.

FIGURE NUMBER	H	02/25/02	Revised Submittal	JJ	CR	WEIGHT POUNDS	VOLUME CUBIC FEET	FIGURE NUMBER
	G	2/20/01	Revised Submittal	RN	BS			
REV.	DATE	DESCRIPTION		BY	CKD. BY			

METERING FAUCETS

802-335ABCP



Manual and Metering Faucets

Product Type

Deck Mounted 4" Fixed Centers Hot and Cold Water
Metering Sink Faucet

Features & Specifications

- 4" Fixed Centers
- 2.2 GPM (8.3 L/min) Aerator
- 1-1/2" Vandal Proof Push-tilt Handle
- NAIAD Metering Adjustable Cycle Time Closure Cartridge
- 1/2" NPSM Supply Inlets and Coupling Nut for 3/8" or 1/2" Flexible Riser
- 4" Center to Center Integral Cast Brass Spout
- ECAST® design provides durable brass construction with total lead content equal to or less than 0.25% by weighted average

Performance Specification

- Rated Operating Pressure: 20-125 PSI
- Rated Operating Temperature: 40-140°F

Warranty

- Lifetime Limited Faucet Warranty
- 5-Year Limited Cartridge Warranty
- 1-Year Limited Finish Warranty

Codes & Standards

- ASME A112.18.1/CSA B125.1
- Certified to NSF/ANSI 61, Section 9 by CSA

Job Name _____

Item Number _____

Section/Tag _____

Model Specified _____

Architect _____

Engineer _____

Contractor _____

Submitted as Shown Submitted with Variations

Date _____



ECAST

ECAST products are intended for installation where state laws and local codes mandate lead content levels or in any location where lead content is a concern.



2100 South Clearwater Drive
Des Plaines, IL
P: 847/803-5000
F: 847/803-5454
Technical: 800/TEC-TRUE
www.chicagofaucets.com

802-335ABCP

Manual and Metering Faucets



Architect/Engineer Specification

Chicago Faucets No. 802-335ABCP, Deck Mounted 4" Fixed Centers Hot and Cold Water Metering Sink Faucet, Chrome Plated solid brass construction. 4" Center to Center Integral Cast Brass Spout. 2.2 GPM (8.3 L/min) Pressure Compensating Softfo Aerator. 1-1/2" Metal Vandal Proof Push-tilt handle(s) with Twenty Point Broach and C and H Index. NAIAD™ rebuildable auto-timed metering cartridge, adjustable run time from 2 to 15 seconds, opens with push, 0.20 max gallon/cycle. 1/2" NPSM Supply Inlets and Coupling Nut for 3/8" or 1/2" Flexible Riser. ECAST® construction with less than 0.25% lead content by weighted average. Secondary Control Valve: 4" Center to Center Integral Cast Brass Spout. This product is tested and certified to industry standards: ASME A112.18.1/CSA B125.1, and Certified to NSF/ANSI 61, Section 9 by CSA.

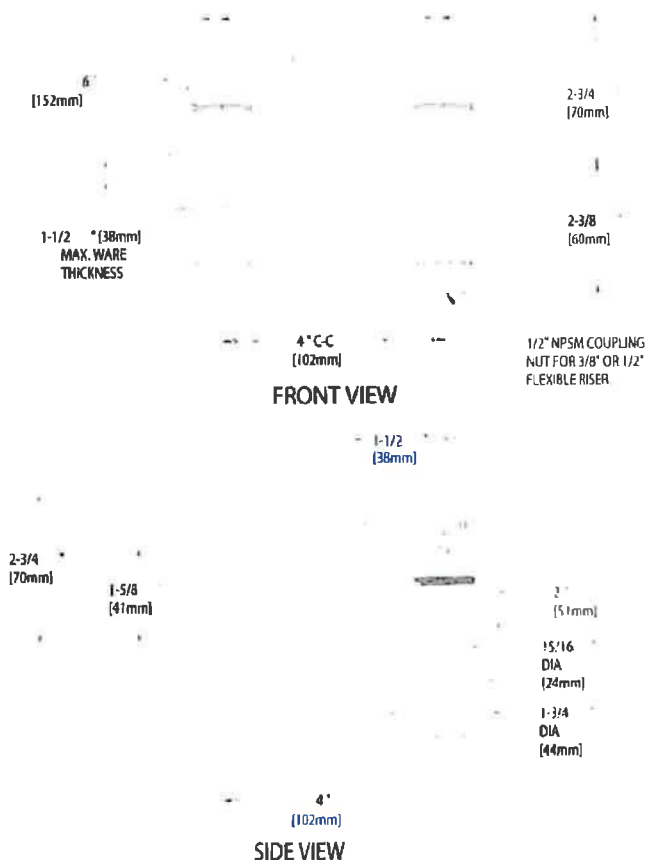

Operation and Maintenance

Installation should be in accordance with local plumbing codes. Flush all pipes thoroughly before installation. After installation, remove spout outlet or flow control and flush faucet thoroughly to clear any debris. Care should be taken when cleaning the product. Do not use abrasive cleaners, chemicals or solvents as they can result in surface damage. Use mild soap and warm water for cleaning and protecting the life of Chicago Faucet products. For specific operation and maintenance refer to the installation instructions and repair parts documents that are located at www.chicagofaucets.com.

Chicago Faucets, member of the Geberit Group, is the leading brand of commercial faucets and fittings in the United States, offering a complete range of products for schools, laboratories, hospitals, office buildings, food service, airports and sport facilities. Call 1.800.TECTRUE or 1.847.803.5000 Option 1 for installation or other technical assistance.



2100 South Clearwater Drive
Des Plaines, IL
P: 847/803-5000
F: 847/803-5454
Technical: 800/TEC-TRUE
www.chicagofaucets.com

For Residential and Commercial Applications

Job Name _____ Contractor _____
 Job Location _____ Approval _____
 Engineer _____ Contractor's P.O. No. _____
 Approval _____ Representative _____

LEAD FREE

Series LFUSG-B Under Sink Guardian®

The LFUSG-B-M2 Under Sink Guardian® 3/8" (10mm) compression and Quick-Connect fitting thermostatic mixing valves maintain and limit hot water to desired selectable temperature between 80°F and 120°F (27°C and 49°C) with flow rates as low as 0.5 gpm (1.9 lpm) and as high as 2.25 gpm (8.5 lpm). The mixing valve is listed to ASSE Standard 1070 for single fixture applications and IAPMO cUPC. The LFUSG-B-M2 features Lead Free* construction to comply with Lead Free* installation requirements. The superior flow characteristics of these valves provide temperature control with low pressure drop. As an added feature, the LFUSG-B-M2 incorporates dual check valves to protect against cross-flow and integral screens to filter out debris.

Features

- Lead Free* Brass body construction
- Installs easily between the stop valves and faucet
- Includes tamper resistant locking nut to prevent accidental mis-adjustment
- Built-in check valves prevent migration of hot water to cold and cold water to hot water piping
- Provided with cap for three port application
- Integral strainer with 40 mesh stainless steel screens to filter out debris

Applications

The unit is intended for under sink installation to control the hot water temperature and minimize the occurrence of accidental scalding. The water temperature must be adjusted by the installer using a thermometer to measure the hot water temperature at the faucet outlet. Maximum temperature of 105°F (41°C) is recommended.

Specifications

A Thermostatic Mixing Valve shall be installed on the hot water supply to the fixture. The valve shall be ASSE Standard 1070 and IAPMO cUPC listed and control the temperature of the hot water. It shall have a Lead Free* brass 4-port, "H" pattern body. Lead Free* under counter thermostatic valves shall comply with state codes and standards, where applicable, requiring reduced lead content. The valve shall include integral check valves, integral screens and an adjustment nut with locking feature. The valve shall be provided with 3/8" (10mm) male compression or Quick-connect fittings. The valve shall be Watts Series LFUSG-B.

For satin chrome finish specify – SC.



LFUSG-B-M2

LFUSG-B-QC-M2

ASSE 1070 & IAPMO cUPC Listed

Materials

Body: Lead Free* Brass

Rubber Disc: Buna-N

O-rings: Buna-N

Spring: Stainless steel

Piston: Noryl®

Thermostat: Copper

Approval



ASSE 1070

Pressure – Temperature

Minimum supply pressure: 30psi (207 kPa)

Hot inlet temperature: 120°F-180°F (49°C-82°C)

Cold inlet temperature: 39°F-80°F (3.8°C-27°C)

Minimum inlet temperature differential: 5°F (2.8°C)

Temperature range: 80°F-120°F (27°C-49°C)

Maximum pressure: 150psi (10.3 bar)

Minimum Flow: 0.5 gpm (2.2 l/m)

*The wetted surface of this product contacted by consumable water contains less than one quarter of one percent (0.25%) of lead by weight.

Noryl® is a registered trademark of SABIC Innovative Plastics®

Watts product specifications in US customary units and metric are approximate and are provided for reference only. For precise measurements, please contact Watts Technical Service. Watts reserves the right to change or modify product design, construction, specifications, or materials without prior notice and without incurring any obligation to make such changes and modifications on Watts products previously or subsequently sold

Basic Construction

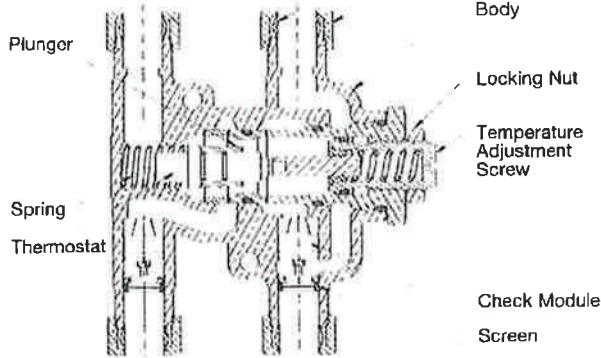

Flow Capacity

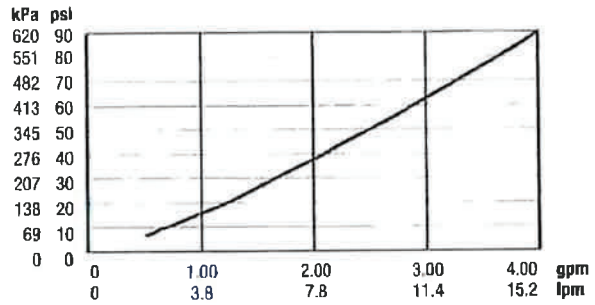

Dimensions – Weights

MODEL	SIZE	DIMENSIONS								WEIGHT	
		A		B		C		D		lbs	kgs
		in.	mm	in.	mm	in.	mm	in.	mm		
LFUSG-B-M2	3/8" Comp.	3 3/16	81	3 3/8	85	1 13/16	47	1 1/2	38	.82	.37
LFUSG-B-SC-M2	3/8" Comp.	3 3/16	81	3 3/8	85	1 13/16	47	1 1/2	38	.82	.37
LFUSG-B-QC-M2	3/8" Quick Connect	3 1/4	83	4	102	2 1/4	57	1 1/2	38	1.05	.48
LFUSG-B-QC-SC-M2	3/8" Quick Connect	3 1/4	83	4	102	2 1/4	57	1 1/2	38	1.05	.48

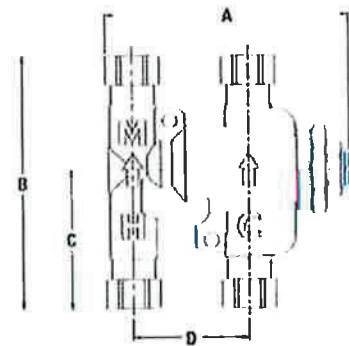

Typical Installations

Two Handle Faucet



Sensor Faucet

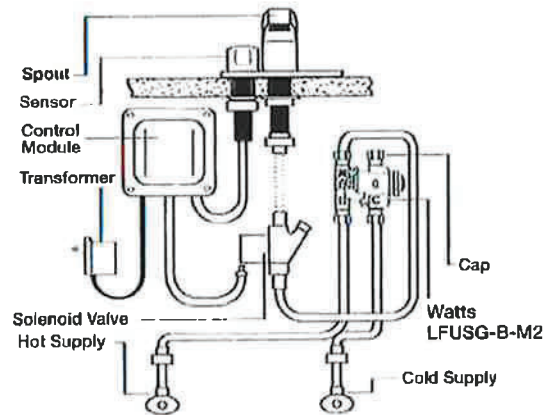

NOTE: This information is not intended to replace the full product installation and safety information available or the experience of a trained product installer. You are required to thoroughly read all installation instructions and product safety information before beginning the installation of this product.

WATTS

A Watts Water Technologies Company



ISO 9001-2008
CERTIFIED

USA: No. Andover, MA • Tel. (978) 688-1811 • Fax: (978) 794-1848 • www.watts.com
Canada: Burlington, ON • Tel. (905) 332-4090 • Fax: (905) 332-7068 • www.wattscanada.ca



LAV GUARD²
FAST FIT UNDERSINK PIPING COVERS

Model 102-E-Z



ADA-compliant undersink protection



Submittal Sheet

General Description:

LAV GUARD² E-Z Series waste and supply piping covers satisfy ADA compliance requirements. Built-in E-Z Grip internal fasteners and internal, E-Z Tear-To-Fit trimming feature allow for fast installation without tools. Series #100 E-Z kits are designed to fit on all tubular and cast brass P-trap assemblies. Series #400 kits are the "original" LAV GUARD design and fit schedule 40 ABS and PVC P-trap assemblies — regardless of their geometry or rotational offset. Valve cover completely encloses angle valve and supply tube for both handled and keyed type water stops.

Material	Molded vinyl
Nominal Wall	1/8" constant
Durometer	70 - 80 - Shore A
UV Protection	Will not fade or discolor
Durability	Virtually indestructible
Trimming (E-Z Series)	Internal, E-Z Tear-To-Fit trim feature
Fasteners (E-Z Series)	Internal E-Z Grip fasteners (reusable)
Color	China white
Paintability	Apply Latex paint
Burning Characteristics ASTM D-635	Self extinguished 0 sec (ATB) 0 mm (AEB)
Bacteria/Fungus Resistance	ASTM G21 and G22/ Result: 0 growth
Maintenance	Use common detergents

Manufactured under one or more of the following U.S. or Canadian patents. Other patents pending.
5,303,730 5,360,031 5,524,669 5,564,463 5,676,598 5,699,828 5,915,412
5,915,413 5,901,739 5,960,820 2,075,324 2,119,427 2,136,027 2,158,083



IPS Corporation, 202 Industrial Park Lane, Collierville, TN 38017
(901) 853-5001 (800) 340-5969 FAX: (901) 853-5008
e-mail: info@truebro.com Internet: http://www.truebro.com

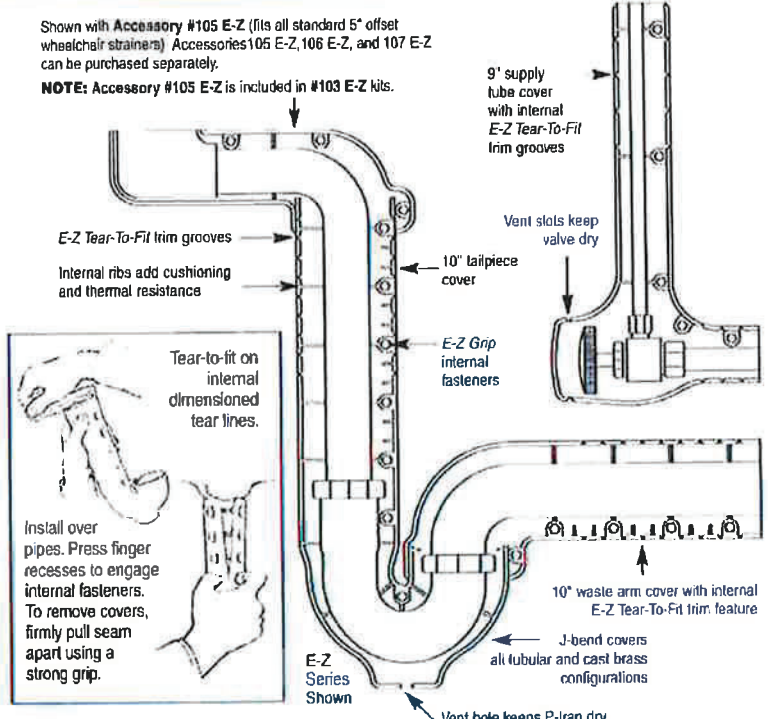

#100 E-Z Series (shown above right) for tubular and cast brass P-trap assemblies.
#400W* Series (original design) for schedule 40 P-trap assemblies.

- | | | |
|---|---|--|
| <input type="checkbox"/> Model #99 E-Z
One angle valve and supply cover | <input type="checkbox"/> Model #102 E-Z
One P-trap cover, two angle valves and covers | <input type="checkbox"/> Accessory #105-K
Kohler 6" offset |
| <input type="checkbox"/> Model #100 E-Z
One P-trap cover | <input type="checkbox"/> Model #402W*
One P-trap cover, two angle valves and covers | <input type="checkbox"/> Accessory #106 E-Z
One basket strainer cover and offset waste cover (adjustable to 18") |
| <input type="checkbox"/> Model #400W*
One P-trap cover | <input type="checkbox"/> Model #103 E-Z
One P-trap cover, two angle valves and supply covers, one 5" offset tailpiece wheelchair strainer cover | <input type="checkbox"/> Accessory #107 E-Z
Two basket strainer covers and center or end outlet waste cover (adjustable) |
| <input type="checkbox"/> Model #101 E-Z
One P-trap cover, one angle valve cover | <input type="checkbox"/> Accessory #105 E-Z
One 5" offset tailpiece wheelchair strainer assembly | <input type="checkbox"/> Accessory #Ex99 E-Z
One 16" extension for water supply |
| <input type="checkbox"/> Model #401W*
One P-trap cover, one angle valve cover | | <input type="checkbox"/> Accessory #Ex100 E-Z
One 16" extension for drain waste arm or tailpiece |

*All #400W series items are the "original" Lav Guard² design and construction. Specifications may change without notice.

<input type="checkbox"/> Accessory 105 E-Z	<input type="checkbox"/> Accessory 107 E-Z (Configuration Options Shown)
<input type="checkbox"/> Accessory 106 E-Z	<input type="checkbox"/> Center Outlet
	<input type="checkbox"/> End Outlet

Job/Location _____
Designer _____

ON-GRADE ADJUSTABLE FLOOR DRAIN

832 series

Finish Line™

SPECIFICATION

Sioux Chief 832 series Finish Line adjustable on-grade floor drain shall be used where necessary in drainage systems. Floor drain shall allow adjustment of 1.25" before the concrete pour, and 1.25" after the concrete pour. Floor drain shall have a Sch. 40 hub connection, which conforms to ASTM D2665 (PVC) or D2661 (ABS). Connection to drainage system shall be made with a solvent weld joint to ABS/PVC pipe. Strainer of floor drain shall be nickel-bronze and shall fasten into female threaded brass inserts. Strainer shall meet applicable load requirements for intended use. Trap primer port shall be threaded 1/2" FIP for knockout connection.

MATERIALS

ring/strainer: nickel-bronze
 head adapter: ABS with threaded brass inserts
 coring sleeve: ABS
 coring plug: high-impact polymer
 base adapter: ABS or PVC

STRAINER LOAD RATING

1,000 lbs. (light duty, pedestrian traffic)

STRAINER FREE-AREA

round: 11.75 in²
 square: 16.4 in²

DIMENSIONS

A: connection size 2", 3", or 4" Sch. 40 hub
 B: ring/strainer diameter
 round 6 1/2"
 square 7 1/8"
 C: adapter height
 2" hub 4 5/8"
 3" hub 4 3/8"
 4" hub 4 5/8"
 D: pre-pour adjustable height
 2" hub 5 1/2" - 6 3/4"
 3" hub 5 1/4" - 6 1/2"
 4" hub 5 1/2" - 6 3/4"
 E: post-pour adjustable height 0" - 1 1/4"
 F: trap primer port 1/2" FIP thread for knockout connection
 *2" hub connection is factory installed 2" x 3" bushing in 3" hub model.

Item # Submitted	832-36PNR
Job Name	_____
Location	_____
Engineer	_____
Contractor	_____
PO#	TAG



832-36ANR

832-4PNQ

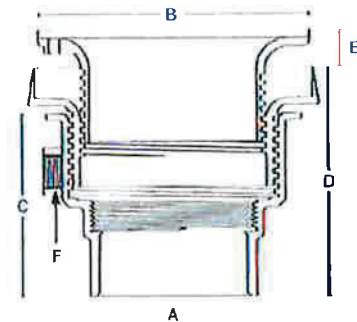

Models 832-2ANR, 832-2PNR, 832-2ANQ, 832-2PNQ, 832-36ANR, 832-36PNR, 832-36ANQ, and 832-36PNQ are UPC listed

Create Item Number

832-ABCD

e.g. 832-36PNR = Finish Line drain with 3" Sch. 40 hub connection with round nickel-bronze ring and strainer

A CONNECTION SIZE

- 2 2" Sch. 40 hub
- 36 3" Sch. 40 hub
- 4 4" Sch. 40 hub

B CONNECTION TYPE

- A ABS base adapter
- P PVC base adapter

C RING & STRAINER

- NR round nickel-bronze ring & strainer
- NQ square nickel-bronze ring & strainer

D OPTIONS (FACTORY INSTALLED)

- V vandal-resistant strainer screws
- E¹ 1 3/8" extended strainer rim

¹ Available only on round pattern strainer

ACCESSORIES

- 832-UM stainless steel debris bucket
- 832-S4 shim kit
- 863-FA 4" round aluminum condensate funnel
- 863-FN 4" round nickel-bronze condensate funnel
- 863-FNO 4" x 9" oval nickel-bronze condensate funnel

TRAP PRIMER TAILPIECE

200 series, 213 series

Trap-Ease™

SPECIFICATION

Sioux Chief 200/213 series Trap Primer tailpieces shall be used where necessary in drainage systems. Trap primer tailpiece shall be a gravity fed device with no mechanical parts. Trap primer tailpiece shall embody a 1/2" nominal branch connection. Tailpiece shall be certified by ASSE to the ASSE 1044 Standard and meet applicable drainage requirements set forth by ASSE 1044.

MATERIALS

trap primer tailpiece body: brass

trap primer tailpiece arm: copper

trap primer captured nut*: brass

*incorporated on direct connect options

note: various product offerings include chrome finish

DIMENSIONS

	200 SERIES	213 SERIES
A: Inlet	1 1/2" direct connect	1 1/4" fine thread
B: Outlet	1 1/2" slip fit	1 1/4" slip fit
C: Tailpiece	1/2" nominal	1/2" nominal
D: Height	8"	6"

Item # Submitted	_____
Job Name	_____
Location	_____
Engineer	_____
Contractor	_____
PO#	TAG _____



200-090



213-092

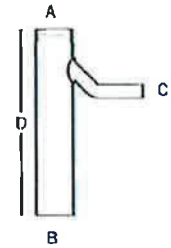
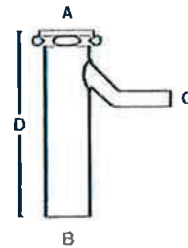

Create Item Number

2A-09B

e.g. 213-090 = Unfinished trap primer tailpiece with fine thread connection

A TUBULAR CONNECTION

00 Direct connect

13 Fine thread

B FINISH

0 Unfinished

2 Chrome

Sioux Chief

Sioux Chief Manufacturing Company • tel: 1-800-821-3944 • www.siouxchief.com • fax: 1-800-758-5950

12-10

SECTION 15810 - DUCTS AND ACCESSORIES

PART 1 - GENERAL

1.1 SECTION REQUIREMENTS

- A. Summary: Metal and nonmetal ducts and accessories in pressure classes 2 inch wg (500 Pa) or less and a maximum velocity of 2400 fpm (12 m/s).
- B. Submit Product Data for fire dampers and smoke dampers.
- C. Submit Shop Drawings detailing duct layout and including locations and types of duct accessories, duct sizes, transitions, radius and vaned elbows, special supports details, and inlets and outlet types and locations.
- D. Comply with NFPA 90A for systems serving spaces more than 25,000 cu. ft. (708 cu. m) in volume or building Types II, IV, and V construction over 3 stories in height.
- E. Comply with NFPA 90B for systems serving spaces 1- or 2-family dwellings or serving spaces less than 25,000 cu. ft. (708 cu. m).
- F. Comply with NFPA 96 for systems serving public or private cooking operations, except single-family residential usage; and includes cooking equipment exhaust hoods, grease-removal devices, exhaust ductwork, exhaust fans, dampers, fire-extinguishing equipment, and all other auxiliary or ancillary components of systems or systems that are involved in the capture, containment, and control of grease-laden cooking effluent.
- G. Comply with UL 181 and UL 181A for ducts and closures.

PART 2 - PRODUCTS

3.1 DUCTS

- A. Galvanized Sheet Steel: Lock-forming quality, ASTM A 653, G90 (ASTM A 653M, Z275) coating designation with mill phosphatized finish for exposed surfaces of ducts exposed to view.
- B. Fibrous Glass Duct Board: Comply with UL 181, Class 1, fibrous glass with fire-resistant, reinforced foil-scrim-kraft barrier, and having the air-side surface treated to prevent erosion. Thickness: 1 inch (25 mm)
- C. Duct Liner: ASTM C 1071, Type II, with an airstream surface coated with a temperature-resistant coating.
- D. Thickness: 1/2 inches (13 mm)
- E. Adhesive: ASTM C 916, Type I.

- F. Mechanical Fasteners: Galvanized steel pin, length required penetrate liner plus a 1/8-inch (3-mm) projection maximum into the airstream.
- G. Joint and Seam Tape: Comply with UL 181A.
- H. Joint and Seam Sealant: Comply with UL 181A.
- I. Rectangular Metal Duct Fabrication: Comply with SMACNA's "HVAC Duct Construction Standard" for metal thickness, reinforcing types and intervals, tie-rod applications, and joint types and intervals.
- J. Fabricate Fibrous Glass Ducts: Comply with SMACNA's "Fibrous Glass Duct Construction Standard."

3.2 ACCESSORIES

- A. Volume-Control Dampers: Factory-fabricated volume-control dampers, complete with required hardware and accessories. Single-blade and multiple opposed-blade, standard leakage rating, and suitable for horizontal or vertical applications.
- B. Fire Dampers: Factory-fabricated fire dampers, complete with required hardware and accessories. UL labeled according to UL 555, "Standard for Fire Dampers." Air Balance Models (119CL and 199 ML), or approved alternate.
- C. Ceiling Fire Dampers: Factory-fabricated fire dampers, complete with required hardware and accessories. UL listed and labeled; comply with the construction details for the tested floor/roof-ceiling assemblies as indicated in UL's "Fire Resistance Directory." Air Balance or Approved Alternate.
- D. Smoke Dampers: Factory-fabricated smoke and fire dampers, complete with required hardware and accessories. UL labeled according to UL 555S, "Standard for Leakage Rated Dampers for Use in Smoke Control Systems." Combination fire and smoke dampers shall also be UL labeled for 1-1/2-hour rating according to UL 555, "Standard for Fire Dampers." Air Balance or Approved Alternate.
- E. Flexible Connectors: Flame-retarded or noncombustible fabrics, coatings, and adhesives complying with UL 181, Class 1.
- F. Flexible Ducts: Flame-retarded or noncombustible fabrics, coatings, and adhesives complying with UL 181, Class 1.

PART 3 - EXECUTION

3.1 INSTALLATION

- A. Duct System Pressure Class: Construct and install each duct system for the specific duct pressure classification indicated.

- B. Conceal ducts from view in finished and occupied spaces.
- C. Avoid passing through electrical equipment spaces and enclosures.
- D. Dishwasher Exhaust Duct Installation: Comply with SMACNA's "HVAC Duct Construction Standards."
- E. Support and connect metal ducts according to SMACNA's "HVAC Duct Construction Standard."
- F. Support and connect fibrous glass ducts according to SMACNA's "Fibrous Glass Duct Construction Standard."
- G. Install duct accessories according to applicable portions of details of construction as shown in SMACNA standards.
- H. Install volume-control dampers in lined duct with methods to avoid damage to liner and to avoid erosion of duct liner.
- I. Install fire and smoke dampers according to manufacturer's UL-approved written instructions.
- J. Install fusible links in fire dampers.

3.2 TESTING, ADJUSTING, AND BALANCING

- A. Balance airflow within distribution systems, including submains, branches, and terminals to indicated quantities.

END OF SECTION 15810

SECTION 22 04 00

PLUMBING

PART 1 – GENERAL

1.01 SUMMARY

A. Work Included:

Furnish all labor, materials, services, testing, transportation, tools and equipment necessary for the completion of all plumbing, piping as indicated on drawings and specified herein. Work materials and equipment not indicated or specified which is necessary for the complete and proper operation of the work of this Section in accordance with the true intent and meaning of the contract documents shall be provided and incorporated at no additional cost to the Owner.

B. Related Work:

1. Mechanical: Section [23 00 00] [23 00 50] [23 00 80] [23 01 00]

1.02 QUALITY ASSURANCE

A. Unless otherwise noted, provisions including amendments thereto, of the international Plumbing Code & Boca Plumbing Code, latest edition, A.D.A. The Americans with Disabilities Act, and of the latest plumbing ordinances of the city are hereby made part of this section.

B. Conform to provisions of Section 23 00 00 & 23 00 80.

C. Nothing in the specifications or drawings shall be construed to permit deviation from the requirements of governing codes unless approval for said deviation has been obtained from the legally constituted authorities having jurisdiction and from the Owner's representative.

1.03 DRAWINGS

A. Because of the small scale drawings, it is not possible to indicate all offsets, fittings and accessories which may be required. The Contractor shall carefully investigate the conditions surrounding installation of his work, furnishing the necessary piping, fittings, valves, traps, and other devices which may be required to complete the installation.

B. The Contractor is required to coordinate all final connections to equipment being supplied by Contractor and by others before installing any piping. If there is a discrepancy, Contractor is to contact Engineer and Architect immediately before proceeding.

C. The general arrangement indicated on the drawings shall be followed as closely as possible. Coordinate with the Architectural, Structural, Mechanical and Electrical Drawings prior to installation of piping fixtures and equipment to verify adequate space available for installation of the work shown. In the event a field condition arises which makes it impossible to install the work as indicated, submit, in writing, the proposed departures to the Architect for his approval. Only when Architect's approval is given, in writing, shall Contractor proceed with installation of the work.

- D. Should the Contractor make changes in the installation differing from what is indicated on the contract drawings and not necessitated due to field conditions as indicated here in above, the Contractor shall be required to re-install the work to comply with what has been indicated on the contract drawings. Should it be impossible to re-install the work and the installation is in accordance with all governing authorities, the architect may permit the installation to remain. However, all costs incurred to revise the contract drawings by the engineer for resubmittal to the building department indicating the as-installed condition shall become the responsibility of the Contractor.
- E. In case of a difference in the specifications or between the specifications and the drawings, the Contractor shall figure the most expensive alternate and after award of contract, shall secure direction from the Architect.

1.04 Permits, INSPECTIONS AND LICENSES

All permits, inspections and licenses required by the legally constituted authorities for installation of the work according to the plans and specifications shall be obtained and paid as a part of the work of this section.

1.05 UTILITIES

- A. Refer to section 15000 for further information.

1.06 EXAMINATIONS OF PREMISES

Before bidding on this work, Contractors shall make a careful examination of the premises and shall thoroughly familiarize themselves with the requirements of the contract. By the act of submitting a proposal for the work included in this contract, the Contractor shall be deemed to have made such study and examination, and that he is familiar with and accepts all conditions of the site.

1.07 PROTECTION

- A. All work, equipment and materials shall be protected at all times. Contractor shall make good all damage caused either directly or indirectly by his own workmen. Contractor shall also protect his own work from damage. He shall close all pipe openings with caps or plugs during installation. He shall protect all his equipment and materials against dirt, water, chemical and mechanical injury. Upon completion, all work shall be thoroughly cleaned and delivered in a new condition.
- B. Contractor shall be held responsible for all damage to equipment and materials until he has received written notice from the Architect or Engineer that his work has been accepted.

1.08 LOCATIONS

- A. The locations of apparatus, piping and equipment indicated on the drawings are approximate. Piping and equipment shall be installed in such a manner as to avoid all obstruction, preserve headroom, and keep openings and passages clear. The locations of and mounting heights of all fixtures shall be coordinated with the architectural plans and room elevations.

- B. Clearances and Openings: Contractor shall cooperate and coordinate his work with all other trades to avoid conflict and permit for a neat and orderly appearance of the entire installation. The Contractor shall, in advance of the work, furnish instructions to the General Contractor as to his requirements for equipment and material installation of any kind, whether or not specifically mentioned on drawings or in the specifications, and shall include recesses, chases in walls, and all required openings in the structure. Should furnishing this information be neglected, delayed, or incorrect and additional cuttings are found to be required, the cost of the same shall be charged to this Contractor.

1.09 SUBMITTAL DATA (Refer to provisions of Section 23 00 00)

- A. Furnish, all at one time, prior to any installation, within the time noted below, six (6) copies of valid submittal data on all fixtures, material, equipment and devices. Each submitted item shall be indexed and referenced to these specifications and to put identification numbers on fixtures and equipment schedules.
- B. Manufacturers' submittal literature and shop drawings are required on all items to ensure the latest and most complete manufacturer's data is available for review. Requirements of the submittals and Engineer's submittal notes are a part of the work of this Division except that Engineer's notes may not be used as a means of increasing the scope of work of this Division.
- C. Submittals will be checked for general conformance with the design concept of the project but the review does not guarantee quantities shown and does not supersede requirements of this Division to properly install work.
- D. A list of names is not a valid submittal. To be valid, all submittals must:
 - 1. Be delivered to the Architect's office within thirty-five (35) days of award of the contract. Corrections or changes in submittals returned as inadequate or incomplete shall be accomplished within this time limit.
 - 2. Include all pertinent construction, installation, performance and technical data.
 - 3. Have all copies marked to indicate clearly the individual items being submitted.
 - 4. Have each item cross-referenced to the corresponding specified item and be marked to show how differences will be accommodated.
 - 5. Contain calculations and other detailed data justifying how the item was selected for proposal. Data must be completed enough to permit detailed comparison of every significant characteristic for which the specified item was analyzed during design.
 - 6. Include, for every item which differs in size, configuration, connections, service, accessibility or any other significant way, a drawing to the same (or larger) scale as to the pertinent portions of the contract drawings. In this drawing show a complete layout of the system except that which is identical to the contract drawings, unless the unchanged portions must be shown to indicate such things as clearances. This drawing, together with the contract design drawings must show the complete system as revised to accommodate the proposed alternate.

7. In addition to the material and equipment submittals, the Contractor shall provide shop drawings of the water service (fire and domestic) and the gas service complete with all appurtenances and indicate exact location by dimension to grading plan, submit for approval prior to installation.

1.10 UNINSPECTED WORK

Contractor shall not allow or cause any of his work to be covered up before it has been duly inspected, tested and approved by the Owner, Architect or any other authorized inspectors having legal jurisdiction over his work. Should he fail to observe the above, he shall uncover the work and, after it has been inspected, tested and approved, recover it at his own expense.

1.11 RECORD DRAWINGS (Refer to provisions of Section 23 00 00)

Contractor shall provide and keep up-to-date a complete "as-built" record set of blue-line prints which shall show every change from the original drawings and the exact "as-built" locations and sizes of the work provided under this Section of the specifications. This set shall include locations, dimensions, depth of buried piping, cleanouts, shut-off valves, sewer invert locations, plugged wyes, tees, etc. On completion of the work, the Contractor shall incorporate all as-built information on a set of reproducible tracings provided by the Architect and this set of reproducible shall be delivered to the Architect.

1.12 GUARANTEES

- A. Contractor shall guarantee the entire plumbing and piping systems unconditionally for a period of one (1) year after final acceptance. If, during this period, any materials, equipment, or any part of the systems fail to function properly, the Contractor shall make good the defects promptly and without any expense to the Owner.
- B. Contractor shall be responsible for all damage to any part of the premises caused by leaks in pipelines or equipment furnished and installed under this Section for a period of one (1) year after date of acceptance of his work.
- C. All equipment and fixtures shall carry manufacturer's warranty against defective parts or poor workmanship and shall not be less than one (1) year. See specific equipment specifications for extended warranty requirements.

1.13 PRODUCT HANDLING

Conform to provisions of Section 23 00 80 & 23 00 00.

PART 2 – PRODUCTS

2.01 PIPING SYSTEMS

- A. Materials: Refer to section 23 00 80.
- B. Insulation for Piping. Refer to Section 23 00 50.

2.02 FIXTURES AND DRAINS

A. General:

1. Fixtures specified shall be furnished and installed complete with trim and fittings. The manufacturer's name, item numbers, or trade names hereinafter given are used to indicate general design only and are not exclusive.
2. Items by other manufacturer's of similar design and of overall quality may be submitted for approval. Sizes, capabilities, dimensions and other characteristics designated are minimum requirements.
3. Cast iron plumbing fixtures shall be acid resistant enameled, and identified by casting the letters AR or the words acid resistant into the metal. Fixtures shall be white enameled inside and on back, rim and apron, with exposed unfinished surfaces painted white. Fixtures of the same general classifications shall be of the same make.
4. When a fixture piece of plumbing equipment, appliance or trim is not noted on the Drawings or not specified, the contractor shall furnish a unit complete with trim required for proper operation in compliance with standards set up by the District. If no such standards have been established, the Contractor shall furnish the unit as is usually furnished by the manufacturer when ordered complete.

B. Finished Brass:

1. Unless otherwise specified, finished brass of a similar type shall be of the same manufacturer throughout the building or buildings.
2. Finished and exposed brass equipment, except floor, shower and urinal drains shall be heavily of chromium plated and polished. Floor, shower and urinal drains, unless otherwise specified, shall be nickel bronze metal. Furnish and install drains in areas being modernized and/or receiving new flooring.

C. Traps and Tailpieces:

1. Fixture traps shall be brass, chromium plated and polished. Exceptions: (1) traps which are and integral part of the fixture, (2) traps concealed in floors, walls, cabinets or furring and (3) trap standards for service sinks and Industrial Shop Equipment. Tailpieces shall not be lighter than 17 gauge, brass, chromium plated and polished. Furnish and install chromium brass plated wall flanges with set screws and chromium plated and polished areas casing on discharge or each chrome plated trap.
2. Concealed traps and tailpieces may be rough brass, except as otherwise specified. Furnish and install chromium plated and polished brass casing on discharge side of each trap.

D. Fixture Supplies:

1. Supplies to flush valves, water closet tanks, lavatories and drinking fountains, and other fixtures, shall be equipped with chromium plated and polished screwed type angle

compression stops with square shank items and lock shields extending beyond the stem.
Exception: Supplies which rise vertically from the floor shall have straight type instead of angle stops.

2. Each supply or pipe which penetrates a finish surface and plumbing pipes passing through a countertop or part of a cabinet shall be equipped with a chromium plated brass flange.
Exception: Approved flanges furnished by the manufacturer of the flush valves as an assembly.
3. Water supplies of plumbing fixtures shall be protected against a back-siphonage in the event of a vacuum in the piping system.
4. Discharge outlets of supply faucets for lavatories and sink shall clear the top of the overflow rim at least 1".
5. Toilet and urinal flush valves shall be equipped with approved atmospheric vacuum breakers.

2.03 CLEANOUT ASSEMBLIES (Cleanout Plug Shall be line size)

- A. Wall cleanout: Iron body cleanout tee full line size and round nickel bronze or polished stainless steel access plate; plugs shall be brass, countersunk with tapped boss for screw. Refer to detail on mounting height.
- B. Floor Cleanout: Iron body with approved brass plug, top and adjustable sleeve, cut-off ferrule, polished scoriated brass nickel bronze secured cover (for finished floors inside buildings in covered areas, and in concrete sidewalks.) Refer to detail.
- C. Grade Cleanout: Secured cover, extra heavy duty, adjustable sleeve, cut-off ferrule, brass approved type plug, scoriated tractor type cover (areas outside of building or concrete paving). Cleanout is to be installed in reinforced concrete pad with chamfered edges. Refer to detail.

2.04 DRINKING FOUNTAINS

- A. Cooler/Bottle Filling Station:
Unit shall provide 8.0 GPH of 50°F water at 90°F ambient and 80°F inlet water. Bottle filling unit shall include an electronic sensor for no-touch activation with an automatic 30-second shut-off timer. Shall provide 1.1-1.5* GPM flow rate with laminar flow to minimize splashing. Shall include antimicrobial protected plastic components to prevent mold and mildew. Cooler unit shall have pushbar activation and water-efficient Stream-Saver bubbler. Shall include the Water Sentry Plus filter, certified to NSF/ANSI 42 and 53 for lead reduction, with visual monitor to indicate when replacement is necessary. Bottle Filling unit shall meet ADA guidelines for parallel approach. Cooler shall meet ADA guidelines for frontal or parallel approach. Unit shall be leadfree design which meets Safe Drinking Water Act and is certified to NSF/ANSI 61 and California AB1953. Unit shall be certified to UL399 and CAN/CSA 22.2 No. 120. Refer to wall mounted drinking fountain (rinking fountain
- B. For further information refer to plumbing schedule on drawings and specifications. Side by Side drinking fountains are to be installed with individual waste and vent piping, combination drainage of fixture is unacceptable. Carrier will fit in 4" wall only if individually waste and

vented. Floor mounted carrier with upper and lower mounting brackets are to be installed for all drinking fountains.

2.05 DIELECTRIC UNIONS

- A. Union-screwed (ground Joint). Acceptable manufacturers: Watts, Smith-Blair.
- B. Union Flanged. Acceptable manufacturers: Watts, Smith-Blair.

2.06 FLOOR DRAINS

- A. Cast iron body, inside caulked with seepage pan and flat, square 6" x 6" nickel bronze adjustable strainers not less than with maximum of 1/2" square holes or slots not larger than 1/4" x 1/4" for use in locations other than tile floors.

2.07 FLUSH VALVE

- A. Flush valves shall be of the rubber diaphragm quiet flush type. Diaphragm of nominal 3" diameter shall contain monel meter bypass and shall be rapidly reinforced with red brass. Valves shall be so arranged that the flush will remain constant and not require any adjustment or have any adjusting device. Flush valves for urinals shall deliver 1/2 to 1 gallon at each operation at any pressure from 5 to 100 lbs. with handle held in any position. Flush valve for water closet shall deliver three gallons at each operation.
- B. Silencing feature at the flush valve shall be in the valve proper and in the associated stop. Silencing feature shall allow flush valve to flush and close quietly without restricting the flow of water.
- C. Each flush valve shall be provided with a loose key, square shank, lock shield angle service stop connected to flush valve with a union connection and adjustable nipple. Screwdriver stops will be permitted when working parts contacting water are nonmetallic and a five (5) year warranty against corrosion, jamming or operational difficulties has been filed with the district. Stops at water closets shall be equipped with rubber seats bumpers.
- D. Provide 17 gauge pressed brass escutcheons both for wall and fixture. Escutcheons shall be solidly attached so as not to turn or rattle.
- E. Each flush valve shall be equipped with a vacuum breaker or having 1" opening to the atmosphere, which will not leak under any degree of back pressure which will not restrict the rate of flow more than 10% at 10 lbs pressure and will operate noiselessly.
- F. Tailpiece assembly shall not be lighter than 17 gauge and shall be part of the flush valve assembly.
- G. Exposed metal parts of the flush valve assembly to be heavily nickered and then chromium plated on a brass or copper base.

2.08 LAVATORIES

- A. Exposed trim shall be free from sharp edges or points. Fixture shall be furnished with other listed manufacturer specified trim. In lieu of solid supply pipe, polished chrome plated risers, ½" outside diameter with ferrule stop end and metal nose piece may be used. [Refer to drawings for schedule of lavatories.]

2.09 "P" TRAPS

Cast brass complete, chrome plated.

2.10 SINKS

Refer to Plumbing Schedule on drawings.

2.11 SERVICE SINKS

- A. Cast iron, for acid resistant enameled, 22"x18", with blank back, outlet trap standard and rough plated double faucet with top brace mounted above sink back, furnished with vacuum breaker and hose end.

2.12 SERVICE STOP VALVES

- A. Brass, ½" to 2", inclusive, with flat or square head No. 125 class.
- B. Black, iron body equipped with bronze plug and washer, ½" to 2" inclusive, with flat or square head, No. 125 class.
- C. Lubricated, 2-1/2" and larger, flanged type.
- D. Brass, ½" to 2" with lever handle.
- E. Concealed loglighter type, for boys' gymnasium drinking fountain (cuspidor strut-off)

2.13 SINK TRIM

Sinks specified herein shall be furnished with strainer and tailpiece unless otherwise noted. Supplies shall be ½" internal diameter.

2.14 URINALS

Vitreous china, wall hung, siphon jet action with flush valve. (For wheelchair accessible, student and adult use)

2.15 WATER CLOSETS

- A. General: Water closets shall be vitreous china with polyvinyl chloride bolt caps.
- B. Refer to Plumbing Schedule on Drawings.

2.16 DOMESTIC WATER HEATERS

- A. Storage type water heaters shall have five (5) year unconditional guarantee on the tank heater and it's working parts. The complete guarantee for each heater shall be delivered in the Operation and Maintenance Manual
- B. Heater shall be furnished complete with baked enameled jacket, double density insulation, heating device, energy saving thermostat, drain valve, and appurtenances necessary for satisfactory operation. The proper label of approval and manufacturer name, model number, size in gallons, and rated capacity shall be permanently secured to the jacket.
- C. Heater shall have a combination pressure temperature relief valve.
- D. Heaters gas and electric shall be certified by the ASME.
- E. Floor mounted heaters shall be on legs which are part of the heater. Each heater shall be securely bolted on the floor or strapped to the structure.
- F. Water heaters shall be Underwriters Laboratories tested, approved and listed. Heaters shall be furnished complete with baked enamel jacket, glass fiber insulation, heating element, double break acting snap thermostat, drain valve and all appurtenances required for operation. Install a gate valve and union on both the inlet and outlet sides of all heaters and combination pressure-temperature relief valve on the discharge side. Hot water piping when exposed in a finished room, shall be brass chromium plated pipe with brass chromium plated fittings, iron pipe size. Flexible water piping connectors shall not be used. Heater and the fixtures it serves if entirely exposed in a finished room pipe shall be brass chromium plated pipe with brass chromium plated fittings, iron pipe size. Flexible water piping connectors shall not be used.
- G. Water heaters shall be of sizes indicated on the drawings and shall have equipment necessary to make a complete and satisfactory piece of equipment.
- H. The combination pressure and temperature relief valve shall be installed on hot water line immediately above the heater with the sensing element located at the top of the water tank.
- I. Pilot lines, gas valves, relays and their wiring shall be located outside the boiler jacket to protect them from ambient temperature within. The flame safeguard relay shall be mounted on a control panel attached to the wall at the location indicated as directed. Other controls and manual operators shall be so located as to be accessible when the boiler is in the installed position.
- J. Wiring of the water pump control circuit and the line voltage supply to the control panel is a part of the electrical work. Other wiring in connection with the boilers is a part of the electrical work. Other wiring in connection with the boilers is a part of the work of this section. Wiring between the boiler and the wall mounted control panel shall be installed 7'-0" or more above floor level.
- K. Gas fired, storage type, size as shown on drawings, with approved draft diverter and energy cut-off devices. Connection to gas supply shall be made with the Underwriters Laboratories listed

corrugated flexible brass appliance connector (except 100,000 BTU and over connection shall be solid pipe.) Heater shall be seismically secure to floor.

2.17 WATER HAMMER ARRESTORS

A. Size as follows:

1. Lavatory Header, Wash Sink, Wash Fountain, Kitchen sink and Service sinks:
 - a. (3/4")
2. Urinal Headers:
 - a. (1")
3. Water Closets Headers:
 - a. (1")

2.18 DRINKING FOUNTAIN FILTER/STRAINER

Strainer shall be 60 micron, in-line bowl type strainer with positive molder rubber seal or fine mesh screen to provide protection from debris and contaminants. Strainer may be installed in-line using supplied 3/8" tubing connectors.

2.19 FIXTURE CONNECTION

A. Branches to individual fixture shall be of the following sizes unless larger sizes are indicated on drawings:

<u>Fixture</u>	<u>Copper Cold</u>	<u>Copper Hot</u>	<u>Trap and Connections</u>	<u>Soil or Waste</u>	<u>Vent</u>
<u>Water Closets:</u>					
Flush Valve	1 1/4"	-----	4"	4"	2"
Tank Type	1/2"	-----	4"	4"	2"
Lavatories:	1/2"	1/2"	2"	2"	1 1/2"
<u>Sinks:</u>					
Service	3/4"	3/4"	3"	3"	1 1/2"
Kitchen	1/2"	1/2"	2"	2"	1 1/2"
Classroom	1/2"	1/2"	2"	2"	1 1/2"
Wash	1/2"	1/2"	2"	2"	1 1/2"
<u>Drinking Fountains:</u>					
Multiple	1/2"	1/2"	2"	2"	1 1/2"
Single	1/2"	1/2"	2"	2"	1 1/2"
<u>Shower:</u>					
Individual	1/2"	1/2"	2"	2"	1 1/2"
<u>Fixture</u>	<u>Water Supply</u>	<u>Pipe</u>	<u>Flush Connections</u>	<u>Trap and Horizontal</u>	<u>Soil/ Vent</u>
<u>Urinal, Wall Hung:</u>					
Flush valve	3/4"	-----	2"	2"	1 1/2"
Flush valve (Accessible)	1"	-----	2"	2"	1 1/2"

Sillcocks: $\frac{3}{4}$ " minimum

- B. Hose racks shall have 2" supply lines. Reduce to 1 $\frac{1}{2}$ " at rack valve.
- C. Water header serving water closets shall be copper water tube, with the following size throughout length:
 - 1. 1 $\frac{1}{4}$ " for 2 to 3 flush valves.
 - 2. 1 $\frac{1}{2}$ " for 2 to 3 flush valves.
 - 3. 2" for 4 to 5 flush valves
 - 4. 2 $\frac{1}{2}$ " for 6 to 8 flush valves.
- D. Water header serving urinals shall be of the following size throughout length:
 - 1. 1" for 1 or 2 flush valves
 - 2. 1 $\frac{1}{4}$ " for 3 flush valves.
 - 3. 1 $\frac{1}{2}$ " for 4 to 8 flush valves.
- E. Water header serving showers shall be listed above for urinals.
- F. Water header serving lavatories shall be of the following size throughout length.
 - 1. $\frac{1}{2}$ " for 2 lavatories.
 - 2. $\frac{3}{4}$ " for 3 and 4 lavatories.
 - 3. 1" for 5 and 6 lavatories.

2.20 HEIGHT OF FIXTURES

- A. Unless otherwise indicated or specified, fixture heights shall be as follows:

<u>Fixture</u>	Adult		
Standard Toilets	15"		
Accessible Toilets	17" – 19"		
Grab Bars	33"		
Lavatories,			
Maximum top height	34" max.		
Accessible Lavatories,			
Knee clearance	29" min.		
Drinking Fountain,			
Bubbler height	42"		
Accessible drinking			
Fountain, knee			
Clearance	36" max.		
Urinals	24"	24"	18"
Accessible Urinal,			
Lip height	17" max.		

- B. Refer to drawings for fixture locations.

2.21 HYDRAULIC SHOCK ABSORBER

Zurn Z1700 Shoktrol Water Hammer Arrestors are regularly furnished in all stainless steel construction. Pipe threads are accurately machined to assure tight connection. 3/4" male I.P.S. inlet is standard for the 100 and 200 size units, while 1" male I.P.S. inlet is standard for sizes 300 thru 600. Size per pipe size.

2.22 MOP SINK BASINS

- A. Terrazzo composed basin, compressive strength of 3000 PSI, all parts ground smooth, drain is cast brass with stainless steel strainer integral cast in basin, 24"x24"x12", stainless steel cap and wall plats, outlet trap, chrome plated all brass double faucet with top brace mounted above sink back, furnished with vacuum breaker, hose and hose clamp. Caulk around entire fixture. Hose clamp is to be mounted at faucet height.

PART 3 – EXECUTION

3.01 EXAMINATION

- A. Examine the areas and conditions under which work of this Section will be performed. Correct conditions detrimental to the proper and timely completion of the work. Do not proceed until unsatisfactory conditions have been corrected.
- B. Check each piece of equipment in the system for defects verifying that parts are properly furnished and installed.

3.02 INSTALLATION

- A. Unless otherwise specified, plumbing fixtures, equipment and appliances which require connections to plumbing line shall be connected. This shall include fixtures specified or indicated as furnished by other, furnished by district, or specified in another section.
- B. Install all equipment per manufacturer's installation instructions and governing codes; it is the Contractors' responsibility to obtain these instructions and codes.
- C. Avoid interference with the work of other trades. Do not make changes from drawings without acceptance of the Architect or Engineer.
- D. Any equipment requiring electrical service is to be coordinated with Electrical Contractor. Contractor is to supply Electrical Contractor with manufacturers wiring diagrams and requirements.
- E. Fixtures equipment and appliances which are not being supplied by this section but require connections by this division will be indicated by B.T.C. (branch to connection) and D.F.A. (drop from above).

3.03 FIXTURES AND EQUIPMENT

- A. Unless otherwise indicated, fixtures shall be hung, supported or set with manufacturer's recommended floor mount or wall mounted carrier with bolts of sufficient length to securely fasten the fixture to the backing, wall or closet ring.
- B. Carriers set in concrete or masonry walls shall be coordinated with mason contractor.
- C. Drinking fountains shall be hung with carrier and auxiliary plate as specified. Bottom of drinking fountain is not to be loose from wall.
- D. Carrier for hanging of plumbing fixtures and equipment shall be installed in the supporting wall at the time rough piping is installed. Wood supports between studs will not be acceptable.
- E. Rough-in for fixtures, equipment, and appliances noted on the drawings shall include fixtures, equipment and appliances indicated as NIC (Not In Contract), Furnished by Others, Furnished by District, or Future. When connections to equipment from capped or plugged lines are required, caps or plugs shall be removed at the time equipment is set and the stops or valves installed and connections made as specified.
- F. Piping shall be stubbed out to the exact location of the fixtures and stubs shall be symmetrical with the fixtures. Hot and cold water supplies for center set faucets shall be set on 8" centers, unless otherwise specified or directed.
- G. Hot water and tempered water return line are to be routed down wall and connected to lowest point of supply line.

3.04 CLEANOUTS

- A. Cleanouts shall be installed at locations stated in the current edition of the City Plumbing code and, in addition, at the following locations:
 - a. All locations above the first floor, as stated.
 - b. Above the faucets of each sink.
 - c. For each urinal.
 - d. Above the overflow level of the pot sinks.
 - e. Not to exceed 100 foot intervals in sewer and waste lines exterior of the building.
 - f. At the property lines.
 - g. Wherever else shown on the drawings.
- B. Cleanout shall be extended to grade as follows:
 - 1. Not to exceed 100 foot intervals in straight runs of pipe outside the buildings.
 - 2. At changes of direction greater than 22 ½ degrees.
 - 3. At the property lines.
 - 4. Where cleanouts occur under concrete.
 - 5. Where marked for future connection. Cleanouts in the building shall be extended to floor level, or above floor level in walls or furring when the cleanouts are not accessible or where the clearance is less than 18".
- C. Cleanouts in finished areas in the building shall be concealed with stainless steel cover plate.

- D. Cleanouts in floors of covered areas and those that extend to grade in concrete areas shall be the floor level type with extensions body brass plugs and detachable nickel bronze aluminum alloy scoriated.
- E. Concealed cleanouts in vertical lines shall be service weight soil cleanout tees with brass plugs and round cover plates unless otherwise specified or indicated. A snug fitting sleeve of galvanized sheet metal shall be placed around the hub of the tee and shall extend to flush with finished soil, or the cleanout shall be extended to the finished wall.
- F. Cleanouts extended from below the floor to a wall or furring or on horizontal lines above floor which terminate at a wall or furring shall be iron body type with brass plugs and round cover plates. Wall cleanouts are to be no lower than the highest p-trap in the same or nearest room.
- G. Cover plates over cleanouts in painted wall shall be steel, bonderized and prime coated. Cover plates over cleanouts in tile walls shall be chromium plated brass or nickel bronze. Plates shall be attached to cleanout plugs with 5/16", 1/8", or 1/4" 20 stainless steel vandal proof type screws. Plates shall be 1" larger in diameter than fitting opening.
- H. Cleanouts at the bases of downspouts shall be tapped soiled tees with brass plugs as herein after specified, full size of the line.
- I. Cleanouts extended to grade in exterior sewer line other than floors or concrete areas shall be a cleanout assembly with a secured top, extra heavy duty, adjustable sleeve cut off ferrule, countersunk threaded brass plug scoriated tractor type cover.
- J. Other cleanouts shall be iron body type.
- K. Cleanout extensions shall be no-hub cast iron soil pipe. Exterior cleanouts, those in concrete excepted, shall terminate in a 14" x 6" thick concrete block with the cleanout assembly and the top of the block flush with the finish grade.
- L. Fittings in lines used as cleanouts shall be approved soil fittings including no-hub pipe. Tees and crosses invent headers excepted.
- M. Pipe joint compound shall not be use on cleanout plug. After the lines are tested and approved, each cleanout plug shall be removed, greased and replaced.

3.05 EXCAVATION, TRENCHING, AND BACKFILLING

Perform trenching, excavation, and backfilling required for the work of this Section as specified herein.

3.06 SERVICE CONNECTIONS

- A. Determine exact location of required water, drain, and sewer connections and make proper connections.
- B. Potable waterlines shall be purged completely prior to use before connecting to the source(s) of water for the project. The Contractor and the District Plumbing Inspector shall visually ascertain the quality of the water supply. The connections shall not be made unless the

supplied water quality is agreeable to both parties. Disagreement shall be referred to the Architect and for resolution before proceeding.

3.07 WATER HAMMER ARRESTORS

- A. Install water hammer arrestors indicated on the drawings and in the following locations (only non-ferrous arrestors may be used in copper water system):
 - 1. Water lines to service sinks, kitchen sinks, wash fountains, clothes, washers, laboratories with medical type faucets and on wash sinks having three or more stations, as close to the fixture as possible.
 - 2. Between the last two fixtures when three or more fixtures, other than those listed in Paragraph 1 above, are served by a common header.
- B. When possible, arrestor shall be installed in the wall or furring. When arrestor is installed in wall or furring, furnish an access plate large enough to permit removal of the arrestor. The access plate shall be a minimum of 2" larger in each direction that the arrestor. Where not specifically offered in the contract documents, installation shall be in accordance with the Plumbing and Drainage Institute Standard PDI-WH201.
- C. Each fixture water line shall be provided with a dampening device. When such service is not provided by water hammer arrestors, provide an air chamber at each fixture supply.

3.08 GAS SERVICE

- A. Service Above the Ground:

Pipe shall be steel, hammered free of dirt and scale, and blown out with oil-free air or nitrogen to a clean dry condition. Piping shall not run in or through a ventilation duct or plenum.
- B. Service Below the Ground:

Pipe shall be polyethylene pipe free of dirt, and blown out with oil free air or nitrogen to clean dry condition. Polyethylene piping is to be local utility company accepted and is to have butt-fused connections. Socket fusion is not acceptable unless required by local code.
- C. All gas piping is to be butt-welded until final connection to equipment. Piping is to be labeled inside of building with yellow label stating flow and "GAS".
- D. All exterior gas pipes are to be primed and painted with 1 coat of primer and 2 coats UV resistant enamel.
- E. Piping shall not run in or through a ventilation duct or plenum.

3.09 CLEANING OF PLUMBING PIPING SYSTEMS AND FIXTURES

- A. Prior to acceptance, plumbing lines and fixtures shall be flushed thoroughly to remove dirt and foreign materials until the water runs clear and no foreign substance or odor is present. Strainers and screens on faucets shall be removed during this cleaning operation.

- B. After satisfactory cleaning and strainer and screen replacements has been witness by the District's Plumbing Inspector, a certificate of compliance shall be furnished to the District by the Contractor and countersigned by the District's Plumbing Inspector. Until the certification of compliance has been officially received by the District, the Contractor shall post and maintain signs stating: Caution – Water at this construction project has not yet been certified for human consumption.
- C. Signs shall have letters at least ½" in height, and shall be conspicuously posted at each entrance to the construction area and at the entrance to the inspector's facilities. Signs shall be paneled, black and yellow, in conformance with OSHA Section 1910. 1455.

3.10 VALVES ON PLUMBING SYSTEM

- A. Furnish and install gate, globe, angle and check valves on all plumbing work at the following locations whether indicated or not:
 - 1. A ball valve to control water lines to each group of fixtures. A group of fixtures shall be considered to be three or more fixtures which are in the same room. These valves shall be accessible from the room in which the fixtures are installed. These valves shall control the fixtures in the room in which they are installed.
 - 2. A ball valve on each building branch line, which serves two or more fixtures when these fixtures do not have a group control valve as specified in the paragraph immediately above.
 - 3. A partition stop on the supply to a drinking fountain and on each concealed fixture supply. The partition stop shall be located below the fixture.
 - 4. A loose key angle stop on each exposed fixture supply, unless otherwise specified, and for each flush valve.
 - 5. A ball valve at each location where a water line is connected to a piece of equipment other than mentioned above.
 - 6. A spring loaded check valve on each hot water return line where it connects to a hot water storage tank or a water heater.
 - 7. Exposed stops on plumbing fixture supplies, exposed shower valves and the exposed part of the concealed valves or stops shall be chromium plated and polished, unless otherwise specified.
 - 8. Handles, hand wheels (including dishwasher fill valve handles) and operating nuts shall be steel, brass or cast iron and shall be removable. Unless specified to be loose key type, handles shall be securely fastened to their stems. On exposed outdoor valves, omit operating handles and provide operating nuts.
 - 9. Furnish a handle or key for each five, or fraction thereof, loose key valves, bibs or stops and deliver same to District Inspector.
 - 10. Valve extensions are to be installed on all ball valves.

3.11 VALVES, GAS SERVICE

- A. Gas stops shall be installed at the following locations where rerouting, capping and/or abandonment of gas service is indicated. Provide as required.
1. A gas service stop connected to the gas main or header at the master assembly.
 2. A gas service stop on each outlet, in addition to any gas stop furnished with equipment. Service to laboratory gas cock shall have a special precision check valve, located downstream from the gas stop servicing the room outlet at each laboratory cock. Unless otherwise specified, 1/8" bore shall be provided for each outlet cock. A plugged tee shall be located immediately downstream of the check valve.
 3. A gas service stop on each gas line serving two or more gas outlets in the same room.
 4. A gas stop on the inlet side of each gas pressure regulating valve. This may be the stop furnished with the equipment.
 5. Gas stops at no more than 1,000 foot intervals on each gas main.
 6. Gas solenoid valves to kitchens, science rooms and laundry equipment.
- B. Gas stops, 2 1/2" and larger, shall be semi-steel lubricated plug valves and shall be furnished with operating wrench, one for each valve. Gas stops, 1/2" to 2" inclusive, installed outside the building, in crawl spaces under a building, in tunnels, boiler rooms or equipment rooms shall be an iron stop with a brass plug. Other gas stops shall be brass for not less than 125 PSI steam pressure. Service stops in classrooms and other location accessible to students shall be of the square head or flat head type. Service stop for gas fired equipment in locations not accessible to students shall be supplied with handles.
- C. When a service stop adjacent to gas fired equipment is indicated on both the Plumbing and Mechanical drawings, the stop shall be furnished and installed as part of this Section.
- D. Dirt legs are to be installed on all interior gas fired equipment.
- E. Gas solenoid valves: Valve size is to be line size and valve is to be threaded. Acceptable manufacturers are ASCO (8040/8215), Granzow, and Alcon. Valves are to be normally close; meaning when there is no power to valve, valve is closed. Power requirements per plans. Tag for valve is to be labeled on what it is disconnecting from gas service. Valve is to be installed in a accessible location. Construction of valve: Aluminum or brass body; NBR seals, diaphragms, and discs; CA core guide; 305 stainless steel core tube; PTFE rider rings; 430F stainless steel core and plugnut; 302 stainless steel springs; and copper shading coil. SA, SA (gas), UL, FM, CE, and CSA certified

8040 Normally Closed Series:

- 1) Standard C22.2 No. 139 "Electrically Operated Valves," File 10381.
- 2) Automatic Gas Valves Z21.21 (6.5), File 112872.
- 3) Automatic Gas Safety Shutoff Valves C/I (3.9), File 112872.

8215 Series Normally Closed:

- 1) Standard C22.2 No. 139 "Electrically Operated Valves," File 10381.
- 2) Automatic Gas Valves Z21.21 (6.5), File 112872.

3.12 ELECTROLYSIS PREVENTION

- A. Insulating (dielectric) approved couplings (Smith-Blair type for gas service), unions or flanges shall be furnished and installed at locations described herein. Dielectric insulators shall be installed the two pipes being connected, and shall be installed in the following locations:
 1. In gas service connections at locations where gas pipe enters or leaves the ground at structures. In piping 2" and larger, install companion flanges as specified above. When the underground gas line passes through a concrete slab, footing or foundation as it enters the structure, install the dielectric insulator immediately above the concrete.
 2. In gas service connection in the ground at the point where new metallic lines connect to existing metallic lines.
- B. Where special applications shown in drawings require an insulation flange or coupling to be placed on a condensate line, or steam line, the flange or coupling insulation shall be of a high temperature type, suitable for continuous operation at temperatures up to 220 degrees Fahrenheit for condensate and 400 degrees Fahrenheit for steam. Where steel or cast iron in the ground connects to copper or brass piping above ground, the transition from steel to cast iron pipe to the copper or brass pipe shall be made above ground in an accessible location. Underground dielectric connections shall be in accessible approved yard box with pipe risers, as necessary, to located 3'-0" below grade.
- C. Above ground dielectric connections shall be exposed. If finished rooms, shall be located in accessible access boxes.
- D. Dielectric unions are to be installed on all water heaters and any equipment with non-same material connections.

3.13 OBSERVATION OF INSTALLED WORK

- A. Contractor is to call engineer one business day in advanced before covering under ground work.
- B. Contractor is to call engineer one business day in advanced before covering all piping in ceiling and in walls.
- C. Field observation report will be filled out on status of work and problems to architect. Work is not to be covered until engineer gives his/hers acceptance. Engineer will not revisit site until WSA receives from the Architect, the contractor's comments stating that they made the changes or the reason why they could not.
- D. All close out documents, i.e. O&M manuals, Plumbing As-Built drawings, 11x17 colored laminated drawing show shut-off valves, completed field report.

END SECTION

SECTION 22 04 50

PLUMBING FIXTURES

PART 1 - GENERAL

1.01 WORK INCLUDED:

(All devices associated with above items are to be submitted, refer to plumbing schedules and section 23 00 00, 23 00 50, 23 00 80, 23 01 00, & 22 04 00.)

- A. Water Closets (S).
- B. Urinals (S).
- C. Lavatories (S).
- D. Sinks (S).
- E. Electric Drinking Fountains (S).
- F. Wall Hydrants (S).
- G. Hose Bibs (S).
- H. Roof Drain (S).
- I. Floor Cleanouts (S).
- J. Wall Cleanouts (S).
- K. Grade Cleanouts (S).
- L. Floor Drain (S).
- M. Service Sink/Mop Sinks (S).
- N. Water Heaters (S).
- O. Yard Hydrants (S).
- P. Utility Trench (S).
- Q. Stops for Science Sinks ST-1 (S).
- R. Drains for Science Sinks D-1 & 2 (S).
- S. Dilution Tank (S).

- T. Backflow Preventor (S).
- U. Floor Sinks (S).
- V. Lavatory Stations (S).
- W. Circulating Pumps (S).
- X. Vent Thru Roof Caps (S).
- Y. Tempered Water Mixing Valves Standard/Emergency (S).
- Z. In-line Water Filters (S).
- AA. Ice Maker Box (S).
- BB. Emergency Science Shut-off System (S).
- CC. Garbage Disposal (S).
- DD. Sump Pump (S).
- EE. Pressure Reducer (S).
- FF. Acid Waste & Vent Pipe (S).
- GG. All Isolation Shut-Off Valves (S).
- HH. Material of Pipe (S).
- II. Warning Tape and Tracer Wire (S).
- JJ. Pipe Insulation (S).
- KK. Protective Covers for Insulated Fittings (S).
- LL. De-ionization Tanks (S).
- MM. Piping Saddles (S).
- NN. Pipe Identification Method (S).
- OO. Water Hammer Arrestors (S).
- PP. Expansion Tanks (S).

- QQ. Check Valves (S).
- RR. Unions Standard/Dielectric (S).
- SS. Washer Boxes (S).
- TT. Grease Interceptor (S).
- UU. Solids Interceptor (S).
- VV. Dryer Box (S).
- WW. Emergency Eye Wash and Shower (S).
- XX. Emergency Eye Wash (S).
- YY. Oil Interceptor (S).
- ZZ. Down Spout (S).
- AAA. Showers (S).
- BBB. Trench Drains (S).

1.02 REFERENCE STANDARDS:

- A. National Bureau of Standards, CS 20-49.
- B. National Plumbing Code.
- C. American National Standard, ANSI.

1.03 SUBMITTALS:

- A. Submit in accordance with Section 23 00 00.
- B. Refer to Section 23 00 00, paragraph 1.02 for Method of Preparation.

1.04 PLUMBING FIXTURES:

- A. This Contractor shall furnish and install complete all plumbing fixtures shown on the plans and/or specified herein. Catalog numbers and fixture names are noted on plumbing schedule sheets, refer to plans for designations. All supplies and wastes shall have set screw or lock type escutcheons at the point the pipe passes through the wall or ceiling. All exposed metal parts shall be chrome plated brass unless otherwise specified. All plumbing brass is to be stamped with manufactures and gauge of metal. All fixtures, i.e. faucets, all sinks, water closets, urinals, showers and shower valves, valves and unions, backflow preventors, flush valves, carriers, all

drains, all hydrants/bibbs, water heaters, expansion tanks, lavatories, all drinking fountains, roof drains, all cleanouts, piping, etc. shall have an identifying label permanently affixed to the system indicating that factory inspections have been performed per the current International Plumbing Code section 107.1.2.2.

- B. Provide new fixtures free from flaws and blemishes with finished surfaces clear, smooth and bright.
- C. Mounting studs and nuts shall be chrome plated or concealed with china bolt caps. All fixtures shall be provided with an exposed chrome plated shut-off valve.
- D. Compliance with Codes: It is the intent that all plumbing fixtures, fittings, devices and the installation of same shall meet the requirements of the International Plumbing Code, Local or Area Plumbing Code, whichever may be more stringent or have jurisdiction. This shall apply whether or not indicated on the drawings or contained in these specifications.
- E. The Contractor is required to coordinate all final connections to equipment being supplied by Contractor and by others before installing any piping. If there is a discrepancy Contractor is to contact Engineer and Architect immediately before proceeding.

END OF SECTION

SECTION 23 00 00 GENERAL

MECHANICAL

PART 1

1.01 GENERAL:

The General Conditions of specifications and all preceding sections bound herewith are included in and made a part of these sections.

1.02 NOTICE TO BIDDERS

- A. All parties bidding on this work shall be sure that they understand all requirements of the plans, details, these writings, and local conditions thoroughly, for each will be bound by all things appearing therein, should the contract be awarded him, and in case of any obscurity or uncertainty, he shall apply to the engineer in writing for a correct interpretation before submitting his bid.
- B. The Contractor is required to coordinate all final connections to equipment being supplied by Contractor and by others before installing any piping. If there is a discrepancy Contractor is to contact Engineer and Architect immediately before proceeding.

1.03 MATERIAL SUBMITTALS:

- A. Unless deemed otherwise by the engineer, no single items will receive consideration. Only bound complete submittals will receive consideration. This submittal shall be made within 30 days after awarding of the contract.
- B. Submit six (6) copies, bound in six (6) three-ring red binders for HVAC, six (6) copies, bound in six (6) three-ring blue binders for Plumbing to the Architect for acceptance. Submittals to have a table of contents and index tabs for easy reference and usability. Submittals should be **clearly marked** in red to show any changes from the original specifications. In case of re-submittal, the contractor shall re-submit in quadruplicate showing required corrections and shall continue to re-submit until acceptance is obtained.
- C. All equipment specified herein and noted (S) shall be submitted.
- D. Acceptance, corrections or comments made on submittals and/or shop drawings on sepiareproducible during review do not relieve the contractor/ supplier from compliance with the specifications. This check is only for review of general conformity with the design concept of the project and general compliance with the information given in the contract documents. The subcontractor or supplier is responsible for confirming and correlating all quantities and dimensions; selecting fabrication processes and techniques of construction and coordinating his work with that of all other trades (unless specifically stated otherwise in the contract documents).

1.04 COOPERATION:

- A. This Contractor shall promptly report to the General Contractor any conditions which might prevent prompt and proper installation of work, or make it unsuitable to connect with or receive work of others. Failure to so report shall constitute acceptance of the work as being fit and proper for completion of this work.
- B. In general, the following priorities shall prevail:
 - 1. Ductwork
 - 2. Building Drainage
 - 3. Piping – domestic water, fire protection, sanitary drain & vent, roof and overflow drain, gas, HVAC piping
 - 4. Conduit and boxes

1.05 MATERIAL OTHER THAN THOSE SPECIFIED:

- A. The base bid and alternates, if any, shall include all items as they are specified or detailed in the drawings or accepted equals.
- B. Where several manufacturers are listed for one use, the contractor may select any of those specified.
- C. A request for consideration of items other than those specified, which are to meet or exceed the plans and specifications, may be made to the engineer in writing until ten (10) days before the bid date. An addendum will then be issued listing any materials which may have been accepted. There will be no subsequent substitutions.
- D. In those cases where an equal product is allowed, the decision as to quality rests with the engineer.

1.06 CLEANING:

- A. Upon completion of work, piping systems shall be thoroughly blown down and cleaned out with water wasted to sewer. After thirty (30) days normal operation, contractor shall clean all traps and strainers.
- B. All ductwork shall be cleaned (by hand) prior to installation of grilles, diffusers or adjustable turning vanes. After installation of all devices and connection to fan, operate system with all outlets wide open blowing out all dust or refuse.

1.07 EXCAVATION AND BACKFILLING FOR PIPING:

- A. The Contractor shall do all excavating, backfilling, shoring, bailing and pumping for the installation of his work. Sewer lines shall not be used for draining trenches and the end of all pipe and conduit shall be kept sealed and lines left clean and unobstructed during construction. Only material suitable for backfilling shall be piled a sufficient distance from banks of trenches to avoid overloading. Unsuitable backfill material shall be

removed as directed by engineer. Perform grading necessary to prevent surface water from flowing into trenches or other excavations. Sheathing and shoring shall be done as necessary for protection of work and safety of personnel. Unless otherwise indicated, excavation shall be by open cut except that for short sections. A trench may be tunneled if in the opinion of the architect, the pipe or duct can be properly installed and backfill can be properly tamped. Three feet minimum cover shall be used for service water lines, sanitary and storm sewers. Two feet minimum cover shall be used for gas. All pipe shall be laid on a four inch bed of sand.

- B. After testing and acceptance of the pipe lines, trenches shall be backfilled to a depth of 6 inches over the top of pipe with washed river sand then to full depth of excavation with materials containing not rock, wood or other organic materials. Materials shall be placed in layers not over 6" thick and each layer thoroughly compacted so no later settlement will take place. Backfill shall be brought up to level of ground surface and surface graded to satisfaction of Engineer. When under buildings, structures, walks and concrete slabs the entire ditch is to be filled with sand to grade.
- C. The Contractor shall install six inches below grade and directly above all domestic water, irrigation supply water, fire protection, sanitary sewer, storm sewer, electrical conduits and natural gas lines with an mylar foil back warning tape and #12 tracer wire on pipe. Tape shall be aluminum foil encased in two layers of inert plastic film enabling the tape to be inductively located. Terra Tape "D" Warning Tapes are acceptable. Tape shall bear a continuous imprinted message repeated every 16 to 36 inches warning of the installation buried below. The message shall read "CAUTION" and then name the utility buried below. Example: "CAUTION (WATER LINE, GAS LINE, SEWER LINE, STORM SEWER LINE, ETC) BURIED BELOW". Installation instructions for the tape shall be printed with each message along the entire length. The tape shall be as that manufactured by Reef Industries, Inc., Houston, Texas (Terra Tape) or an accepted equal. Tape shall have metallic content and shall respond to metal detectors. **Do not exclude this.** It will be required to verify the installation of this tape.
- D. Protection of Existing Utilities - Existing utility lines uncovered during excavation operations shall be protected from damage during excavation and backfilling, or if damaged shall be repaired by contractor.

1.08 START-UP AND SERVICE:

- A. Place all equipment and systems in trial operation and adjust all components for proper operation and balance.
- B. On date of final inspection, provide services of qualified personnel to operate equipment. Remove and replace access panels, make equipment adjustments and generally assist the Engineer inspector in the complete examination of the work.
- C. Free service for seasonal start-up and adjusting of heating and cooling equipment shall extend through the next seasonal start-up following acceptance by the Owner. If system is operating on "summer cycle" at acceptance, the Contractor shall provide winter start-up service and free service for adjustments.

1.09 OPERATING INSTRUCTIONS:

- A. Provide operating folio, in duplicate, containing the following:
 - 1. Brief typewritten statement of start-up and shut-down sequence for each item of equipment and each system. Statement should refer to valves by both name and assigned name.
 - 2. Typewritten or printed installation, operation and maintenance instructions for each item of equipment. This shall include points of lubrication, recommended lubrication frequency, type of lubricant, normal adjustment procedures and trouble shooting procedures. This section shall further include name and model number of each item of equipment, the source of repair parts and services with telephone numbers and manufacturers' repair lists, and operating characteristic curves for each pump and rated equipment.
 - 3. Folio shall be bound and submitted to Architect for acceptance and transmission to Owner.
- B. All valves, etc. shall be tagged with brass tags and they shall be identified as in the above instructions.
- C. One copy of shop drawings covering the control diagram and sequencing "As Built" shall be framed behind glass and mounted where indicated in the equipment room.

1.10 AS-BUILT DRAWINGS:

- A. Deliver to architect upon completion of work two (2) complete sets of contract drawings (white prints) marked up to show all deviations from indicated installations. Markings shall include:
 - 1. Changes in routings of concealed piping.
 - 2. Changes in concealed duct sizes and arrangements.
 - 3. Other changes to concealed work which affect future maintenance and repair operations.

1.11 GUARANTEE:

- A. See General and Supplemental Conditions for guarantees required.
- B. The Contractor shall guarantee all work, materials, and equipment under these specifications for a period of two (2) years from the date of formal acceptance. Within the guarantee period, all defective equipment of installation shall be made operative to the satisfaction of the Owner without additional cost to the Owner.
- C. No equipment, supplies or device shall be installed in a manner or application that is not recommended by the manufacturer. Contractor shall read the installation instructions and

install per instructions. If conditions exist where the installation instructions are contrary to the contract documents then the contractor shall notify the architect/engineer before ordering the equipment.

1.12 SITE VISITATION:

This Contractor shall visit the site before submitting a proposal on this work, and shall thoroughly familiarize himself with existing conditions. Failure on his part to do this will not be cause for extras after the contract is signed, by reason of unforeseen conditions.

1.13 SINGULAR NUMBER

Where any device or part of equipment is herein referred to in the singular number (such as "the pump"), such reference shall be deemed to apply to as many such devices as are required to complete the installation as shown on the drawings.

1.14 DIMENSION DRAWINGS:

After the mechanical submittal has been favorably considered, the Mechanical Contractor shall submit for review and correction, if required, one sepia and two prints showing all equipment located in the equipment room and the location of all floor drains serving the equipment. All major equipment shall be drawn to scale. The location of floor drains serving the equipment shall be dimensioned from columns, partitions, or other permanent parts of the building, two dimensions 90 degrees apart. This tracing shall be revised to include all changes required by the Architect.

1.15 EQUIPMENT LOCATIONS:

When the location of piping or equipment is governed by architectural features, this Contractor shall establish their location by referring to the dimensions shown on the architectural drawings. He shall not scale the drawings for exact dimensions.

1.16 FOUNDATIONS, BASES AND SUPPORTS:

This Contractor will be required to furnish all special foundations, bases, and supports required for the proper installation and operation of all equipment to be furnished under this contract. All equipment with moving parts shall be provided with isolation units and/or special bases to prevent transmittal of noise and vibration to the building structure.

1.17 MOTOR AND WIRING (S):

A. Motors shall be constructed in accordance with NEMA Standards and shall meet electrical requirements of the AIMEE. Motors shall have suitable starting and running characteristics to drive the loads to which they are connected and shall be applied to operate at not more than 100% of their rating. All motors 1/2 H.P. and larger shall be equipped with greasable type ball bearings. Motors shall be wound for 60-cycle service, and furnished with voltage as specified with equipment. All motors 1/2 H.P. and larger shall be rated high efficiency type; a minimum of 80% efficiency for 1-1/2 H.P. and less,

a minimum of 85% up to 10 H.P. and a minimum of 90% efficiency for those motors over 10 H.P.

- B. Packaged or factory-wired unit equipment shall be wired in full accordance with the National Electrical Code, and shall bear the label of the Underwriters' Laboratories, Inc.
- C. All motors for mechanical equipment hereinafter specified shall be furnished by the Mechanical Contractor. All starting equipment for the above mentioned motors shall be furnished by the Electrical Contractor with the exception of the starters furnished integrally with self-contained equipment and hereinafter specified, which will be furnished by the Mechanical Contractor.
- D. Unless otherwise specified or noted, all starters for motors 40 H.P. and under shall be of the across-the-line type and starters for motors over 40 H.P. shall be of the increment type.
- E. With the exception of starters furnished integrally with self-contained equipment, all starters and starting switches shall include an embossed plate identifying the equipment they serve.
- F. Where motor sizes are increased above those shown on the drawings due to variation in manufacturer's equipment, the Electrical Contractor will ascertain the requirements and make due allowances for the increased service thereto. Any additional cost in the electrical work caused by the variations in manufacturer's equipment will be the responsibility of the Contractor furnishing that equipment.

1.18 PAINTING:

All items of mechanical work under this contract shall be painted as follows, by the General Contractor:

- A. EXPOSED PIPING: As called for in the Division titled PAINTING. All such piping shall be painted.
- B. EXTERIOR METAL WORK: (Including all items of mechanical work that are not factory-finished.) One coat of accepted primer (omit on items that are factory-primed) and two coats of outside oil base paint.
- C. INTERIOR EXPOSED METAL WORK: (Including all items of mechanical work that are not factory-finished.) One coat of accepted primer (omit on items that are factory-primed) and two coats of alkyd-resin enamel to match adjoining work.

1.19 CUTTING, PATCHING, ETC.:

- A. Cutting, patching, hangers, etc., in connection with the installation of the work shall be accomplished by this Contractor, including cutting and patching of concrete, brick, paving, curbs, etc.

- B. Cutting, fitting, repairing, and finishing of carpentry, metal, plaster, concrete, etc., which is required for the work installed under this contract, shall be done at this Contractor's expense. Cutting through slabs already poured shall be done by core drilling only; no chipping, hammering, or jack hammer work will be permitted.
- C. This Contractor shall furnish and set all pipe sleeves required for the passage of piping through masonry and concrete, and all sleeves shall be set as the masonry and concrete work progresses.
- D. For piping passing through building floors, walls and partition, sleeves shall be of standard weight black steel pipe, and flush with the finished wall or partition lines. Pipe sleeves through floors shall extend 1/2" above the finished floor.

1.20 OPERATION AND MAINTENANCE INSTRUCTIONS:

- A. The Mechanical Contractor shall furnish (4) bound sets of Operating and Maintenance Instructions covering all equipment furnished under these specifications, as indicated with an O & M at the end of the paragraph title. The Owner shall receive two (2) sets, and the Architect and Mechanical Engineer one (1) set each. These instructions shall be assembled in an indexed loose leaf, 3-ring binder, as described in the paragraph titled SUBMITTALS. These manuals must have been delivered to the Architect and Engineer before mechanical installation is considered 75% complete.

1.21 VIBRATION:

The Contractor shall take those precautions he deems advisable, in addition to those set out in the plans and specifications, for the elimination of noise and vibration. The Contractor will be held strictly accountable for the noises and vibration transmitted to the occupied spaces of the building. If objectionable noise or vibration is present after the job is completed, the Contractor shall take all necessary steps for their elimination without any additional cost to the Owner. The means of eliminating noise and vibration shall, in general, be that recommended by the manufacturer of the equipment which is furnished for this job.

1.22 BELT DRIVES

All belt drives shall be of the multiple "V" type, Dayton or Gates. Provide variable pitch motor sheaves on all fan drives. Provide standard slide rails, or other means of belt adjustments, for each motor with a belt drive.

1.23 BELT AND COUPLING GUARDS:

Provide removable steel guards over all exposed belt drives and couplings. Guards shall conform to applicable state and local safety requirements.

1.24 EXISTING CONDITIONS:

The existing pipe, conduit ductwork, etc., have been referenced to original plans and on the job observations. If during construction different conditions are found, the Contractor shall so notify

the Architect or Engineer and on the job corrections shall be made. Note the contractor shall verify that the water pressure at the site is sufficient to operate that flush valves specified before ordering the valves and water closets. All flow lines of existing drainage lines shall be verified before beginning excavation for new piping. Verify all site grades before beginning excavation to assure proper covering of new piping.

PART 2 – PRODUCTS

2.01 SCOPE:

Furnish all labor, materials, tools, transportation, equipment, services, and facilities required for the complete installation of all work as shown on the plans and outlined in the specifications. The work shall also include all material, equipment, and apparatus not shown, but which are necessary to make a complete working installation of systems. The drawings and specifications are not fabrication drawings or step by step instructions. Their intent is to establish the minimum standard of performance that is acceptable for this project. All the work and every device is not necessarily described or indicated. The contractor is expected to include these items in his bid by his foresight from previous experience or with a dollar contingency amount for unforeseen expenses. The Contractor should be familiar with the architectural, structural, civil, plans etc. before making a bid. If the contractor needs step by step instructions to complete this work or if he is not familiar with the local codes or the type of systems being installed, he is advised not to submit a bid or to work on this project. Field measuring and coordinating with other trades is mandatory. The engineer does not guarantee the accuracy of the dimensions of new or existing work. Coordinate each equipment size with the location where it is to be installed before ordering. Notify engineer if space does not allow for equipment specified. All such dimensions shall be verified by the Contractor and it is his responsibility to fit all new work to existing. All off-sets and small changes in routing are considered a part of the scope of the base bid for this project and shall be accepted by the Engineer or Architect before installation. It is the responsibility of the contractor to work with the city or governing agency and to satisfy their requirements. It will not be the responsibility of the architect or engineer to satisfy these requirements. The work and the material that are a part of this responsibility are to be included in the bid or price by the contractor. Supply and install the following systems in a complete and 100% working order, satisfying all applicable codes:

- A. Sanitary sewage systems, including connections, taps and fees, except as otherwise noted to all fixtures, etc., to existing sanitary. Coordinate with city utility all requirements before ordering equipment or supplies. If included in bid documents refer to Civil drawings and specifications for further information. If there is conflicting information contact Engineer immediately.
- B. Domestic cold water system, meter, taps and fees, and services to all fixtures and outlets including connections to water main. Coordinate with city utility all requirements before ordering equipment or supplies. Refer to Civil drawings and specifications for further information. If there is conflicting information contact Engineer immediately.
- C. Storm Sewer (Storm Drain, Room Drain, Over-flow Drain) systems, including connections, taps and fees, except as otherwise noted to all fixtures, etc., to existing sanitary. Coordinate with city utility all requirements before ordering equipment or

supplies. If included in bid documents refer to Civil drawings and specifications for further information. If there is conflicting information contact Engineer immediately.

- D. Non-potable water supply and return systems and backflow preventors, control valving, insulation, etc. for cistern and wash down systems.
- E. Heating water supply and return systems and backflow preventors, control valving, insulation, etc. for radiant heating system.
- F. Domestic hot water supply and return systems and services to designated fixtures.
- G. Tempered water supply systems and services to designated fixtures.
- H. Irrigation water supply, meter, taps and fees, backflow preventor with RPZ, and stub-out and cap for irrigation system. If included in bid documents refer to Civil drawings and specifications for further information. If there is conflicting information contact Engineer immediately.
- I. Pipe sleeves, forms for chases in concrete, and all supports.
- J. Furnishing and installing of all plumbing fixtures whether designated on plans or not.
- K. All excavation and backfill necessary for installation of all underground utility and plumbing work and all cutting required to complete the work.
- L. Furnishing and installing air conditioning and ventilating equipment with all piping and ductwork.
- M. All roof drains, overflow drains, and storm water piping. Coordinate with city utility all requirements before ordering equipment or supplies.
- N. All condensate drains (whether indicated on drawings or not).
- O. A system of natural gas piping as indicated on the plans from point of connection at utility meter through last appliance. Coordinate with city utility all requirements before ordering equipment or supplies. Refer to Civil drawings and specifications for further information. If there is conflicting information contact Engineer immediately.
- P. Hook up complete of whirlpool baths, dishwashers, ice makers, washers, and any and all equipment furnished by owner and indicated on Architectural, Mechanical, and Plumbing sheets.
- Q. Fire protection, system complete, including yard line from point of connection at water main thru backflow preventor with RPZ, and distribution piping system with kitchen exhaust hoods as required. Coordinate with city utility all requirements before ordering equipment or supplies.

- R. Furnishing and installing air conditioning and ventilating equipment that is 100 % operational with all piping, ductwork, grilles and insulation.
- S. Contractor is to supply all low voltage wiring, install all low voltage wiring (in raceway provided by Div. 26), and make final connections/terminations to the mechanical equipment requiring low voltage whether indicated on the drawings or not. Entire line and low voltage control wiring is to be in conduit and boxes. Low voltage wiring is 50 volts and below. This is to be a complete working and operational system. Contractor is to furnish HVAC programmable controls and control wiring diagrams to project. **ALL CONTROL WIRING FOR MECHANICAL, AND PLUMBING EQUIPMENT IS TO BE IN CONDUIT IN ITS ENTIRITY. (NO EXPOSED WIRING) REFER TO ELECTRICAL SPECIFICATIONS FOR CONDUIT, FITTINGS, AND TYPE TO BE USE SPECIFIC LOCATIONS.**

2.02 WORK TO BE DONE BY CONTRACTOR:

The Contractor will perform the following work in connection with the mechanical contract:

- A. Build into the building construction all pipe sleeves and bolt inserts deemed necessary for hangers, piping, etc. Pipe sleeves and bolt inserts will be furnished and set in place by the Contractor.
- B. Provide chases, shafts, and recesses necessary for the installation of all mechanical equipment, and all furring necessary to conceal piping, etc. The Contractor is required to supply and install all necessary information as to sizes, exact locations of chases, recesses, and furring necessary.
- C. Provide wall, floor and roof openings, including curbs where required, necessary for the installation of the mechanical systems. Contractor shall provide the project with all necessary information as to exact size and location of such openings, and shall be responsible for the completed installations being watertight and weatherproofed.
- D. Install door grilles.
- E. Provide painting as described in the Painting Division of this specification and as noted herein.
- F. Provide bases and supports for principal items of mechanical equipment as shown on the general plans and structural plans, Contractor shall provide the project with all necessary information as to exact size and location of all bases and supports, and shall be responsible for all bases and supports other than those specified above, including house keeping pads.

2.03 BUILDING CODES:

This project is to be installed to satisfy the applicable International Mechanical, Plumbing, Fuel & Gas, Building, Fire Codes and NFPA (I.B.C., I.M.C., I.F.C., I.F.G.C., & I.P.C.) and A.D.A. The American with Disabilities Act. The mechanical contractor for this project is to be one who shall be totally familiar with these codes. The contract documents (plans and

specifications) are not step by step instructions. Their intent is to establish the minimum standard of performance that is acceptable for this project. If any system, device, piping, etc. is not mentioned in the contract documents and is required to meet the Codes and any applicable local city, county or state codes, the Contractor shall install the item per code as part of the base contract with no additional compensation.

2.04 NOTICE TO BIDDERS:

All parties bidding on this work shall be sure that they understand all requirements of the plans, details, these writings and local conditions thoroughly, for each will be bound by all things appearing therein, should the contract be awarded him, and in case of any obscurity or uncertainty, he shall apply to the engineer in writing for a correct interpretation **before** submitting his bid.

- 2.07 The Mechanical and Plumbing Contractor, prior to bidding the project, shall check Architectural, Civil, Structural, Plumbing, Electrical, Heating and Ventilating plans and specifications to avert possible installation conflicts. Discrepancies shown on different plans and specifications, or other necessary changes shall be brought to the attention of the Architect, Contract Administrator or Engineer for a decision to resolve the conflicts. Failure to coordinated and notify prior to bidding shall be at the contractors expense and there will be no additional cost to the owner or to the project.

PART 3 - FIELD REPORT OBSERVATIONS

3.01 SITE VISITS

- A. Entire underground is installed and not buried.
- B. Rough-ins before sheet-rocked or cinder blocked, i.e. concealed.
- C. Above ceiling, before ceiling is installed
- D. Final walk thru, when contractors are finished with installation
- E. Final punch, check any items of the final walk thru.

3.02 OBSERVATION FORM LETTER

The next site visit will not take place until the following form, refer to paragraph 3.03, is filled out stating that the item was fixed, a reason why it can not be accomplished or alternative solution that has been signed by the contractor that made the correction or comment.

SECTION 26 05 11 GENERAL ELECTRICAL

PART 1

1.01 GENERAL:

The General Conditions of specifications and all preceding sections bound herewith are included in and made a part of these sections.

1.02 NOTICE TO BIDDERS:

All parties bidding on this work shall be sure that they understand all requirements of the plans, details, these writings and local conditions thoroughly, for each will be bound by all things appearing therein, should the contract be awarded him, and in case of any conflict, discrepancy, obscurity or uncertainty, he shall apply to the engineer in writing for a correct interpretation before submitting his bid.

1.03 MATERIAL SUBMITTALS:

- A. Unless deemed otherwise by the engineer, no single items will receive consideration. Only bound complete submittals will receive consideration. This submittal shall be made within 30 days after awarding of the contract.
- B. Submit six (6) copies, bound in six (6) Green Three-ring binders, to the architect for approval. Submittals to have a table of contents and index tabs for easy reference and usability. Submittals should be clearly marked in red to show any changes from the original specifications. In case of re-submittal, the contractor shall re-submit in quadruplicate showing required corrections and shall continue to re-submit until approval is obtained.
- C. All specified equipment and material shall be submitted to include associated items required for complete installation.
- D. Acceptance, corrections or comments made on submittals and/or shop drawings during review do not relieve the contractor/supplier from compliance with the specifications. This check is only for review of general conformity with the design concept of the project and general compliance with the information given in the contract documents. The sub-contractor or supplier is responsible for confirming and correlating all quantities and dimensions; selecting fabrication processes and techniques of construction and coordinating his work with that of all other trades (unless specifically stated otherwise in the contract documents).

1.04 COOPERATION:

- A. This Contractor shall promptly report to the General Contractor any conditions which might prevent prompt and proper installation of work, or make it unsuitable to connect with or receive work of others. Failure to so report shall constitute acceptance of the work as being fit and proper for completion of this work.
- B. In general, the following priorities shall prevail:
 - 1. Ductwork
 - 2. Building Drainage
 - 3. Piping
 - 4. Electrical

1.05 MATERIAL OTHER THAN THOSE SPECIFIED:

- A. The base bid and alternate shall include all items as they are specified or detailed in the drawings or approved equals.
- B. Where several manufacturers are listed for one use, the contractor may select any of those specified.
- C. A request for consideration of items other than those specified, which are to meet or exceed the plans and specification, may be made to the engineer in writing until ten (10) days before bid date. An Addendum will then be issued listing any materials which may have been accepted. There will be no subsequent substitutions.
- D. In those cases where an equal product is allowed, the decision as to quality rest with the engineer.

1.06 CLEANING:

- A. All lighting fixtures, lenses, and panels, shall be cleaned of all dirt, scratches, etc.
- B. All Electrical Equipment, Panel & Switchboards, Disconnects, Transformers, Starters, Contactor Enclosures etc.

1.07 EXCAVATION AND BACKFILLING FOR PIPING:

- A. The Contractor shall do all excavating, backfilling, shoring, bailing and pumping for the installation of his work. Sewer lines shall not be used for draining trenches and the end of all pipe and conduit shall be kept sealed and lines left clean and unobstructed during construction. Only material suitable for backfilling shall be piled a sufficient distance from banks of trenches to avoid overloading.

Unsuitable backfill material shall be removed as directed by engineer. Perform grading necessary to prevent surface water from flowing into trenches or other excavations.

Sheathing and shoring shall be done as necessary for protection of work and safety of personnel. Unless otherwise indicated, excavation shall be by open cut except that for short sections.

A trench may be tunneled if in the opinion of the architect, the pipe or duct can be properly installed and backfill can be properly tamped. Two feet minimum cover shall be used for electrical conduit. All pipe shall be laid on a graded 4 inch bed of sand.

- B. After testing and approval of the pipe lines, trenches shall be backfilled to a depth of 6 inches over the top of pipe with washed river sand. Balance of fill material shall contain no rock, wood or other organic materials, and shall be placed in layers not over 6 inches thick and each layer thoroughly compacted so no later settlement will take place. Backfill shall be brought up to level of ground surface and surface graded to satisfaction of engineer. When under buildings, structures, walks and concrete slabs the entire ditch is to be filled with sand to grade.
- C. The Contractor shall install six inches below grade and directly above all domestic water, irrigation supply water, fire protection, sanitary sewer, storm sewer, electrical conduits and natural gas lines with an mylar foil back warning tape and #12 tracer wire on pipe. Tape shall be aluminum foil encased in two layers of inert plastic film enabling the tape to be inductively located. Terra Tape "D" Warning Tapes are acceptable. Tape shall bear a continuous imprinted message repeated every 16 to 36 inches warning of the installation buried below. The message shall read "CAUTION" and then name the utility buried below. Example: "CAUTION (ELECTRICAL,

PHONE, CABLE TV, ETC) LINE BURIED BELOW". Installation instructions for the tape shall be printed with each message along the entire length. The tape shall be as that manufactured by Reef Industries, Inc., Houston, Texas (Terra Tape) or an approved equal. Tape shall have metallic content and shall respond to metal detectors. **Do not exclude this.** It will be required to verify the installation of this tape.

- D. Protection of Existing Utilities - Existing utility lines uncovered during excavation operations, shall be protected from damage during excavation and backfilling, or if damaged shall be repaired by Contractor.

1.08 START-UP AND SERVICE:

- A. Place all equipment and systems in trial operation and adjust all components for proper operation and balance.
- B. On date of final inspection, provide services of qualified personnel to operate equipment. Remove and replace access panels, make equipment adjustments and generally assist the engineer inspector in the complete examination of the work.
- C. Free service for seasonal start-up and adjusting of heating and cooling equipment shall extend through the next seasonal start-up following acceptance by the owner. If system is operating on "summer cycle" at acceptance, the Contractor shall provide winter start-up service and free service for adjustments.

1.09 OPERATING INSTRUCTIONS:

- A. Provide operating folio, in duplicate, containing the following:
1. Brief typewritten statement of start-up and shut-down sequence for each item of equipment and each system. Statement should refer to valves, switches and starters by both name and assigned number.
 2. Typewritten or printed installation, operation and maintenance instructions for each item of equipment. This shall include points of lubrication, recommended lubrication frequency, type of lubricant, normal adjustment procedures and troubleshooting procedures.

This section shall further include name and model number of each item of equipment, the source of repair parts and services and manufacturers' repair lists.
 3. Folio shall be bound and submitted to architect for approval and transmission to owner.
- B. All switches, starters, etc. shall be tagged with brass tags or etched plastic labels, black letters on white background, and they shall be identified as in the above instructions.
- C. One copy of shop drawings covering the control diagram and sequencing "As Built" shall be framed behind glass and mounted where indicated in the equipment room.

1.10 AS BUILT DRAWINGS:

- A. Deliver to architect upon completion of work two (2) complete sets of contract drawings (white prints) marked up to show all deviations from indicated installations. Markings shall include:
1. Changes in routings of concealed piping.
 2. Changes in electrical circuitry and home runs.
 3. Other changes to concealed work which affect future maintenance and repair operations.

1.11 GUARANTEE:

The Contractor shall guarantee all work, materials and equipment under these specifications for a period of one (1) year from the date of formal acceptance. Within the guarantee period, all defective equipment of installation shall be made operative to the satisfaction of the Owner without additional cost to the Owner.

PART 2

2.01 GENERAL CONDITIONS:

- A. The General Conditions bound herewith are included and made a part of this specification and contract. All of the conditions mentioned here-in shall apply except as otherwise amplified or altered in the following specifications. Particular reference is made to the paragraph pertaining to material substitution.
- B. The drawings which constitute an integral part of this contract shall serve as the working drawings. They indicate the general layout of the complete electrical system, arrangement of feeders, circuits, outlets, switches, controls, panels, service equipment, fixtures and other work. Data presented in these drawings are as accurate as preliminary surveys and planning can determine, but accuracy is not guaranteed. Field verifications of scale dimensions on plans are the responsibility of the Contractor since final locations, distances and heights will be governed by actual field conditions. Schedules of panelboards, branch circuits, motors and other equipment showing quantities, sizes, special features or auxiliary devices are for the convenience of the Contractor. Any item not specifically mentioned but is obviously necessary to make a complete working installation, or omitted from a schedule, but shown on the drawings, or omitted from the drawings, but shown in the schedule shall be furnished and installed at no extra cost to the Owner. It shall be the responsibility of the Contractor to check all MEP schedules with the drawings in order to verify all quantities and special requirements before ordering equipment.
- C. The Electrical Contractor, prior to bidding the project, shall check architectural, civil, structural, plumbing, heating and ventilating plans, schedules and specifications to avert possible installation conflicts. Prior to projects bid date, discrepancies shown on different plans and specifications, or other necessary changes shall be brought to the attention of the Architect, Contract Administrator or Engineer for a decision to resolve the conflicts.

2.02 ELECTRICAL WORK INCLUDED:

- A. The work under this contract shall include the furnishing, delivery, installation, testing and placing in

operation of all equipment, materials and devices required to provide a complete electrical installation as shown on the accompanying drawings and/or set forth in these specifications.

B. Deliver to Owner upon completion, ready for use in all respects, the following complete electrical systems and equipment:

1. Ditching, raceway and backfilling for underground primary service.
2. A concrete pad and grounding system for Utility Company's pad mounted transformer.
3. Underground secondary service to building from pad mounted transformer.
4. Underground conduit, ditching, and backfill to building from site lights, CATV, Telephone service point and all underground as shown on plans.
5. All secondary switch gear, main switchboard, power panel-boards, lighting panelboards, etc.
6. All disconnecting switches complete with fuses.
7. Complete system of feeders, sub-feeders, and branch circuit conduit system.
8. Furnish, install and connect all lighting fixtures, complete with lamps.
9. Furnish and install all wiring devices, time switches, contactors and transformers.
10. Furnish and install telephone service, cabling and outlets.
11. Furnish and install Network Cabling and outlets.
12. An emergency exit lighting system.
13. An intercommunication system.
14. Furnish and install CATV Cabling and outlets.
15. Provide a Security Alarm System & all associated devices.
16. Furnish and install complete fire alarm system and devices with conduit to accessible ceiling space. Interface with security system. Design system and provide all devices required by National, International, State and Local codes for a complete and functional Fire Alarm Detection System.
17. A complete line and low voltage raceway system, and line voltage wiring as required for mechanical equipment and controls.
18. Complete functional grounding system per Grounding Sections of Specifications, as shown on plans sheets and per NEC and local code.
19. Power to all equipment provided by others/owner. Coordination of which is the responsibility of this contractor.
20. Power, raceway and wire/control wire to all dampers (motorized, fire..etc..) in conduit, per plans, and Div. 15 Mechanical Contractor requirements.
21. Furnish and install as required (5) additional exit lights. Contractor is to receive instruction at project completion for exact locations.
22. Furnish and install as required (5) additional F/A smoke detectors. Contractor is to receive instruction at project completion for exact locations.

2.03 WORK AND MATERIALS BY OTHERS:

The following work and materials will be furnished by others and is not a part of these specifications.

- A. General Contractor - Required painting and furring; concrete curbs and pads, roof openings and flashings.
- B. Mechanical Contractor - Mechanical equipment factory prewired controllers and starters, mechanical equipment motors, furnishing of all temperature controls, complete mechanical equipment and wiring and control diagrams.

2.04 SERVICE ENTRANCE:

- A. Electric distribution system for building will be available from a pad mounted transformer at 208/120 Volts, 3 Phase, 4 Wire, 60 Cycle with grounded neutral.
- B. Utility Company will furnish and install the primary service conductors and pad mounted service transformer.
- C. This Contractor to furnish primary service ditching, raceway and backfill, concrete transformer pad, grounding system for transformer pad (all per utility company requirements) and the secondary service to building as detailed on plans. Provide metering conduit as required or as shown on plans.

PART 3 - EXECUTION

3.01 BUILDING CODES:

This project is to be installed to satisfy the most current National Electrical Code (NFPA 70). The electrical contractor for this project is to be one who shall be totally familiar with these codes. The contract documents (plans and specifications) are not step by step instructions. Their intent is to establish the minimum standard of performance that is acceptable for this project. If any system or device, etc. is not mentioned in the contract documents and is required to meet the N.E.C. the Contractor shall install the item per code as part of the base contract with no additional compensation.

3.02 TEMPORARY WIRING, LIGHTING, AND POWER:

- A. The Contractor shall make all arrangements with the Owner for temporary electrical service to the construction site, and shall provide all equipment necessary for temporary power and lighting, and pay all charges for this equipment and installation thereof. The electrical service shall be of required voltage and adequate capacity for all construction tools and equipment without overloading the temporary facilities and shall be made available without charge for power, lighting and construction operations of all sub-contractors.
- B. Provide power distribution as required throughout this project of 208V, 3 Phase, 4 Wire, 60 Hertz. The termination of power distribution shall be at convenient locations in each building, as directed. Terminations shall be provided for each voltage supply and complete with circuit breakers, fused disconnect switches and other electrical devices as required to protect the power supply system.
- C. A temporary lighting system shall be furnished, installed, and maintained as required to satisfy minimum requirements of safety and security at all times when work is being performed by all of the various trades.

3.03 LABELING AND IDENTIFICATION:

All electrical equipment and devices shall be clearly labeled and identified.

- A. Panelboards/Swtichboards & Transformers with plastic etched nameplates, black letters on white background.
- B. Motor starters, disconnect switches, time switches, junction boxes (whether exposed or concealed) bussway or any plug remotely located from equipment served shall be labeled with plastic etched nameplates, black letters on white background.

C. All equipment served with over 240V shall have a stenciled sign painted on enclosures stating "DANGER HIGH VOLTAGE".

D. All junction boxes to be marked on cover with magic marker all circuit numbers utilizing this box.

3.04 Not Used

3.05 LOAD BALANCING AND READINGS:

The Electrical Contractor shall furnish the Engineer at the completion of the work an itemized list of all feeder and main service loadings including voltages and ampere readings. These readings shall be taken with building under full load. Readings shall substantiate correct voltage and balanced loads.

3.06 TESTING:

All wire and cable shall be tested after installations are completed. The test results shall meet the minimum requirements as listed in the NEC. The Engineer shall be advised when tests are scheduled to permit witnessing by the Owner and/or Engineer.

3.07 EXISTING CONDITIONS:

The existing construction has been referenced to from on-the-job observations. If during construction radically different conditions are found, the Contractor shall so notify the Architect or Engineer and on-the-job corrections shall be made. Verify all site grades before beginning excavation to assure proper covering of new piping.

3.08 TELEPHONE SYSTEM:

A. This Contractor shall furnish and install an telephone service conduit & all cabling for telephones as shown on the drawings. Furnish and install underground service conduit to telephone equipment in building from property line. Extend conduit to all outlets from this location or stub outlets into ceiling spaces whichever is indicated on plans. All conduit is to be ¾" with a plastic bushing.

B. Furnish terminal at service entrance with 4' X 8' X 3/4" fire rated plywood backboard on the wall as indicated on plans. Conduits shall terminate at the top and bottom edge of the board with plastic bushings.

C. The Telephone Company will furnish and install all equipment and wiring to the building telephone terminal board. The installation of all equipment shall meet their requirements.

D. Paragraphs covering Conduit, Boxes, etc., above are applicable.

E. All telephone plates shall match receptacle / switch plate color / material.

F. Install two pair telephone cable from each telephone outlet to telephone terminal board. Any cable installed in an air return ceiling shall be approved for the application.

G. Install #6 AWG minimum grounding conductor tied to service ground, and provide ground bar per Utility requirements.

- H. Provide and install a blank plate for all unused telephone / communications outlets

3.09 SCOPE:

Furnish all labor, materials, tools, transportation, equipment, services, and facilities required for the complete installation of all work as shown on the plans and outlined in the specifications. The work shall also include all material, equipment, and apparatus not shown, but which are necessary to make a complete working installation of systems. The drawings and specifications are not fabrication drawings or step by step instructions. Their intent is to establish the minimum standard of performance that is acceptable for this project. All the work and every device is not necessarily described or indicated. The contractor is expected to include these items in his bid by his foresight or with a dollar contingency amount for unforeseen expenses. The Contractor should be familiar with the architectural, structural, civil, plans etc. before making a bid. If the contractor needs step by step instructions to complete this work or if he is not familiar with the local codes or the type of systems being installed, he is advised not to submit a bid or to work on this project. Field measuring and coordinating with other trades is mandatory. The engineer does not guarantee the accuracy of the dimensions of new or existing work. Coordinate each equipment size with the location where it is to be installed before ordering. Notify engineer if space does not allow for equipment specified. All such dimensions shall be verified by the Contractor and it is his responsibility to fit all new work to existing. All off-sets and small changes in routing are considered a part of the scope of the base bid for this project and shall be approved by the Engineer or Architect before installation. It is the responsibility of the contractor to work with the city or governing agency and to satisfy their requirements. It will not be the responsibility of the architect or engineer to satisfy these requirements. The work and the material that are a part of this responsibility are to be included in the bid or price by the contractor.

PART 4 - FIELD REPORT OBSERVATIONS

4.01 SITE VISITS

- A. Entire underground is installed and not buried.
- B. Rough-ins before sheet-rocked or cinder blocked, i.e. concealed.
- C. Above ceiling, before ceiling is installed
- D. Final walk thru, when contractors are finished with installation
- E. Final punch, check any items of the final walk thru.

4.02 OBSERVATION FORM LETTER

The next site visit will not take place until the following form, refer to paragraph 4.03, is filled out stating that the item was fixed, a reason why it can not be accomplished or alternative solution that has been signed by the contractor that made the correction or comment.